

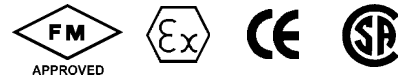

Intrinsically Safe Pressure Transmitters
Type 892.13.500 - Vacuum to 300 PSI
Type 892.23.510 - 400 PSI to 15,000 PSI

Tronic

- FM and Ex approved for Class I Division I locations when used with an approved barrier
- 4-20 mA 2-wire output signal
- Highly resistant to pressure spikes and vibration
- Stainless steel case and wetted parts
- Can be assembled to chemical seals



Intrinsically safe pressure transmitters are engineered for applications requiring class I, Division I protection in hazardous environments. Each unit undergoes extensive quality control testing and calibration to achieve an accuracy $\leq 0.25\%$ full scale. The printed circuit boards use state-of-the-art surface mount technology and are potted in epoxy casting resin for protection against mechanical shock, vibration, and moisture. Each unit is temperature compensated to assure accuracy and long term stability when exposed to severe ambient temperature variations.

The compact design provides an economical, rugged transmitter suitable for many applications in hydraulics and pneumatics, vacuum, test equipment, liquid level measurement, press control, compressor control, pump protection and numerous other processing and control operations.

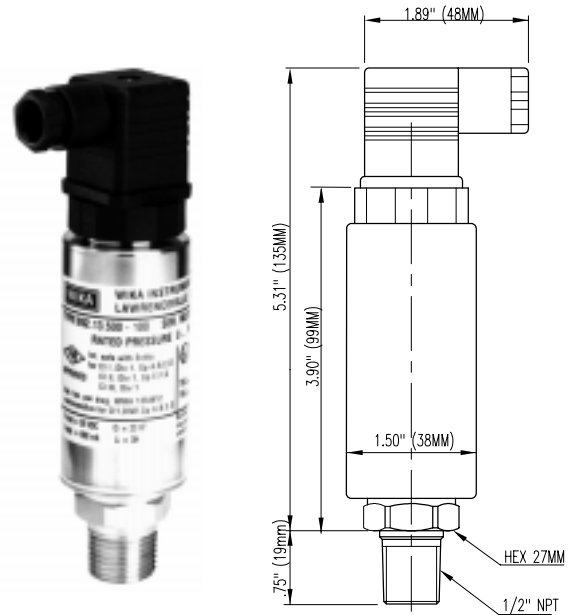

STANDARD RANGES

RANGE	MAXIMUM*	BURST**	RANGE	MAXIMUM*	BURST**
Type 892.13.500			Type 892.23.510		
30"-0 HgVac	70 PSI	70 PSI	0-400 PSI	1100 PSI	3600 PSI
30"-0-30 PSI	250 PSI	250 PSI	0-500 PSI(A)	1100 PSI	5800 PSI
30"-0-60 PSI	500 PSI	500 PSI	0-600 PSI	1100 PSI	5800 PSI
30"-0-100 PSI	500 PSI	500 PSI	0-750 PSI	1100 PSI	5800 PSI
30"-0-160 PSI	500 PSI	500 PSI	0-1000 PSI	1750 PSI	8000 PSI
30"-0-200 PSI	1100 PSI	1100 PSI	0-1500 PSI	2900 PSI	11,600 PSI
0-50 INWC	30 PSI	30 PSI	0-2000 PSI	4600 PSI	14,500 PSI
0-100 INWC	30 PSI	30 PSI	0-3000 PSI	4600 PSI	14,500 PSI
0-5 PSI	30 PSI	30 PSI	0-5000 PSI	11,600 PSI	25,000 PSI
0-10 PSI	60 PSI	60 PSI	0-8000 PSI	17,400 PSI	35,000 PSI
0-15 PSI(A)	70 PSI	70 PSI	0-10,000 PSI	17,400 PSI	35,000 PSI
0-25 PSI(A)	145 PSI	145 PSI	0-15,000 PSI	21,750 PSI	43,500 PSI
0-30 PSI	145 PSI	145 PSI			
0-50 PSI(A)	250 PSI	250 PSI			
0-60 PSI	250 PSI	250 PSI			
0-100 PSI(A)	500 PSI	500 PSI			
0-160 PSI	500 PSI	500 PSI			
0-200 PSI	500 PSI	500 PSI			
0-250 PSI(A)	1100 PSI	1100 PSI			
0-300 PSI	1100 PSI	1100 PSI			

Notes:
 * Maximum pressure, causing no permanent changes in specifications but may lead to adjustable zero and span shifts.
 ** Burst pressure, leading to destruction of the transmitter and possible loss of media.
 (A) Standard ranges available with absolute pressure reference.

Specifications

Input

10-28 VDC

Output & load limitations

4-20mA 2-wire $R_{(max)} = (V_s - 10V) / 0.02 A$

Accuracy

Linearity (B.F.S.L.): $\leq 0.25\%$ of span {0.125%}¹

Hysteresis: $\leq 0.1\%$ of span

Repeatability: $\leq 0.05\%$ of span

1 yr. stability: $\leq 0.2\%$ of span

Response time: ≤ 1 ms

(10-90% full scale)

Zero & span adjustments: approx +/- 10.0% full scale

Temperature

Effective temperature compensation

+32 °F to 176 °F

Media -22 °F to 212 °F

Ambient -4 °F to 176 °F

Storage -40 °F to 212 °F

Temperature error (reference temperature 70 °F)

On zero (% of span/18 °F) ≤ 0.2

On span (% of span/18 °F) ≤ 0.2

Process connection

1/2" NPTM {other connections available}

Electrical connection

DIN 43650 solderless screw terminal with 1/2" female conduit (IP 65 / NEMA 5)

Material

Wetted parts 316 stainless steel

Body material 304 stainless steel

Transmitting liquid

Silicone oil to 300 PSI, none in ranges ≥ 400 PSI {Fluorocarbon oil for oxygen service}

Electrical protection

Protected against reverse polarity

Vibration protection

Internal electronics 100% potted in epoxy casting resin

CE Conformity

Interference emissions per EN 50 081-1 and -2

Interference immunity per EN 50 082-2

Notes: Items in curved brackets { } are available on special order.

¹Improved accuracy available with pressure ranges ≥ 100 NWC

Conformity specifications

	E Ex ia II C T5	E Ex ia II C T6	NOTE: Power supply may be by means of common zener barriers or equivalent certified devices if the transmitters are operated within above temperature limits. The temperatures in parentheses are applicable if the output of the power supply is limited to the power rating values given in parentheses.
Power supply	10...28 VDC	10...28 VDC	
Short circuit Rating	660mA	660mA	
Power Rating	(1.75W)	(1.75W)	
Operating Temperature	-5°/150 °F (-5°/165 °F)	-5°/120 °F (-5°/140 °F)	

THE MEASURE OF Total Performance™

Wiring

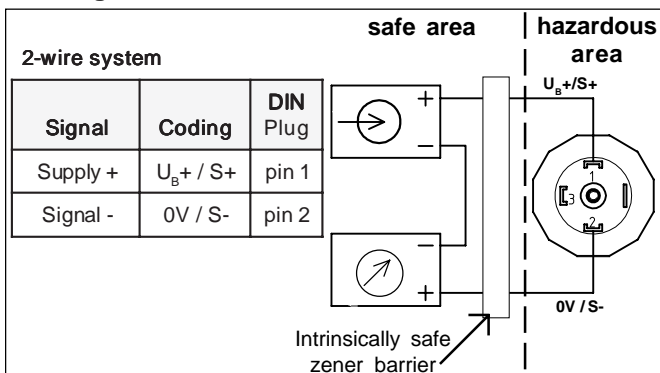

Calibration

All WIKA transmitters are calibrated at the factory. In the event calibration is required as a maintenance procedure, please use the following steps:

1. Remove cap
2. Set zero pot
3. Test zero
4. Set span pot
5. Test span
6. Replace cap

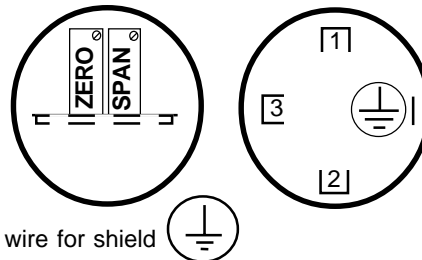

Use pin 4 or blue wire for shield

Approval authority

CENELEC/BASEEFA/BVS (European)

FACTORY MUTUAL intrinsically safe with entity approval for:

Class I, Division 1, Groups A, B, C, D

Class II, Division 1, Groups E, F, G

Class III, Division 1

hazardous location per WIKA dwg. 1354612

nonincendive for Class I, Div 2, Groups A, B, C, D

$V_{max} = 28 V$

$C_i = 20 nF$

$I_{max} = 660 mA$

$L_i = 0 uH$

Codes compliance

EN 50014/50020 relating to intrinsically safe products

FM-3610 intrinsic standard

Ordering Information:

State computer part number (if available) / type number / size / range / connection size and location / options required.

Specifications given in this price list represent the state of engineering at the time of printing. Modifications may take place and the specified materials may change without prior notice



WIKAL Instrument Corporation

1000 Wiegand Boulevard

Lawrenceville, Georgia 30043-5868

Tel: 770-513-8200 Fax: 770-338-5118

http://www.wika.com e-mail: info@wika.com