



Model 365A
Vibraswitch®
Malfunction Detector



General Description

The Model 365A **VIBRASWITCH** provides maximum protection for large motors, pumps, compressors, and other rotating equipment by responding to mechanical malfunctions the instant they occur. Failing bearings, bent shafts, broken blades, overspeeding and similar malfunctions cause increased imbalance or high frequency vibration detectable with the Model 365A **VIBRASWITCH**. The instrument may be wired to actuate an alarm or cause a shutdown before costly damage occurs. It is designed for maintenance-free service in permanent installations.

The **VIBRASWITCH** is an acceleration sensitive instrument that measures the total acceleratory shock present on the machine. Acceleration is a vibration characteristic of prime importance in cases of mechanical failure on reciprocating or rotating machinery. Newton's second law of motion states that the force exerted on a body is equal to its **mass** multiplied by its **acceleration: $F = MA$** . Thus the destructive forces acting on a bearing are directly dependent on the acceleration of the masses involved at the shaft that is supported by the bearings.

Acceleratory measurements made by the **VIBRASWITCH** is the summation of all the individual accelerations giving a total destructive force acting on the machine - the result is positive protection.

With the growing use of computers, an increasing number of applications are coming into existence where a **VIBRASWITCH** will be connected to a computer or PLC. In these applications the voltage and/or current may be too low for standard contacts. For these applications the Model 365A may be supplied with an optional sealed switch with gold contacts.



Features and Benefits:

- **Explosion Proof**
UL & c-UL Certified
- **Weather Proof**
Type 4 & IP66 (all models)
Type 4X (optional)
- **Self Powered**
Does not require external power to operate
(Except for remote reset)
- **Optional Gold Contacts**
For low voltage/current applications
- **Acceleration Sensitive**
Measures destructive forces
- **Minimum Maintenance**
No moving parts except at trip level
- **Continuous Protection**
No attention required after installation
- **Ease of Installation**
Requires no special training
- **Long Life**
Instrument is rugged and durable – no wear
- **Ease of Adjustment**
Set it and forget it – one adjustment
- **Reset**
Remote electrical or manual at unit
Either AC or DC voltages available

Principle of Operation

The Model 365A **VIBRASWITCH** employs a magnetic circuit opposed by inertial and adjustable spring forces in the actuating mechanism. Operation of the **VIBRASWITCH** may be understood by reference to Figure 1. The armature is constrained so as to respond to only one direction of movement by a frictionless flexure pivot composed of two overlapping blocks and a leaf spring loaded in one direction to hold the blocks together. The armature rotates on the pivot being forced in one direction by the adjusting spring force and the other direction by the magnetic force.

When the entire assembly is subjected to vibration perpendicular to the base, the peak acceleration times the effective mass of the armature produces an inertial force, aided by the adjustable spring tending to pull the armature away from the stop pin and the restraining force of the magnet. When the peak acceleration exceeds the set point level the armature leaves the stop pin, increasing the gap and decreasing the force with the armature continuing to move up until it reaches the latch magnet, actuating the switch during its upward travel.

The **VIBRASWITCH** may be reset by depressing the reset button or by applying power to the electrical reset coil. The effect of temperature in the mechanism is negligible as the elastic modulus of the adjusting spring and the magnetic flux through the air gap both decrease slightly with increasing temperature thereby compensating each other.

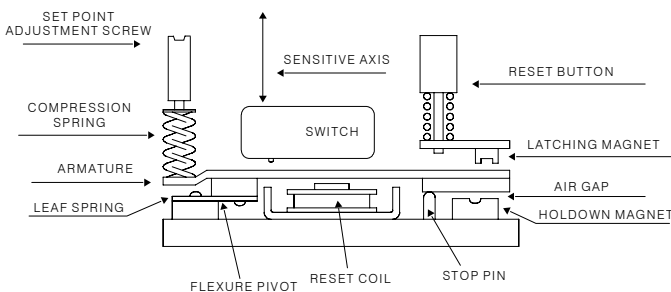

FIGURE 1

Specifications

Enclosure Aluminum, unpainted (standard)
Aluminum, epoxy painted (optional)

Enclosure seals Silicone

Enclosure Hardware Stainless steel

Enclosure Rating:

Class I, Div. 1, Group B, C & D;

Class II, Div. 1, Group E, F & G;

Enclosure 4 or 4X;

Class I, Zone 1, AEx d IIB+H T6;

Ex d IIB+H T6; IP66

Contact Arrangement SPDT or DPDT

Contact Rating:

Designation "A":

SPDT

7 A max, 460 VAC max, 50/60 Hz, NI;

0.5 A max, 120 VDC max, NI;

1 A max, 48 VDC max, NI;

2 A max, 24 VDC max, NI;

5 A max, 12 VDC max, NI

Designation "D":

DPDT

5 A max, 240 VAC max, 50/60 Hz, NI;

5 A max, 30 VDC max, NI

Designation "G":

DPDT – Sealed switch, gold contacts

0.1 A max, 125-250 VAC, NI;

0.1 A max, 30 VDC, NI;

5 mA min at 6 VDC, NI;

2 mA min at 12 VDC, NI;

1 mA min at 24 VDC, NI

Set Point Range:

Mounted Horizontal 0 to 4.5 G (peak)

Mounted Vertical 0 to 3.5 G (peak)

Frequency Range 0 to 300 Hz

Set Point Adjustment 1 G per turn (approximate)

Temperature limit -13° to +140° F (-25° to +60° C)

Shock 40 G @ 11 ms maximum

Manual Reset All models supplied with manual reset

Reset Coil Voltages & Power:

24 VDC ± 10%, 0.5 amp

48 VDC ± 10%, 0.2 amp

120 VDC ± 10%, 0.14 amp

120 VAC ± 10%, 50/60 Hz, 0.3 amp

240 VAC ± 10%, 50/60 Hz, 0.3 amp

Reset Coil Duty Cycle 4 minutes **ON** max.

10 minutes **OFF** min.

Space Heater 2 watt, same voltage as reset coil

Net weight 7 lbs (3.2 kg)

Shipping weight 8 lbs (3.6 kg)

Agency Certification:

UL File No. E164999

c-UL File No. E164999

Notes:

1. Vibraswitches with 240 VAC reset coil are not agency certified.
2. Space heaters are intended to prevent condensation in the enclosure caused by climate conditions in some outdoor installations. Space heaters require constant power and are not required in most applications.
3. Reset coils may be used with external time delays for preventing false trips on those machines with excessive start-up vibration by applying the rated voltage during machine start-up (for 4 minutes maximum).
Reset coils may also be used to reset the Vibraswitch from a remote location by applying the rated voltage.

Switch Configurations

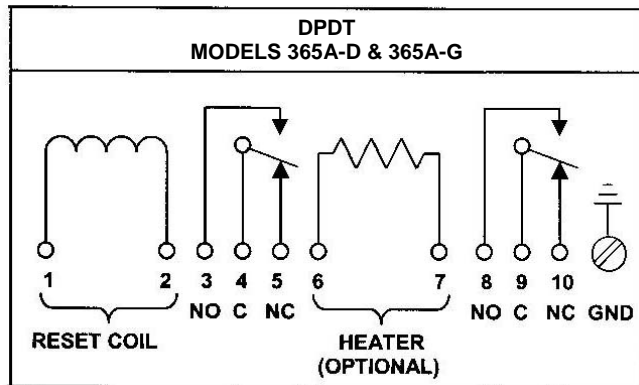
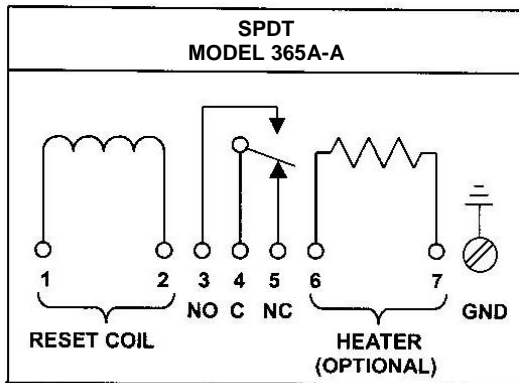

Ordering Information

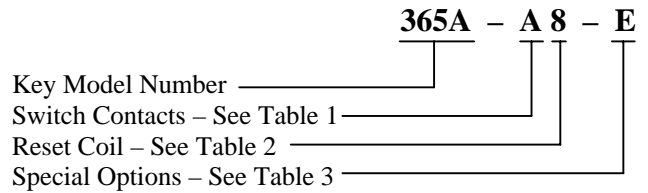

Key Model Number

Designation	Description
365A*	Vibraswitch, UL Certified for the U.S.A. & c-UL Certified for Canada.

* See note 1.

Table 1 – Switch Contacts

Designation	Description
A	SPDT – Single pole, double throw load contacts.
D	DPDT – 2 gang mounted SPDT load switches.
G	DPDT – 2 gang mounted SPDT sealed switches with gold contacts for low voltage/current applications.

Table 2 – Reset Coil (See note 3)

Designation	Description
0	No reset coil
2	24 volt DC reset coil
3*	240 volt AC reset coil.
4	48 volt DC reset coil
7	120 volt DC reset coil
8	120 volt AC reset coil

* Not Agency Certified.

Table 3 – Special Options

Designation	Description
Omit	No special options. Enclosure 4 & IP66, unpainted aluminum.
E	Enclosure 4X & IP66, exterior painted with gray epoxy enamel.
H*	Space heater installed for maintaining internal area of enclosure moisture free.
EH*	Enclosure 4X & IP66, exterior painted with gray epoxy enamel, and space heater installed for maintaining internal area of enclosure moisture free.

* See note 2.

Dimensions

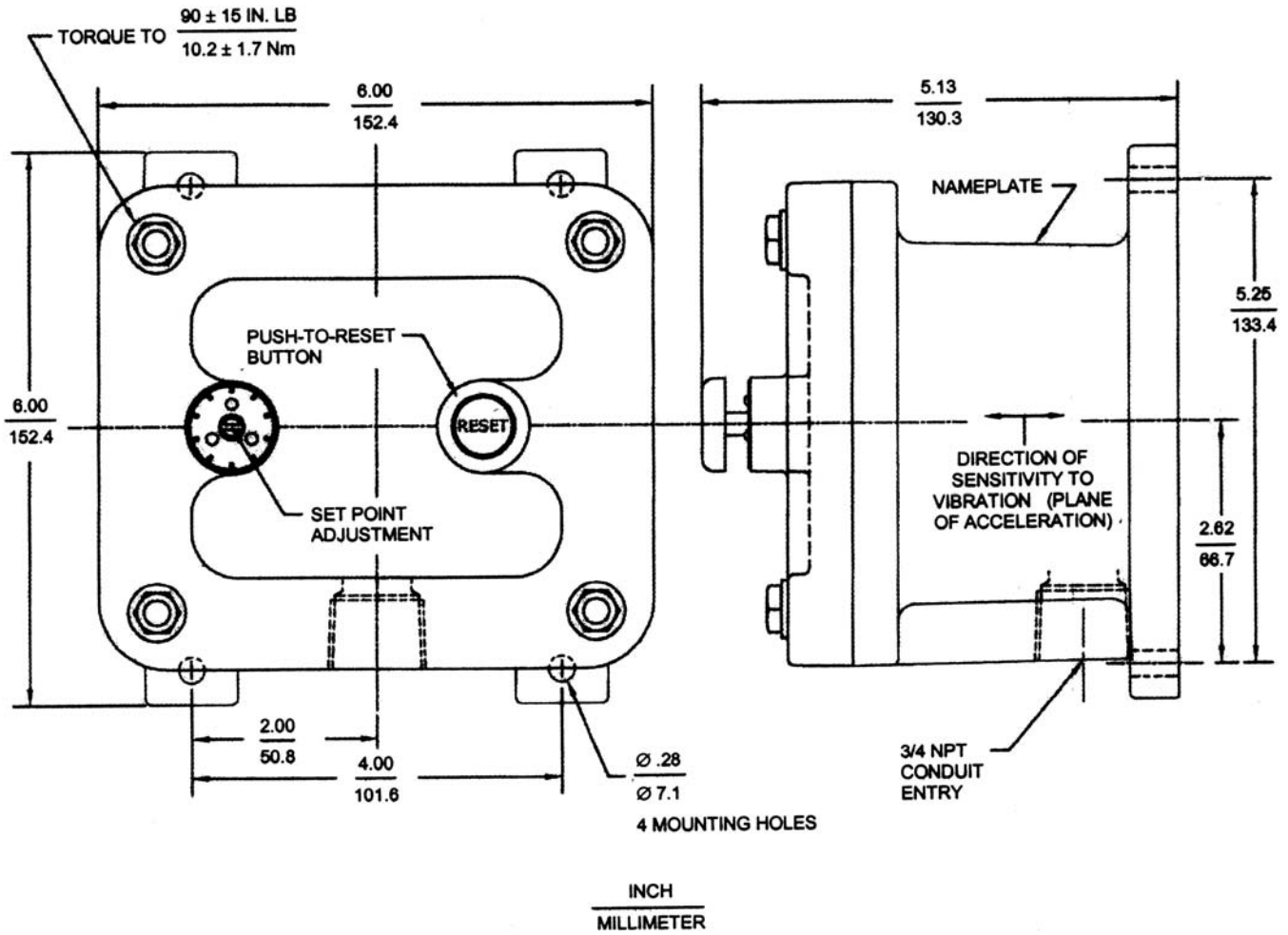

Vibraswitch shown mounted vertical



U.S.A. & Canada

Robertshaw Industrial Products
1602 Mustang Drive
Maryville, Tennessee 37801
Phone: (865) 981-3100 Fax: (865) 981-3168
<http://www.robertshawindustrial.com>

Exports

Invensys Appliance Controls
1701 Byrd Avenue
P.O. Box 26544
Richmond, Virginia 23261-6544
Phone: (804) 756-6500 Fax: (804) 756-6561

Invensys

Q-4176 (10/05)

Printed in U.S.A.