

# Robertshaw

## INDUSTRIAL PRODUCTS DIVISION

Sales Manual Section 60  
PRODUCT SPECIFICATION MODEL DT-700

## FulTrol<sup>®</sup> Pilot Temperature Controller DT-700 Series

### GENERAL DESCRIPTION

Robertshaw's DT-700 Series Pilot Temperature Controllers provide accurate, dependable temperature control when used with various final control elements such as valves, switches, dampers, air motors, etc. in pneumatic control systems. Such systems, depending on relative action of pilot and final control element, may control either heating or cooling or both heating and cooling, and may be arranged so that valves will either open or close on loss of pilot supply pressure.

### SPECIFICATIONS

**Control Action** ..... Direct (Output pressure increases with increase in temperature at sensing element) or Reverse. Control action field reversible.

**Temperature Ranges** ... DT-700-A1, A2 – Any 200 F. range between -50 F. and +350 F. (-50 to +150 F.; +50 to 250 F.; and 150 to 350 F. available from stock.

**Temperature Adjustment** ..... Knob and dial. Dial graduated in degrees F. over 200 F. spans. Equivalent degrees C. graduations available on order.

**Over-run Temperature Protection** ..... Protected to 700 F.

**Proportional Band Adjustment** ..... 5°F. (2-1/2 psi/° F.) to 25°F. (1/2 psi/°F.)

**Pilot Supply** ..... Air, gas, low viscosity oils.\*  
(When ambient temperature is sub-freezing, very dry air must be used.)

\*(CAUTION: Oil can be used only when controlled temperature is between 40 and 180 F.)

**Pilot Supply Pressure** ..... 18 to 20 psi normal; 40 psi max.

**Pilot Consumption** ..... Air - 12 SCFH maximum.

**Output (Control) Pressure** ..... 3-15 psi std.; 5-25 psi, 6-30 psi or 8-40 psi available by increasing pilot supply pressure to 30, 35 and 40 psi respectively.

**Bulb Pressure Limitation** ..... 300 psi @ 300 F., 200 psi @ 600 F. For higher pressures, use bulb well No. 97181.

**Pressure Gages:** (Two supplied) ..... Dual scale dials graduated 0-30 psi and 0-2.1 Kg/Cm<sup>2</sup> or 0-60 psi and 0-4.2 Kg/Cm<sup>2</sup>.

### Materials:

**Bulb**.....Type 304 stainless steel welded to stainless steel fitting.

**Actuating Rod (inside Bulb)** ..... Invar, Nickel plated.

**Pilot Valve** ..... Type 303 stainless steel.

**Housing and Other Parts** ..... Brass or Bronze.

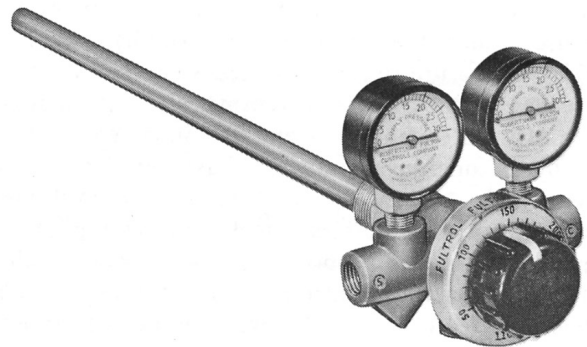

### FEATURES

- Non-indicating type for pneumatic control systems.
- Ranges to 350 F.
- Control Point Adjustable over 200 F. spans.
- "Overrun" Temperature Protection
- Adjustable Proportional Band
- Control Action Easily Reversible in Field
- Simple, Straightforward Design, No Levers or Pivots

  
An Invensys company

## DIMENSIONS

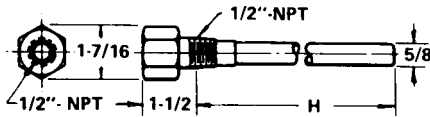
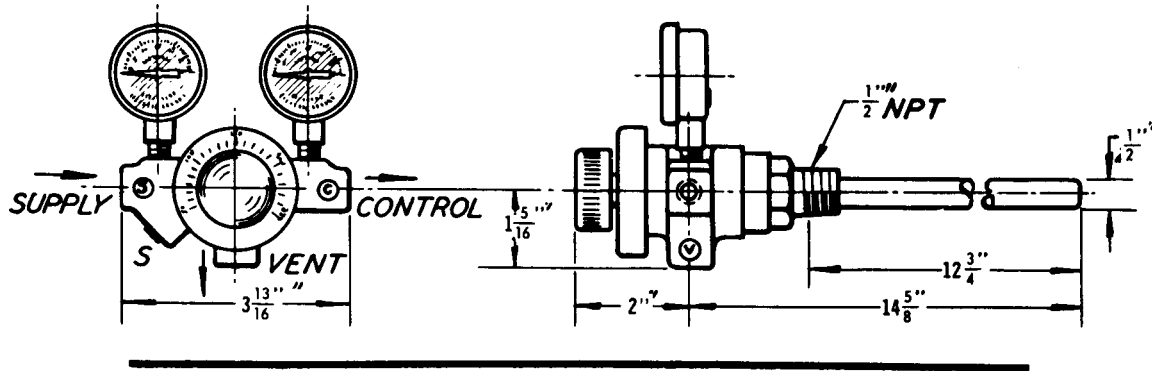

## DIMENSIONS

BULB WELL NO. 97181

For FulTrol bulb where high pressures or extreme corrosives are encountered. Stainless steel. Maximum non-shock pressure: 1000 psi at 150°F., 750 psi at 350°F.

## OPERATION

The FULTROL controller uses the familiar rod and tube principle to control the pilot pressure applied to final control devices such as diaphragm control valves as temperature around the sensing element (bulb) rises and falls.

On temperature rise, the stainless steel tube which forms the outer member of the sensing element increases in length. Its outer (moving) end is connected to the pilot valve by an inner invar rod which has a very low coefficient of expansion. Thus the pilot valve is repositioned by movement of the stainless steel tube, and pilot output (control) pressure is proportional to temperature changes. With a direct-acting controller, output pressure increases with rising temperature. A reverse-acting controller produces decreasing output pressure as temperature rises.

Fig. 1 shows the internal schematic of the pilot controller. The thermostatically actuated pilot valve is in the vent line. Supply pressure is admitted through an adjustable orifice, the setting of which determines the controller's proportional band. On direct acting models, low temperature at the sensing bulb gives maximum vent valve opening to increase the rate of bleed beyond the capacity of the orifice and thus the output pressure passed through to the final control device is decreased. With the pilot valve reversed, flow through the vent port is reduced to a minimum with low temperatures and supply pressure flowing through the adjustable orifice exits through the output port until output pressure approaches supply pressure values.

## ACCESSORIES

**PRESSURE REDUCING VALVE** No. 97478 - Reduces air supply to 18 psi for operation of control valves, etc. Includes filter and drip well. 1/4" NPT female connections. Hex head adjusting screw or bakelite knob furnished as specified.

**BOOSTER RELAY** No. CR-100-A 1 - Gives faster response on pneumatic systems requiring substantial air volume. All connections are 1/4" NPT female.

## CONTROL VALVES

Suitable for steam, gas, oil, water or other fluids. Valve sizes 1/4" thru 4". Both bellows actuated and diaphragm actuated types available.

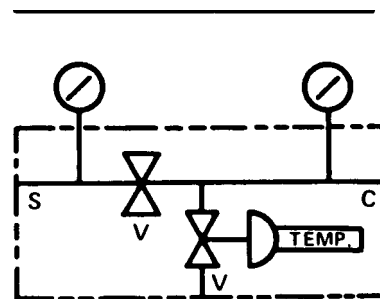

Figure 1

## APPLICATIONS

These application diagrams illustrate the use of the FulTrol Pilot Controller with Robertshaw's No. VC-230 and VC-231 diaphragm control valves. In all cases, the temperature sensing element of the FulTrol is assumed to be in the medium under control.

### HEATING

FulTrol Action	Control Valve Type	Valve Action Rising Temperature	Valve Position Pilot Supply Failure
Direct	VC-230 w/ D.A. Valve VC-231 w/ R.A. Valve	Closes	Opens
Reverse	VC-230 w/ R.A. Valve VC-231 w/ D.A. Valve	Closes	Closes

### COOLING

FulTrol Action	Control Valve Type	Valve Action Rising Temperature	Valve Position Pilot Supply Failure
Direct	VC-230 w/ R.A. Valve VC-231 w/ D.A. Valve	Opens	Closes
Reverse	VC-230 w/ D.A. Valve VC-231 w/ R.A. Valve	Opens	Opens

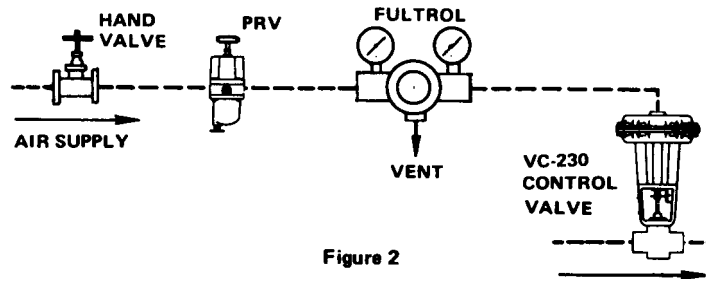

Figure 2

### HEATING AND COOLING

One air-to-close control valve and one air-to-open valve positioned by a direct-acting or reverse-acting FulTrol Pilot Controller, provide temperature control of a solution that must be heated to a specified point and then maintained at that temperature by a cooling means. Viz.; chrome plating process.

FulTrol Action	Control Valve		Valve Action on Temperature Rise		Valve Position on Pilot Supply Failure	
	Heating Valve	Cooling Valve	A	B	A	B
DIRECT	VC-230 w/ D.A. Valve VC-231 w/ R.A. Valve	VC-230 w/ R.A. Valve VC-231 w/ D.A. Valve	Closes	Opens	Opens	Closes
REVERSE	VC-230 w/ R.A. Valve VC-231 w/ D.A. Valve	VC-230 w/ D.A. Valve VC-231 w/ R.A. Valve	Closes	Opens	Closes	Opens

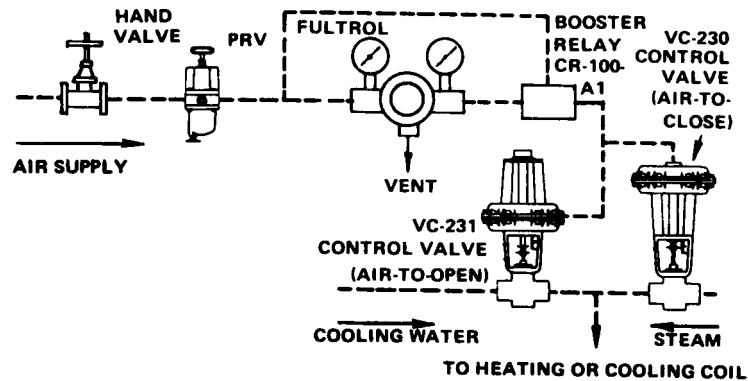
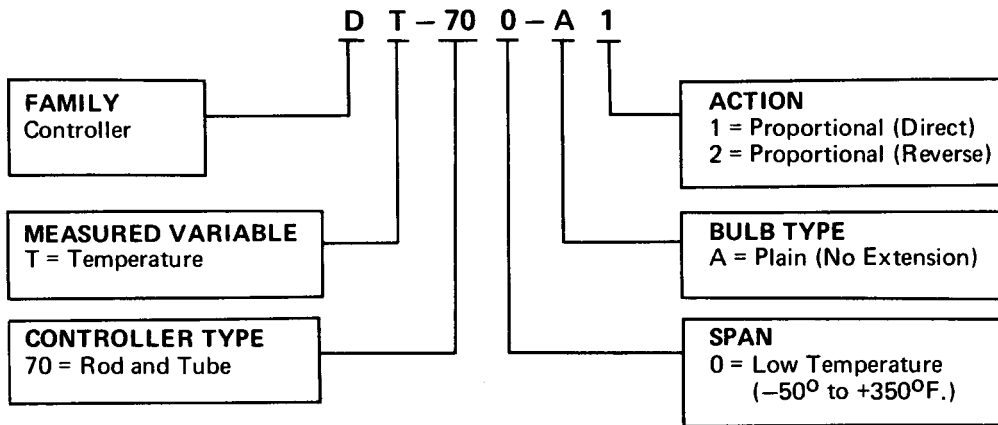

Figure 3

## MODEL IDENTIFICATION



## HOW TO ORDER

### Specify:

1. FulTrol model number (See model Ident.)
2. Quantity
3. Temperature Range
4. Control action (Direct- or Reverse-acting)
5. Operating pressure
6. Supply medium
7. Corrosive conditions, if any
8. Accessories
9. Invoicing and Shipping instructions.

# Robertshaw

## U.S.A. and CANADA

Robertshaw Industrial Products Division  
1602 Mustang Drive  
Maryville, TN 37801  
Phone: (865) 981-3100 Fax: (865) 981-3168  
<http://www.robertshawindustrial.com>

## Exports

Invensys Appliance Controls  
2809 Emerywood Parkway  
P.O. Box 26544  
Richmond, Virginia 23261-6544  
Phone: (804) 756-6500 Fax: (804) 756-6561