

**VIBRASWITCH®**  
**MALFUNCTION**  
**DETECTOR**  
**Model EURO 366G**

**GENERAL DESCRIPTION**

The Model EURO 366G **VIBRASWITCH®** is primarily intended for indoor and outdoor hazardous and non-hazardous areas, more specifically areas exposed to salt water, and in those countries requiring ATEX and CE certifications. The EURO 366G employs the same time proven switch design found in Robertshaw's family of vibration switches.

The Model EURO 366G **VIBRASWITCH®** is a vibration sensitive device that protects rotating and reciprocating machinery from extensive damage resulting from mechanical malfunction. When the vibration level of a **VIBRASWITCH®** protected machine exceeds normal by a preselected amount, the normally open contacts of an internal switch close and the normally closed contacts open. This can be used to actuate either an audible warning system or a shutdown circuit before costly damage occurs.

Failing bearings, broken blades and similar malfunctions cause increased imbalance or high frequency vibration detectable with the **VIBRASWITCH®**. It is designed for maintenance-free service in permanent installations.

The **VIBRASWITCH®** is an acceleration sensitive instrument that measures the total acceleratory shock present on the machine. Acceleration is a vibration characteristic of prime importance in cases of mechanical failure on reciprocating or rotating machinery. Acceleration is directly related to the shock forces (impact) acting on a machine - thus the **VIBRASWITCH®** offers a valid measurement of the destructive forces acting on the machine.

Accelerator measurements made by the **VIBRASWITCH®** are the summation of all of the individual accelerations giving a **total** destructive force acting on the machine - the result is **positive** protection.

**PRINCIPLE OF OPERATION**

The Model EURO 366G **VIBRASWITCH®** employs a magnetic circuit opposed by inertial and adjustable spring forces in the actuating mechanism. Operation of the **VIBRASWITCH®** may be understood by reference to Figure 1.

The armature is constrained so as to respond to only one direction of movement by a frictionless flexure pivot composed of two overlapping blocks and a leaf spring loaded in one direction to hold the blocks together. The armature rotates on the pivot being forced in one direction by the adjusting spring force and the other direction by the magnetic force.



**VIBRASWITCH® MODEL EURO 366G**

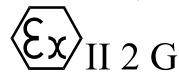

**EEx d IIB/C T6 IP66 T85°C – CESI 03 ATEX 186**

**FEATURES AND BENEFITS**

- **Flame Proof (Explosion Proof)**  
EEx d IIC T6 IP65 T85°C - INERIS 02ATEX0043
- **Self Powered**  
Does not require any form of external power to operate.
- **Acceleration Sensitive**  
Measures total destructive shock, not displacement.
- **Minimum Maintenance**  
No moving parts except when set-point is exceeded.
- **Continuous Protection**  
No attention required after installation.
- **Ease of Installation**  
Requires no special training.
- **Long Life**  
Instrument is rugged and durable - no wearing parts.
- **Reset**  
Manual at unit and choice of remote electrical.
- **AC or DC**  
Reset coil options.
- **IP66 Cast Iron Enclosure**  
For outdoor and indoor use.

When the entire assembly is subjected to vibration perpendicular to the base, the peak acceleration times the effective mass of the armature produces an inertial force, aided by the adjustable spring tending to pull the armature away from the stop pin and the restraining force of the magnet. When peak acceleration exceeds the set-point level the armature leaves the stop pin, increasing the gap and decreasing the force with the armature continuing to move up until it reaches the latch magnet, actuating the switch during its upward travel.

The **VIBRASWITCH®** may be reset by depressing the reset button or by applying power to the electrical reset coil. The effect of temperature in the mechanism is negligible as the elastic modulus of the adjusting spring and the magnetic flux through the air gap both decrease slightly with increasing temperature thereby compensating each other.

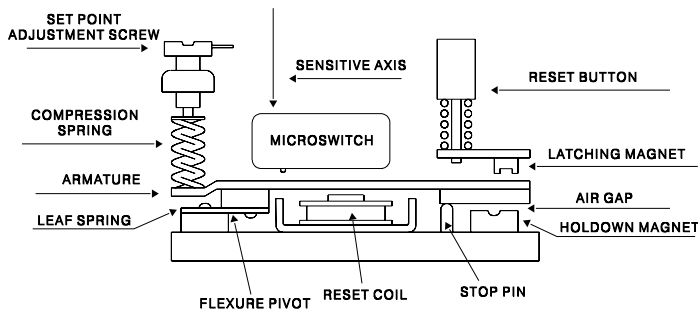

**Figure 1**

## **SPECIFICATIONS**

### **ENVIRONMENTAL**

Enclosure .....	Cast Iron EN-GJL200
Weight Model CS-INVR-216 .....	5.5 kg (12.0 lb)
Enclosure Classification .....	Flame (Explosion) proof EEx-d-IIB/C-T6 IP66 T85° C
Flame Proof Certification .....	CESI 03 ATEX 186
Enclosure Protection .....	IP66 Standard
Enclosure Finish .....	Electrolytic Zinc plated & Epoxy Painted(Standard) ..... Electrolytic Zinc Plated & Thermoset polymer powder coated(Optional)
Mounting Location .....	Outdoors, unprotected
External Bolts .....	Stainless steel
Nameplate .....	Stainless steel
Conduits .....	2 x 3/4" UNI 6125-74 (will accept 3/4 NPT fitting)
Ambient Temperature Limits .....	-20°C to +40°C(Standard) ... (Anti-condense painted into enclosure) -40°C to +60°C(Optional)
Humidity .....	To 95% relative humidity ..... @ 37.7° C (100° F)
Shock .....	40 g @ 11 ms maximum

### **ELECTRICAL**

Switch Configuration .....	See table 1
Contact Rating .....	See table 5

### **PERFORMANCE**

Vibration Measurement Range (Peak)	
Mounted Horizontal .....	0 to 4.5 g from 0 to 300 Hz
Mounted Vertical .....	0 to 3.5 g from 0 to 300 Hz
Set Point Adjustment .....	1 turn per g
Accuracy .....	± 5% of full range from 0 to 300 Hz
Ambient Temperature Effect .....	± 10%/55.5° C ..... (132° F) maximum

### **RESET COIL**

Duty Cycle	
All except 240 VAC coils .....	4 minutes ON max, ..... 10 minutes OFF min
240 VAC coil .....	1 minute ON max, ..... 10 minutes OFF min
Voltage .....	See Table 2
Current .....	See Table 2

#### Notes:

1. 3/4" UNI opening will also accept 3/4" NPT fittings.
2. Plug may be discarded if not required.
4. Space heaters are intended to prevent condensation in the enclosure where climate conditions require. Space heaters are not required in most applications.

# ORDERING INFORMATION

Specify complete model number according to the tables below.

**EURO 366G-A 8 - H 2 - A - X -X**

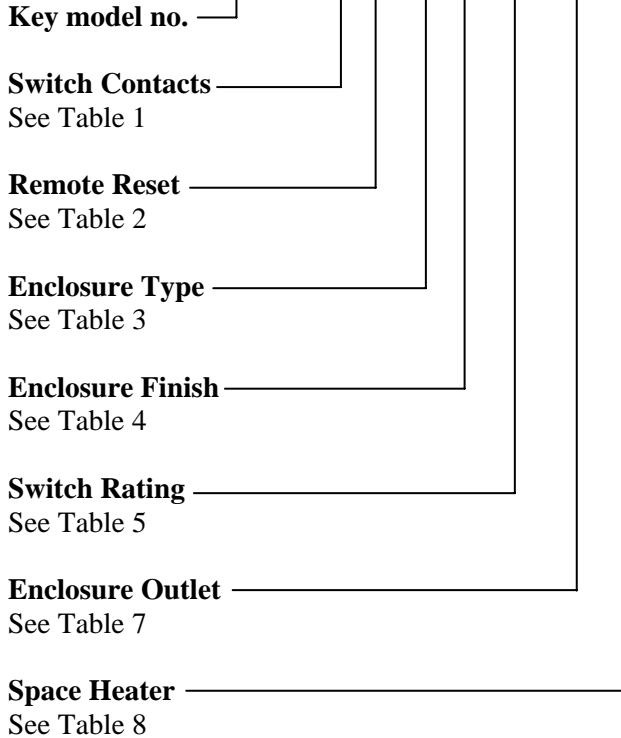

**Key Model Number**

Designation	Description
EURO 366G	Flame proof IP66 Vibraswitch® Cast Iron Enclosure

**Table 1 - Switch Contacts**

Designation	Description
A	SPDT - single pole double throw load contacts
D	DPDT - 2 gang mounted SPDT load switches

**Table 2 - Remote Reset**

Designation	Description
0	No reset coil
2	24 VDC, 0.5 amp
4	48 VDC, 0.2 amp
7	120 VDC, 0.14 amp
8	120 VAC, 0.3 amp, 50/60 Hz
9	240 VAC, 0.3 amp, 50/60 Hz

**Table 3 - Enclosure Type**

Designation	Description
W	CS-INVR T. cable 105°C T. amb. -40 to +55°C

**Table 4 - Enclosure Finish**

Designation	Description
2	Electrolytic Zinc Plated & Epoxy Painted
3	Electrolytic Zinc Plated & Thermoset Polymer Powder Coated (Optional)

**Table 5 - Switch Rating**

Designation	Description
A	Use with Table 1 designation A only. SPDT 7 amp max, 460 VAC max, NI; 0.5 amp at 120 VDC; 1 amp at 48 VDC; 2 amp at 24 VDC 5 amp at 12 VDC
E	Use with Table 1 designation D only. DPDT 5 amp max, 250 VAC max, NI; 5 amp max at 30 VDC
H	Use with Table 1, designation D only. DPDT with IP67 protection (sealed) and gold plated contacts for low voltage/current circuits. Suitable for intrinsically safe applications. 0.1 amp max at 125, 250 VAC, RES. 0.1 amp max at 30 VDC, RES. 5.0 mA min at 6 VDC, RES. 2.0 mA min at 12 VDC, RES. 1.0 mA min at 24 VDC, RES.

**Table 7 - Enclosure Conduit Entrance**

Designation	Description
X	3/4" UNI 6125 opening, 3/4" UNI plug (See notes 1 & 2)

**Table 8 - Space Heater (See note 3)**

Designation	Description
F	24 VDC, 2 watt
G	48 VDC, 2 watt
H	120 VAC, 2 watt
L	120 VDC, 2 watt
M	240 VAC, 2 watt
X	No space heater

# CUSTOMER ELECTRICAL CONNECTIONS

## EURO 366G-D (DPDT Switch)

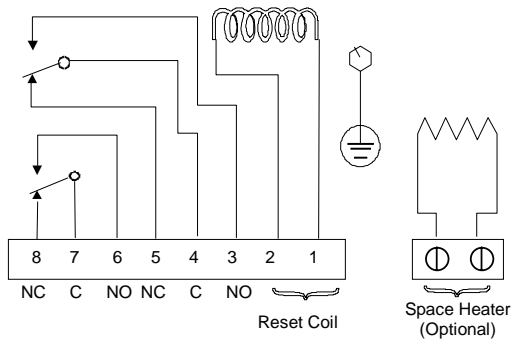

## EURO 366G-A (SPST Switch)

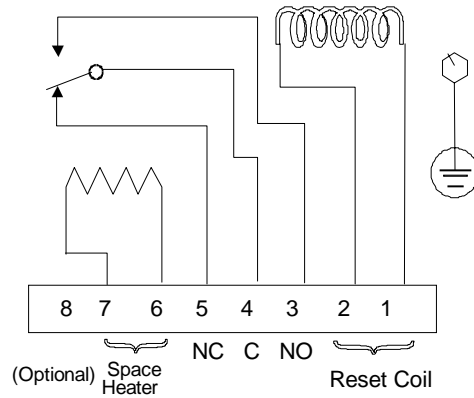

# OUTLINE DIMENSIONS

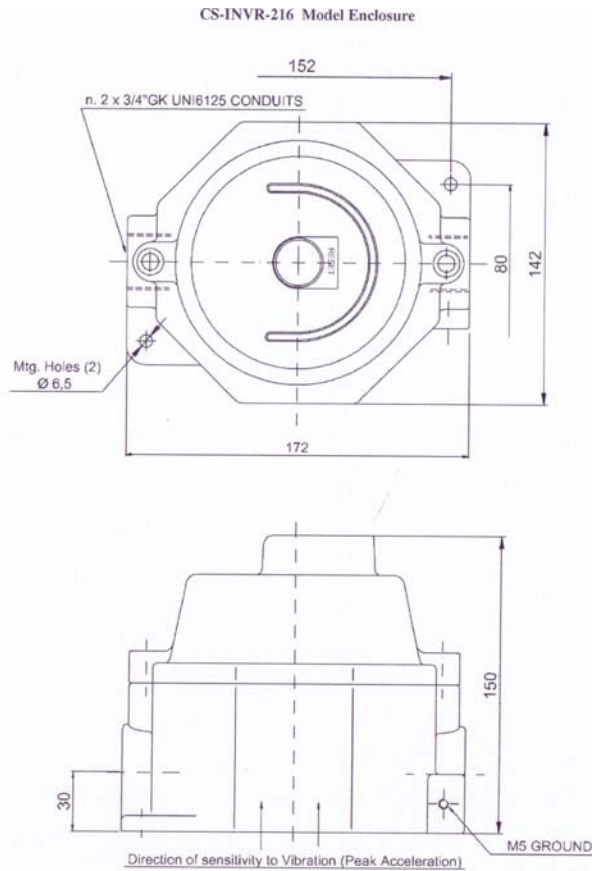

Figure No. 4



**Robertshaw Industrial Products Division**  
 1602 Mustang Drive  
 Maryville, Tennessee 37801  
 Phone: (865) 981-3100 Fax: (865) 981-3168  
<http://www.robertshawindustrial.com>  
 Q-4170 (12/07) Printed in U.S.A

**Invensys®**