

LARGE DISPLAY PROCESS METERS

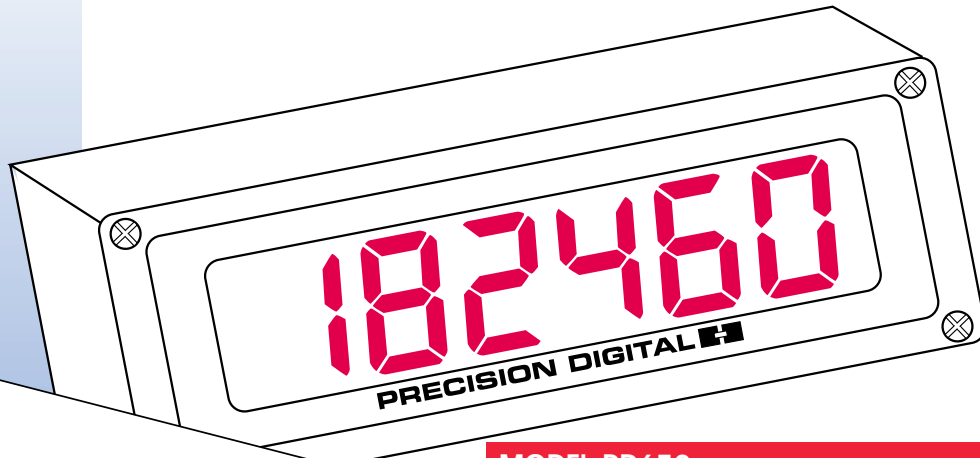

MODEL PD650
NEMA 4X 2.3" HIGH RED LED

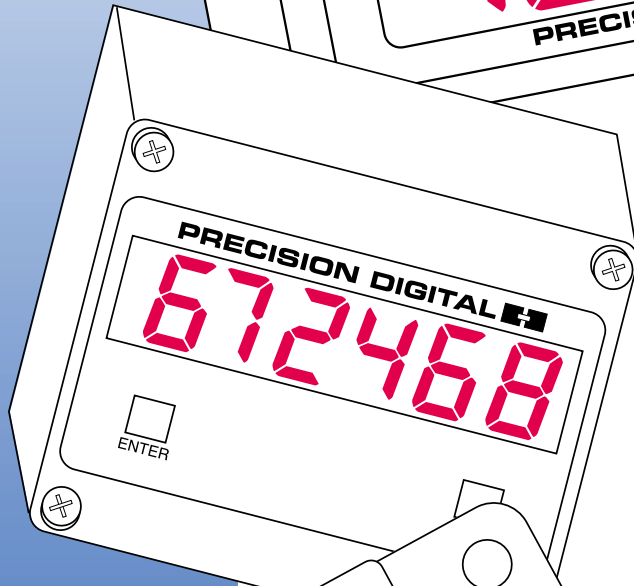

MODEL PD655
NEMA 4X 1.0" HIGH RED LED

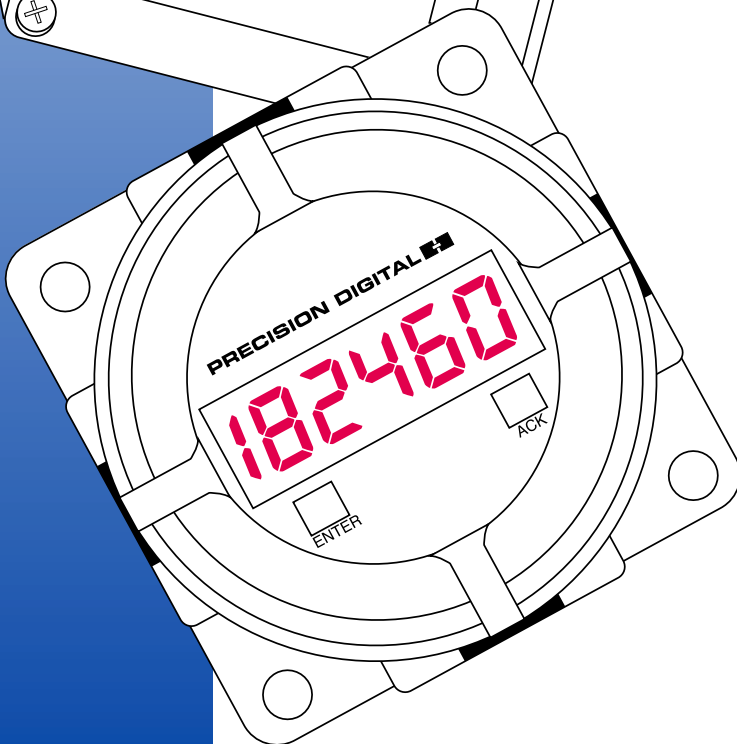

MODEL PD656
EXPLOSION-PROOF 0.8" HIGH RED LED

- 4½ Digit + Extra Zero Display for Process/Rate
- Full Six Digit Display for Total
- Easy Single Button Scaling
- Two 24 VDC Isolated Power Supplies
- Modification for 200 mA Power Supply Available!
- 2 or 4 Relays + 4-20 mA Output Options

**MODEL PD650 NEMA 4X 2.3" HIGH RED LED
CAST ALUMINUM ENCLOSURE**

ORDERING INFORMATION

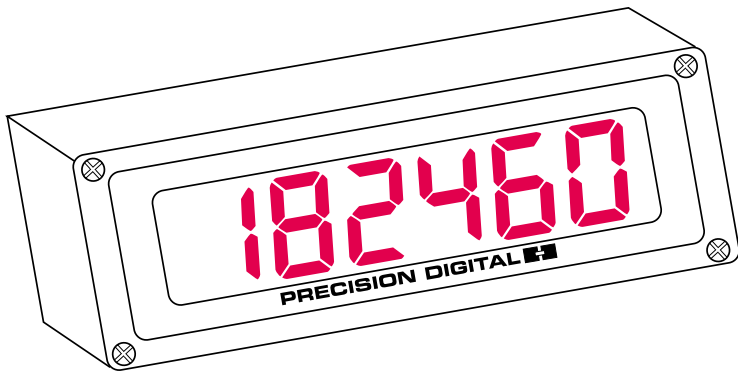

115/230 VAC	24 VDC	
MODEL	MODEL	DESCRIPTION
PD650-N	PD650-2-N	No Options
PD650-34	PD650-2-34	2 Relays
PD650-35	PD650-2-35	4-20 mA Output
PD650-36	PD650-2-36	2 Relays + 4-20 mA Output
PD650-37	PD650-2-37	4 Relays
PD650-38	PD650-2-38	4 Relays + 4-20 mA Output

OPTION CARDS	
MODEL	DESCRIPTION
PD374	2 Relays
PD375	4-20 mA Output
PD376	2 Relays + 4-20 mA Output
PD377	4 Relays
PD378	4 Relays + 4-20 mA Output

ACCESSORIES	
MODEL	DESCRIPTION
PDA6504*	Panel Mounting Kit

**Does not provide NEMA 4X seal to panel.*

MODEL PD655 NEMA 4X 1.0" HIGH RED LED

ORDERING INFORMATION

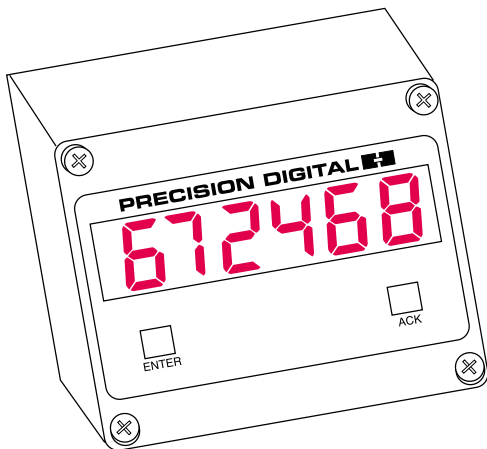

115/230 VAC	24 VDC	
MODEL	MODEL	DESCRIPTION
PD655-N	PD655-2-N	No Options
PD655-44	PD655-2-44	2 Relays
PD655-45	PD655-2-45	4-20 mA Output
PD655-46	PD655-2-46	2 Relays + 4-20 mA Output
PD655-47	PD655-2-47	4 Relays
PD655-48	PD655-2-48	4 Relays + 4-20 mA Output

OPTION CARDS	
MODEL	DESCRIPTION
PD474	2 Relays
PD475	4-20 mA Output
PD476	2 Relays + 4-20 mA Output
PD477	4 Relays
PD478	4 Relays + 4-20 mA Output

ACCESSORIES	
MODEL	DESCRIPTION
PDA6554*	Panel Mounting Kit
PDA6545	2" Pipe Mounting Kit

**Does not provide NEMA 4X seal to panel.*

**MODEL PD656 EXPLOSION-PROOF
0.8" HIGH RED LED**

ORDERING INFORMATION

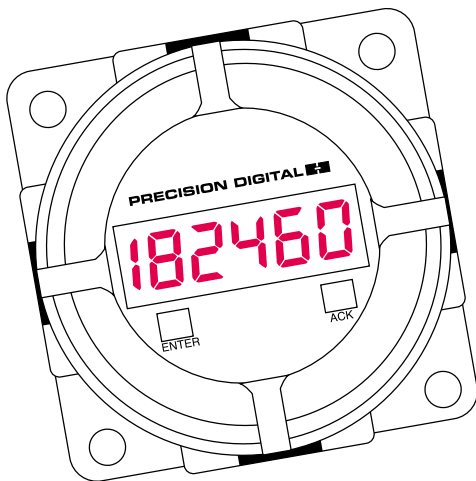

115/230 VAC	24 VDC	
MODEL	MODEL	DESCRIPTION
PD656-N	PD656-2-N	No Options
PD656-44	PD656-2-44	2 Relays
PD656-45	PD656-2-45	4-20 mA Output
PD656-46	PD656-2-46	2 Relays + 4-20 mA Output
PD656-47	PD656-2-47	4 Relays
PD656-48	PD656-2-48	4 Relays + 4-20 mA Output

OPTIONS & ACCESSORIES	
MODEL	DESCRIPTION
PD474	2 Relays
PD475	4-20 mA Output
PD476	2 Relays + 4-20 mA Output
PD477	4 Relays
PD478	4 Relays + 4-20 mA Output
PDA-MAG	Magnet Assembly
PDA6545	2" Pipe Mounting Kit

CONTROL STATIONS		
MODEL	SWITCHES	LABELS
PDA2451-E	1	See Below
PDA2451-A	1	
PDA2451-R	1	
PDA2452-EA	2	
PDA2452-ER	2	
PDA2453-EAR	3	

Labels:
E = Enter, A = Ack, R = Reset

GENERAL FEATURES

The PD650, PD655 and PD656 are Large Display Process Meters with flow rate, totalizer and batch control capabilities. Each accepts the common process signals such as 4-20 mA, 0-5 VDC, 1-5 VDC and 0-10 VDC and displays these signals in engineering units on a large, high efficiency, 4½ digit red LED display. All units also provide two isolated 24 V power supplies to drive both the input and output loops. Options include up to 4 relays for alarms or batch controlling, as well as an isolated 4-20 mA transmitter output.

First Time Features

- Two 24 VDC isolated transmitter power supplies
- 115 or 230 VAC field selectable power
- Rate display in units per day, in addition to second, minute and hour
- Programmable set points for latching and non-latching relay operation
- Built-in snubbers on each relay contact
- Any set point programmable for process/rate or total
- Programmable root function for Weirs and Flumes
- Pump Alternation

Single Button Scaling with One Touch Calibration Bail-Out

The Large Display Process Meters are completely programmed using only one button. Press ENTER to start menu scanning; then select the menu; then your desired value. Programming ease is now enhanced in these meters by a one touch calibration bail-out with the use of the ACK (Acknowledge) button.

Stand Alone Scaling (Internal or External)

These meters may be calibrated with or without applying a calibrated signal.

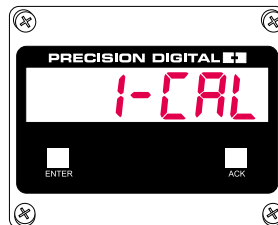

Lockout and Menu-Title Disabling

The ability to modify programming values can be restricted by installing a lockout jumper on terminals at the rear of the instrument. In addition, certain menu titles can be programmed not to appear during the menu scroll with the display menu.

Menu titles that can be excluded with dSPLY menu functions.

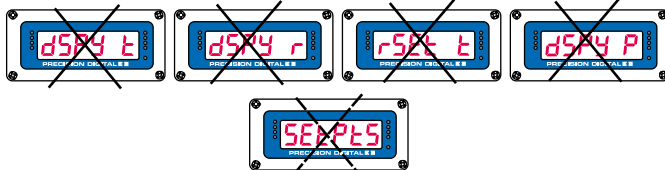

SEtPE5 Menu title always appears.

Ability to change values may or may not be restricted

Functions that can be locked out with the lockout jumper.

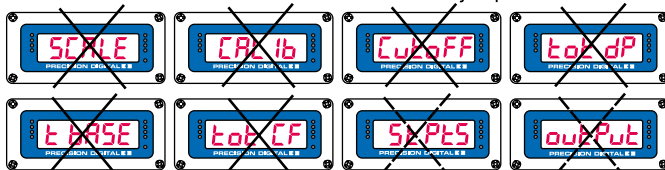

Large, Bright, High Efficiency Red LEDs

The large, bright, high efficiency red LED display of these new Large Display Process Meters is designed to make it easy to read these displays from far away in a dimly lit process plant.

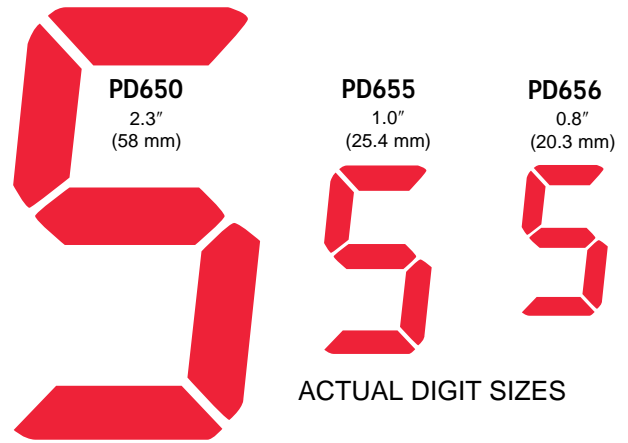

Simplify Loops with Two 24 V Supplies

The PD650, PD655 and PD656 are ideal for loops that consist of a transmitter, a digital meter and a DCS or computer because they can provide isolated power to drive both the input and output loops.

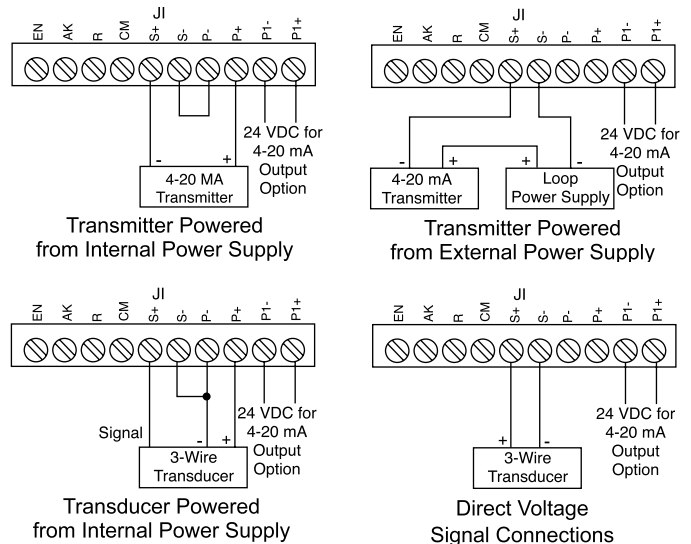

Universal Process Inputs & Linearization

The Large Display Process Meters accept both voltage and current inputs and can be scaled for virtually any engineering unit. In addition, these meters feature automatic square root extraction, programmable root function for weirs and flumes and 11-point custom calibration.

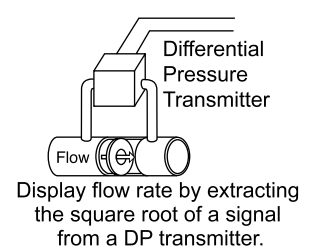
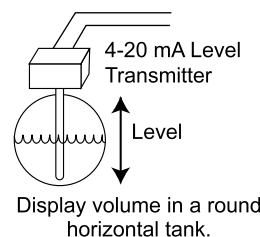

FLOW FEATURES

The Large Display Process Meters may be used to display flow rate and total from a wide variety of flow meters. For flow rate applications, these meters feature programmable time base of seconds, minutes, hours, or days, a 4 1/2 digit plus extra zero display, and low-flow cutoff capability. For total applications, these meters feature a full six-digit display, a programmable totalizer conversion factor and the ability to automatically or manually toggle back and forth between a display of rate and total. New features include Programmable Root function for Weirs and Flumes.

OPTIONS

The Large Display Process Meters can be equipped with 2 or 4 SPDT relays and 4-20 mA output options. Any one of the relays can be programmed to function on the rate or the total. The 4-20 mA output option provides signal isolation and can be scaled for a wide variety of applications.

Rate Relays

Rate relays are field programmable as latching or non-latching and 0-100% adjustable deadband. They can be used as high or low alarms or for simple on-off control, such as sump-pump control. Pairs of rate relays can also be programmed to alternate making these meters ideal for duplex pumping applications.

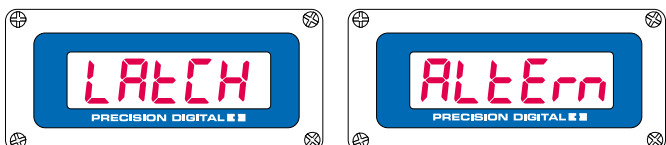

Total Relays

Total relays can be programmed for manual (E for External Reset) or automatic (I for Internal Reset) batch control. To simplify and speed up batch-size changes, total relays can be programmed so the first preset always trips at a user-defined offset value before the main preset trips. In addition, the Priority Batch Programming feature allows the user to program the batch presets without having to go through the entire menu. Simply hold the ENTER button for three seconds and the meter jumps right to the batch presets.

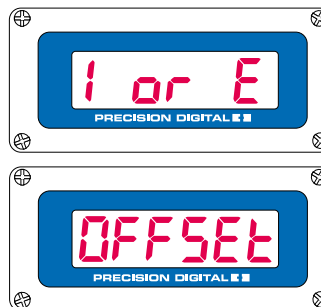

4-20 mA Output Option

The Large Display Process Meters can be equipped with an isolated 4-20 mA output signal option that can be programmed to produce a 4-20 mA output for virtually any input. These meters also contain two transmitter power supplies so even if the meter is powering the input loop, it can still power the output loop. The 4-20 mA output provides 500 VDC or peak AC, input-to-output or input/output-to-power isolation.

PUMP ALTERNATION

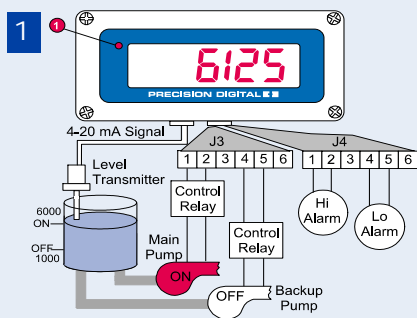

Relay #1 turns the main pump on at 6000 gallons and turns it off at 1000 gallons.

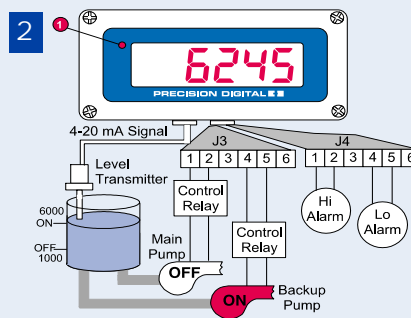

With the Pump Alternation feature activated, the next time the level reaches 6000 gallons, relay #2 transfers and starts the backup pump.

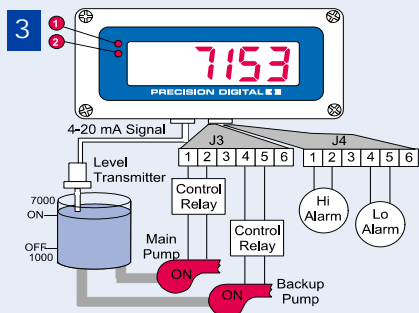

The backup pump is not able to keep up, so when the level reaches 7000 gallons, relay #1 transfers and starts the main pump.

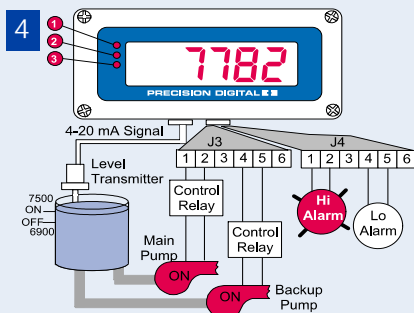

Relay #3 trips the High Level Alarm at 7500 gallons and resets at 6900 gallons.

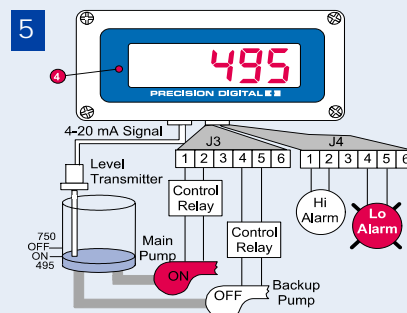

Relay #4 trips the Low Level Alarm at 495 gallons and resets at 750 gallons.









OPTION CARD PIN-OUTS

Pin	Function
J1 {	1 Transmitter +
	2 Transmitter -
J3 {	1 Relay #1 Common
	2 Relay #1 NC
	3 Relay #1 NO
	4 Relay #2 Common
J4 {	5 Relay #2 NC
	6 Relay #2 NO
J4 {	1 Relay #3 Common
	2 Relay #3 NC
	3 Relay #3 NO
	4 Relay #4 Common
	5 Relay #4 NC
	6 Relay #4 NO

Notes:
 1. Alarm acknowledgement terminals (AC and COM) are located on the meter main board.
 2. In the alarm condition, the NC contact is connected to common in the fail safe mode.

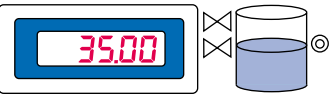
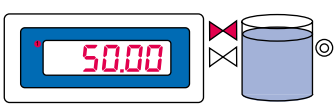
Manual Batch Control Operation

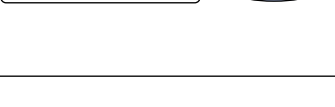
This example shows how the PD650 can be used for simple manual batch control:

The valve and External Switch KEY Legend is as shown:	KEY  = VALVE CLOSED  = VALVE OPEN  = External RESET Switch  = External RESET Switch Pressed
Both valves are open to fill the barrel. Meter displays barrel contents.	
Full-flow valve #1 is closed and restricted-flow valve #2 "dribbles" in the remaining 5 gallons.	
When the total reaches 55.00, relay 2 trips and closes restricted-flow valve #2. Display freezes on 55.00 and relays 1 and 2 will not reset until external switch is pushed.	
Both valves are still closed and a new barrel is positioned. Meter displays previous barrel's contents until external reset button is pushed.	
Operator presses reset switch to reset total. Total goes to zero. Both relays reset causing both valves to open and begin filling the new barrel.	
Both valves are open to fill the barrel. Meter displays barrel contents.	

Explosion-Proof Control Stations for the PD656

The explosion-proof control stations can be used to control the PD656 while in operation in a hazardous area. Control stations may be ordered with one, two or three push buttons. The buttons can be labeled ENTER, ACK and RESET. External connections are available at J1 connector on the main PCB.

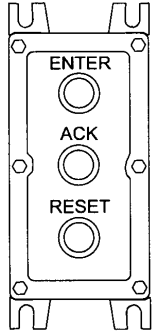

Front Panel LED Indicators

LED	During Programming:	During Operation:
1	Alarm 1	Alarm 1
2	Alarm 2	Alarm 2
3	Alarm 3	Alarm 3
4	Alarm 4	Alarm 4
S	Set Point Indicator	None
R	Reset Point Indicator	None
4	4 mA Output Indicator	None
20	20 mA Output Indicator	None
R	Rate Indicator	Rate

Front Panel LEDs for PD650

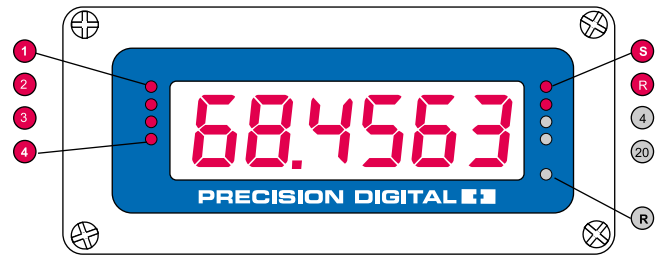

Magnetic Reed Switch Operation

The PD656 has two magnetic reed switches located above the ENTER and ACK buttons. The reed switches allow the user to program and operate the meter without having to remove the enclosure cover.

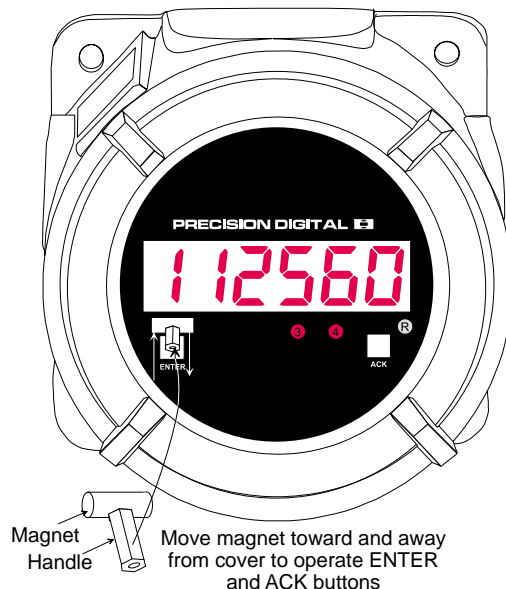

OVERALL DIMENSIONS

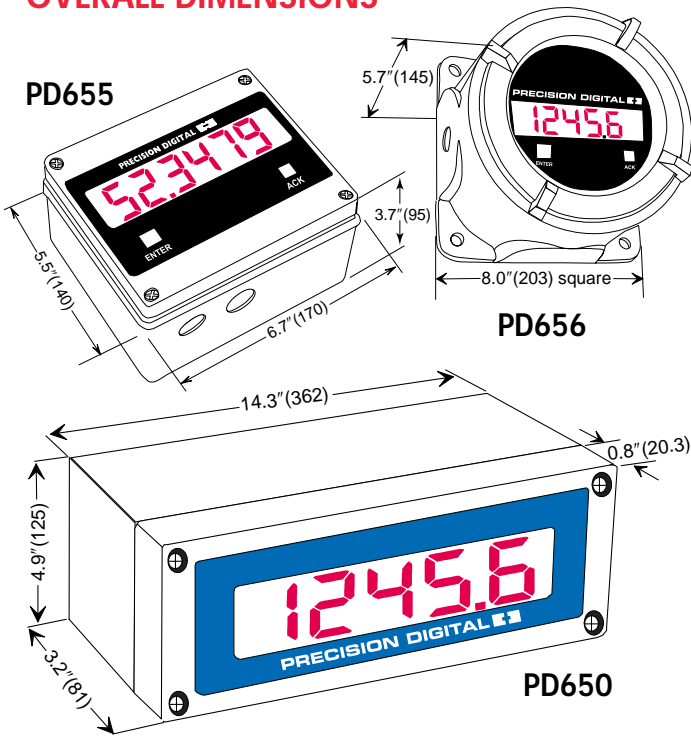

WALL MOUNTING

There are four mounting holes on the rear of the enclosure that are used to mount the instrument to a wall.

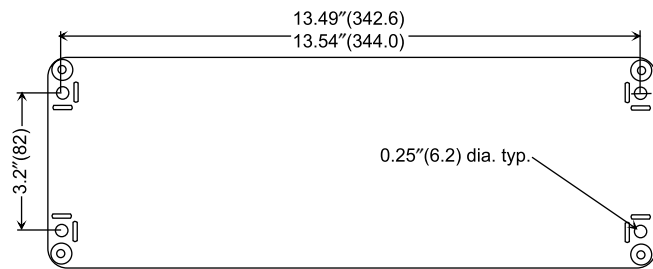

PD650 Wall Mounting

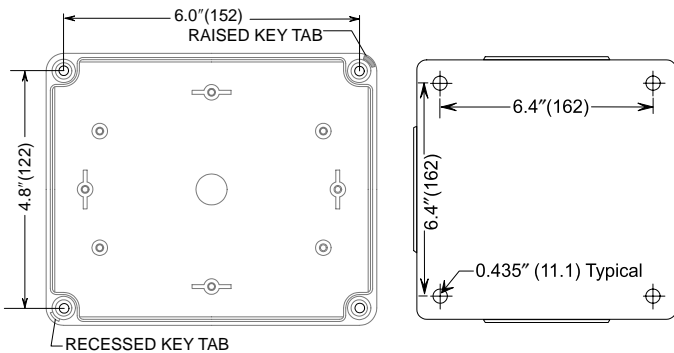

PD655 Wall Mounting

PD656 Wall Mounting

Designed for vertical or horizontal conduit entry.

PANEL MOUNTING

PD650 Panel Mounting Kit - PDA6504

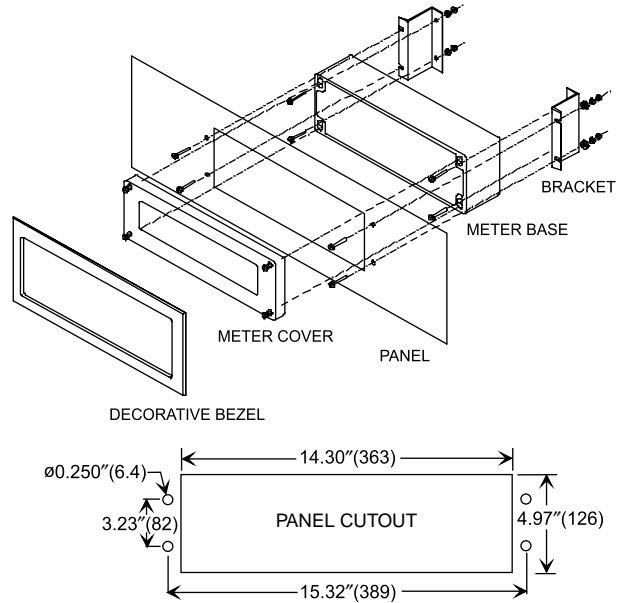

NOTES:

- a. Allowable panel thickness: 0.06" – 0.25" (1.5 mm – 6.4mm)
- b. Mounting space required: 7" x 17.5" x 4" (178 mm x 44 mm x 102 mm) (HxWxD)
- c. Panel Mount Kit does not provide NEMA 4X seal to panel

PD655 Panel Mounting Kit - PDA6554

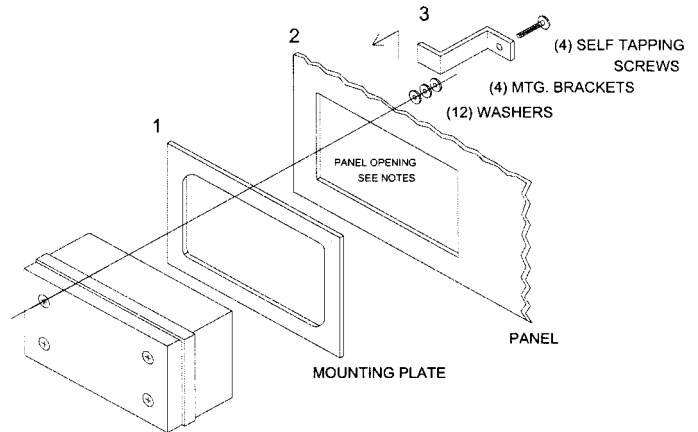

NOTES:

- a. Allowable panel thickness: 0.06" – 0.125" (1.5 mm – 3.2 mm)
- b. Panel Cutout required: 6.57" x 5.40" (167 mm x 137 mm)
- c. Mounting space required: 7.6" x 6.4 x 2.8" (193 mm x 163 mm x 71 mm) (HxWxD) plus mounting brackets require 0.8" (20 mm) on either top or side of meter for installation
- d. Panel Mount Kit does not provide NEMA 4X seal to panel

SPECIFICATIONS

Except where noted all specifications apply to operation at +25°C.

PD650 NEMA 4X 2.3" High Red LED

DISPLAY: 2.3" (58.4 mm) high efficiency red LED

ENCLOSURE: Die-cast aluminum, NEMA 4X, IP 66/IP 67.

Corrosion resistant, copper content under 0.1%, color: gray (RAL 7001) polyester powder paint. Four holes for 1/2" conduit provided at base, 3 plugs provided.

MOUNTING: Enclosure contains four 1/4" holes for wall-mounting. Panel Mounting Kit available.

OVERALL DIMENSIONS: 4.9" x 14.3" x 3.2" (125 x 362 x 81 mm)

WEIGHT: 7.0 lbs (3.2 kg)

PD655 NEMA 4X 1.0" High Red LED

DISPLAY: 1.0" (25.4 mm) high efficiency red LED

ENCLOSURE: Impact-resistant glass-filled polycarbonate, NEMA 4X, IP 67 (IEC 529), color: gray (RAL 7035). Two holes for 1/2" conduit provided at base.

MOUNTING: Enclosure contains four holes for wall-mounting. Panel Mounting and 2" Pipe Mounting Kits available.

OVERALL DIMENSIONS: 6.7" x 5.5" x 3.7" (170 x 140 x 95 mm)

WEIGHT: 3.8 lbs (1.73 kg)

PD656 Explosion-Proof 0.8" High Red LED

DISPLAY: 0.8" (20.3 mm) high efficiency red LED

ENCLOSURE: Explosion-proof sand-cast aluminum, 0.3% max. copper content, NEMA 3, 4, 7, 9, IP 66. For use in hazardous locations Class I Groups C & D, Class II Groups E, F & G; UL Classified, Class I, Zone 1. Two 3/4" NPT holes provided at opposite sides. Up to four holes can be provided for an additional charge.

MOUNTING: Enclosure contains four 7/16" holes for wall-mounting. 2" Pipe Mounting Kit available.

OVERALL DIMENSIONS: 8.0" x 8.0" x 5.7" (203 x 203 x 145 mm)

WEIGHT: 14.6 lbs (6.6 kg)

Basic Meter Specifications for All Units

INPUTS: Field selectable: 4-20 mA, 0-20 mA, 0-5 V, 1-5 V, 0-10 V

DISPLAY: 6 Digit red LED, -19,999(0) to 29,999(0) with selectable extra zero. Total: 0 to 999,999. Automatic lead zero blanking.

DECIMAL POINT: Process/rate: 2.9999, 29.999, 299.99, 2999.9 or 29999.0. Total: 9.99999, 99.9999, 999.999, 9999.99, 99999.9. Rate and total decimal points are independent.

CALIBRATION RANGE: 4 mA (1 V) input may be set anywhere in range of the meter. 20 mA (5 V) may be set anywhere in range of the meter above or below 4 mA input. An Error message will appear if Input 1 signal and Input 2 signal are too close together.

Input Range	Minimum Difference Between Input 1 & Input 2
0-5 V	0.16 V
0-10 V	0.32 V
4-20 mA	1.60 mA

INPUT IMPEDANCE: Voltage ranges, greater than 300 kΩ; current ranges, 100 Ω

LOOP POWER: Two isolated power supplies, 24 VDC ± 5% @ 20 mA each, regulated. Maximum loop resistance is 1200 Ω

OPTIONAL POWER SUPPLY: 18 VDC (nominal) @ 200 mA (maximum) unregulated power supply can be provided instead of the two 24 VDC supplies.

LINEAR INPUT ACCURACY: ±0.05% of calibrated span, ±1 count.

ROOT EXTRACTION ACCURACY: ±0.1% F.S. ± 2 counts.

PROGRAMMABLE EXPONENT: From 1.0001 to 2.9999.

11 POINT LINEARIZATION:

Input Range	Minimum Span Between Inputs
4-20 mA	(1.6 mA / (Number of points -1))
0-5 V	(0.16 V / (Number of points -1))
0-10 V	(0.32 V / (Number of points -1))

e.g. Minimum span for an 11-point, 4-20 mA calibration is 0.16 mA between inputs.

ALARM POINTS: Four, any combination of high or low alarms.

ALARM POINT DEADBAND: 0-100% of full scale, user selectable.

ALARM STATUS INDICATION: Front panel LED.

PEAK HOLD (DISPLAY PEAK): Captures the peak process/rate and displays it via the front panel ENTER button (dSPY P).

PEAK HOLD INDICATION: Front panel flashing "R" LED.

LOCKOUT: Jumper JP1 labeled "LOCK" restricts modification of calibration values.

NON-VOLATILE MEMORY: All programming values are stored in non-volatile memory for a minimum of ten years if power is lost.

NORMAL MODE REJECTION: 64 db at 50/60 Hz.

POWER: AC power, 115 or 230 VAC (field select) ±10%, 50/60 Hz, 12 VA. DC Power, 22-28 VDC; 12 watts maximum.

ENVIRONMENTAL: Operating temperature range: -20 to +65°C. Storage temperature range: -40 to +85°C. Relative humidity: 0 to 90% non-condensing.

CONNECTIONS: Removable screw terminal blocks (provided), accept 22 to 12 AWG wire.

Rate/Totalizer/Batch Controller Features

RATE DISPLAY INDICATION: LED labeled "R" in lower right illuminates when meter is displaying rate, (or process input).

LOW-FLOW CUTOFF: Any input below the low-flow cutoff value will result in a display of zero. May be set from 1 count to 100% F.S., user selectable. To disable low-flow cutoff, program cutoff value to zero. Totalizer is based on rate display. So, inputs below the low-flow cutoff value will not affect the totalizer.

ALTERNATING DISPLAY: Display may be programmed to alternate between rate and total every 10 seconds.

TIME BASE: Second, minute, hour, or day

TOTAL DISPLAY: 0 to 999,999, automatic lead zero blanking.

TOTAL DECIMAL POINT: May be set in any of the following positions: 9.99999, 99.9999, 999.999, 9999.99, 99999.9. Total decimal point is independent of process/rate decimal point.

TOTAL CONVERSION FACTOR: Programmable from 0.00001 to 59999

TOTALIZER: Calculates total based on rate and field programmable multiplier to display total in any engineering unit.

TOTALIZER ROLLOVER: Totalizer "rolls over" when display exceeds 999,999. Relay status reflects display.

TOTALIZER PRESETS: Up to four, user selectable under Setup. Any set point can be assigned to total and may be programmed anywhere in the range of the meter. Relays assigned to total trip when total reaches the preset value and reset when total is reset to zero or when acknowledged manually. Can be programmed so when the highest preset value is reached the total automatically resets to zero.

PRESET OFFSET: Relays that are assigned to total can be programmed to trip at any point below the next relay's preset value. If preset offset mode is selected the corresponding relay will always trip at a programmed offset value before the next relay trips.

Example: Set Point 1 and 2 are setup for total, with Offset selected (under Set Point 2). If the preset offset is set at 10, (during Set Points programming for Set Point 1), then relay 1 will trip 10 counts before relay 2.

(Continue on back page)

SPECIFICATIONS (Continued from page 7)

PROGRAMMABLE DELAY ON RELEASE: If the meter is programmed to reset total to zero automatically when the highest preset is reached, then a delay will occur before the total relays reset. This delay can be programmed anywhere between 1 and 999 seconds

PRIORITY BATCH PROGRAMMING: This feature allows the user to quickly change preset values without going into the main menu by holding the ENTER button for more than 3 seconds.

TOTAL RESET: Via front panel ENTER button, external contact closure, or automatically via user selectable preset value.

TOTAL RESET LOCKOUT: Meter may be programmed so Total can not be reset from front panel.

Options

Relays

RATING: 2 or 4 SPDT (form C); rated 2 Amp @ 30 VDC or 2 Amp @ 250 VAC resistive load; 1/14 HP @ 125 / 250 VAC for inductive loads. Built-in suppression.

ASSIGN TO PROCESS/RATE OR TOTAL: Any relay may be assigned to process/rate or total.

BUILT-IN SUPPRESSION: Each relay contact is protected by a built-in suppressor (snubber) to prolong the life of the relays and provide a degree of protection against electrical noise caused by inductive loads. Suppressors value, .01 μ F/470 Ω , 250 VAC.

DEADBAND: 0-100% of full scale, user selectable.

HIGH OR LOW ALARM: User may program any alarm for a high or low trip point.

RELAY OPERATION: Latching or non-latching.

FAIL-SAFE OPERATION: Relay coils are energized in non-alarm condition. In case of power failure, relays will go to alarm state. Fail-safe operation may be disabled, by removing jumper J5 located on the Options PCB.

AUTO INITIALIZATION: When power is applied, relays assigned to total will reflect the state of the accumulated Total value in memory. Relays assigned to process/rate will reflect the state of the input to the meter.

TOTAL RELAYS RESET:

1. When total is reset to zero, if setup for external total reset.
2. After delay has elapsed, if setup for internal total reset.
3. Manual any time, if setup for external total reset. Manual reset resets all manually resettable relays.

PROCESS/RATE RELAYS RESET:

Relays assigned to process/rate may be programmed to reset in any of the following ways:

1. Automatic reset when the input passes the reset point.
2. Manual reset at any time (via user supplied external contact closure at terminals AK and CM or front panel ACK button.) Manual reset resets all manually resettable relays.
3. Automatic plus manual reset at any time. Relays will automatically reset when input passes the reset point. Relays can also be manually reset at any time (via user supplied external contact closure at terminals AK and CM or front panel ACK button.) Manual reset resets all manually resettable relays.
4. Manual reset only after alarm condition corrected. Relays can be manually reset only after alarm condition has been corrected (via user supplied external contact closure at terminals AK and CM or front panel ACK button.) Manual reset resets all manually resettable relays.

Isolated 4-20 mA Transmitter Output

CALIBRATION RANGE: The transmitter output can be calibrated so that a 4 mA output is produced for any process/rate measured by the meter. The 20 mA output may correspond to any process/rate that is at least 501 counts greater or smaller than the process/rate corresponding to 4 mA. (Ex. 4 mA = 0, 20 mA = 501) If the span between 4 and 20 mA is less than 501 counts, an error message will appear.

EQUIPMENT NEEDED: The 4-20 mA output is calibrated without the use of a calibrator.

OUTPUT LOOP-POWER: 24 VDC \pm 5% @ 20 mA, regulated. Maximum loop resistance is 1200 Ω . Isolated from input loop-power.

ACCURACY: \pm 0.1% F.S., \pm 0.004 mA.

ISOLATION: 500 VDC or peak AC, input-to-output or input/output-to-power line.

EXTERNAL LOOP-POWER SUPPLY: 35 VDC maximum

OUTPUT LOOP RESISTANCE:

Power supply	Min. loop resistance	Max. loop resistance
24 VDC	10 Ω	600 Ω
35 VDC (external)	600 Ω	1000 Ω

DISCLAIMER: The information contained in this document is subject to change without notice. Precision Digital makes no representations or warranties with respect to the contents hereof, and specifically disclaims any implied warranties of merchantability or fitness for a particular purpose.

YOUR LOCAL DISTRIBUTOR IS:

WARRANTY: One year parts and labor.

EXTENDED WARRANTY: Warranty may be extended for an additional 12 months by returning the Product Registration Form within 2 months from date of purchase. For online registration please go to www.predig.com.

Please visit the Precision Digital website at www.predig.com for complete information on the entire line of Precision Digital products, technical information and much more.

LDS650-6 Rev B 06/01