

PROCESS & TEMPERATURE CONTROLLERS

NOVA PD540 Series



- Thermocouple, RTD, & Process Inputs
- High Accuracy Auto-Tuning PID
- Heating & Cooling Models
- Universal Power Supply 100-240 VAC
- Up to 3 Relays & 2 Analog Outputs
- Digital Input Set Point Selection
- RS-485 Serial Communication Option
- Modbus® RTU/ASCII Communications
- Free Operating & Data Logging Software
- IP55 & IP65 Fronts
- 1/16, 3/16, 1/8, 1/4 DIN Sizes
- 3 Year Warranty

PRECISION DIGITAL CORPORATION

PRECISION
DIGITAL

www.predig.com

CUSTOM OPERATING DISPLAYS

The Nova Digital Controller has dual four-digit LEDs and can display commonly used setup parameters defined by the user.

Operating Display Navigation

To access additional display information without the need to enter the setup menus, simply press the SET/ENT button.

Main Operating Display

- PV window displays process variable
- SP window displays set point
- Press the SET/ENT button to move to the next display window



Percent Output Display

- PV window displays process variable
- SP window displays the operating level of the control outputs as % of full scale
- Press the SET/ENT button to move to the next display window

User Defined Display 1

- Display any setup parameter
- Parameters are fully functional, and can be set through this display
- Set by the user with parameter *US1*
- Press the SET/ENT button to move to the next display window



User Defined Display 2

- Display any setup parameter
- Parameters are fully functional, and can be set through this display
- Set by the user with parameter *US2*
- Press the SET/ENT button to return to the main operating display



EASY SETUP & PROGRAMMING

All programming of a Nova Digital Controller is done through the front panel. No switches or jumpers are required.

Front Panel Buttons

- Press the SET/ENT button to confirm an entered value. Hold the button for 3 seconds to enter or exit the setup groups. Press the SET/ENT button to access the next parameter when in a setup group.
- Press the Up arrow button to increase numerical values or scroll through parameter options and group menus.
- Press the Down arrow button to decrease numerical values or scroll through parameter options and group menus.
- Press the LEFT arrow button to move to the next digit during numerical value programming.

Setup Group Menus

For easy setup parameter navigation, all parameters are grouped by category. To access the group menus, press and hold the SET/ENT button for 3 seconds. Navigate through the group menus using the UP or DOWN arrow buttons as shown. To enter a group menu to access setup parameters, press the SET/ENT button.

Button	PV Display	Group Definition
▼	G.AE	Auto-Tuning Group
▲▼	G.SP	Set Point Group
▲▼	G.P Id	P.I.D. Group
ENT	P.yd	Password
▲▼	G.CtL	Control Group
▲▼	G.In	Input Group
▲▼	G.oUt	Output Group
▲▼	G.ALn	Alarm Group
▲▼	G.rEt	Retransmission Group
▲▼	G.Coñ*	Communication Group*

*This group menu appears only on models with the serial communication option.

Menu Password

To prevent unauthorized changes to key parameters, a user defined lockout password must be entered to access the group menus that are not commonly used during operation. Enter the password at the prompt when navigating the group menus by pressing the SET/ENT button. The default password is 0.

Easy to Use Menu Structure

Each parameter is located in an associated menu group.

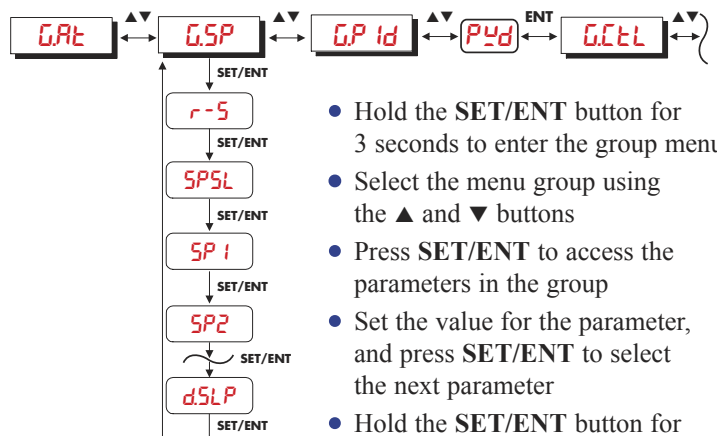

- Hold the SET/ENT button for 3 seconds to enter the group menu
- Select the menu group using the ▲ and ▼ buttons
- Press SET/ENT to access the parameters in the group
- Set the value for the parameter, and press SET/ENT to select the next parameter
- Hold the SET/ENT button for 3 seconds to return to the operating display

For a complete list of setup parameters, their functions, and setting options, refer to the PD540 Series Instruction Manual.

PROCESS & TEMPERATURE INPUTS

Nova Controllers use a single universal input that accepts process and temperature inputs.

Thermocouple: J, K, T, E, R, B, S, L, N, U, W, Platinel II

RTD: Pt100 (0.00385), JPt100 (0.00392)

Process: -10 to 20 mV, 0 to 100 mV
0.4 to 2 V, 1 to 5 V, 0 to 10 V
4 to 20 mA input with a resistor shunt

VERSATILE OPERATION

Powerful standard and optional features such as universal inputs, up to three relays and two analog outputs, digital inputs, and serial communications make the controller applicable for most process or temperature control applications.

Programmable Relays

All PD540 Series controllers have a standard 3 A Form C (SPDT) relay. Up to two additional 1 A Form A (SPST) relays may be added. All relays can be programmed for numerous control or alarm functions.

- Time-Proportional PID Control
- On/Off Control
- High/Low Alarms
- Set Point Deviation Alarms
- Fail-Safe and Standby Alarms
- Alarm Delays and Deadbands

Analog Output Configurations

Up to two analog outputs are available on all PD540 Series controllers. Each analog output can be programmed independently, and numerous output types are selectable.

- 4-20 mA PID Control
- 4-20 mA Retransmitting
- Time-Proportional PID Voltage Pulse

Auto-Tuning PID

A high accuracy auto-tuning function using Fuzzy Logic calculates the PID values for your system with the push of a button, eliminating the need for complex PID calculations and time consuming setup. After several on/off cycles, the PID values will be setup automatically.

Gain Adjustment

Through the use of a user programmable Gain parameter, adjustments to system control characteristics can be done easily. Increasing the Gain will increase accuracy and reduce overshoot. Lowering the Gain will let the system reach the set point faster.

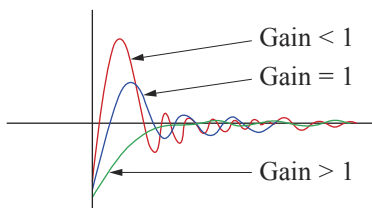

PV Reactions to SP Change Based on Gain

Input Bias Adjustment

Up to five bias points can be used to provide precise offset adjustments at specific input values. The controller will use the offset to create a smooth input value curve leading up to the bias points.

On/Off Timers

The start timer delays control output operation from power-up. The process timer determines how long the outputs will run after starting. These timers may run up to 99 hours 59 minutes, or be turned off.

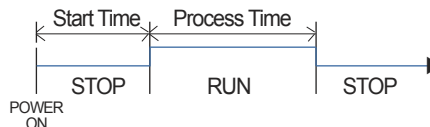

Digital Input Set Point Selection

Two digital inputs can be added as an optional feature. Digital inputs are activated by closing contacts on the back of the meter with a switch or relay. The configuration of the two inputs can select which of the 4 programmable set points to run or turn the control outputs on and off while selecting one of two programmable set points.

DI Selection	Input 1	Input 2	Function
1	off	–	STOP
	on	–	RUN
	–	off	SP1
	–	on	SP2
2	off	off	SP1
	on	off	SP2
	off	on	SP3
	on	on	SP4

Normally open switches (external excitation not required) or open collector transistor

Serial Communication & Adapters

Nova controllers with the serial communication option can be used for data acquisition, master/slave set point control, or Modbus communication (RTU and ASCII). The Nova controllers transmit via RS-485. RS-485/RS-232 and USB/RS-485 converters are available for use with the Nova Multi-Monitoring software or other PC applications.



PDA7487



PDA7485



PDA7486

Sync Master/Slave Set Point Control

PD540 Series Digital Controllers with the serial communication option can use Sync set point control. By connecting controllers together using the RS-485 serial communication capability, one controller can control the set point of an entire string.

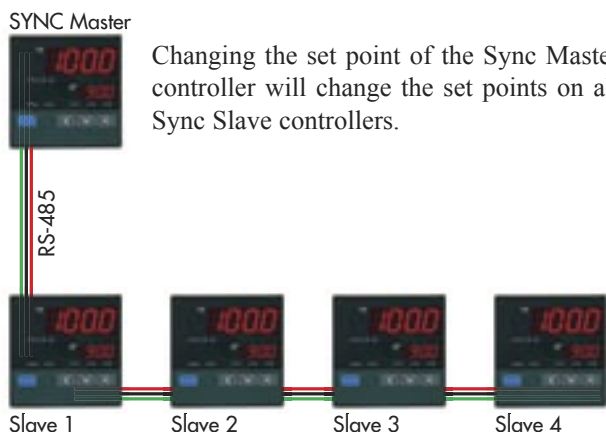

Simultaneously View Up to 30 Nova Controllers

NOVA PC SOFTWARE

Any Nova Controller with the serial communication option can be configured to interface with the Nova Multi-Monitoring PC software. Up to 30 controllers can be monitored and operated, and each can use independent data logging.

- Easy to Set Up and Use
- Connect up to 30 Nova Controllers
- View PV, SP, and Alarm Status Simultaneously
- Control Set Points
- Log, View, and Save Data in Spreadsheet Files
- Free Download from www.predig.com

Specifications

System Requirements: Windows® 95\98\ME\2000\XP

Communications: An RS-485/RS-232 or USB/RS-485 converter may be used for communication with a PC and Nova Multi-Monitoring Software.

Number of Units: Up to 30 Nova Controllers

Baud Rate: 9600 bps to 19.2 kbps

Data Logging: Graph and save data as .hdr format. Each controller saves graphs independently. Data exportable in spreadsheet format.

Logging Interval: 1 second to 24 hours

Simultaneous Monitoring

Simultaneously monitor up to 30 Nova Controllers and view the PV, SP, and alarm status for all connected controllers. The main view screen also displays the basic model numbers of all connected units. Any series of Nova Controllers with the serial communication option may be monitored with this software.

Remotely Control Set Points

Program each of the 4 set points through a detailed operation screen available for every connected controller. In addition, control outputs can be set to run or stop, auto tuning enabled, and manual/auto control established.



Monitor and Control Common Parameters

Data Acquisition

PV and SP data can be logged independently for each unit. This data can be graphed using the Data Viewer for quick and clear analysis. Logged data can be exported into spreadsheet format.

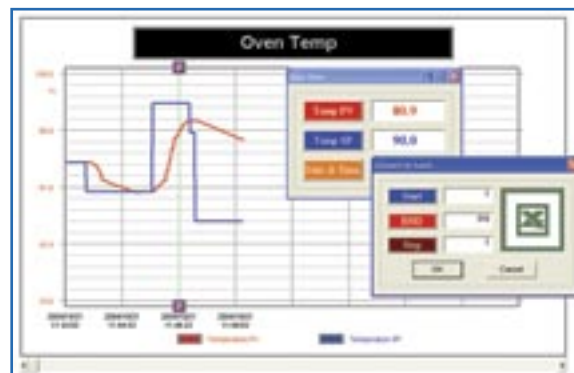

View Logged Data Graphs and Export Data

CONNECTIONS DIAGRAM

PD540 & PD541

: Options

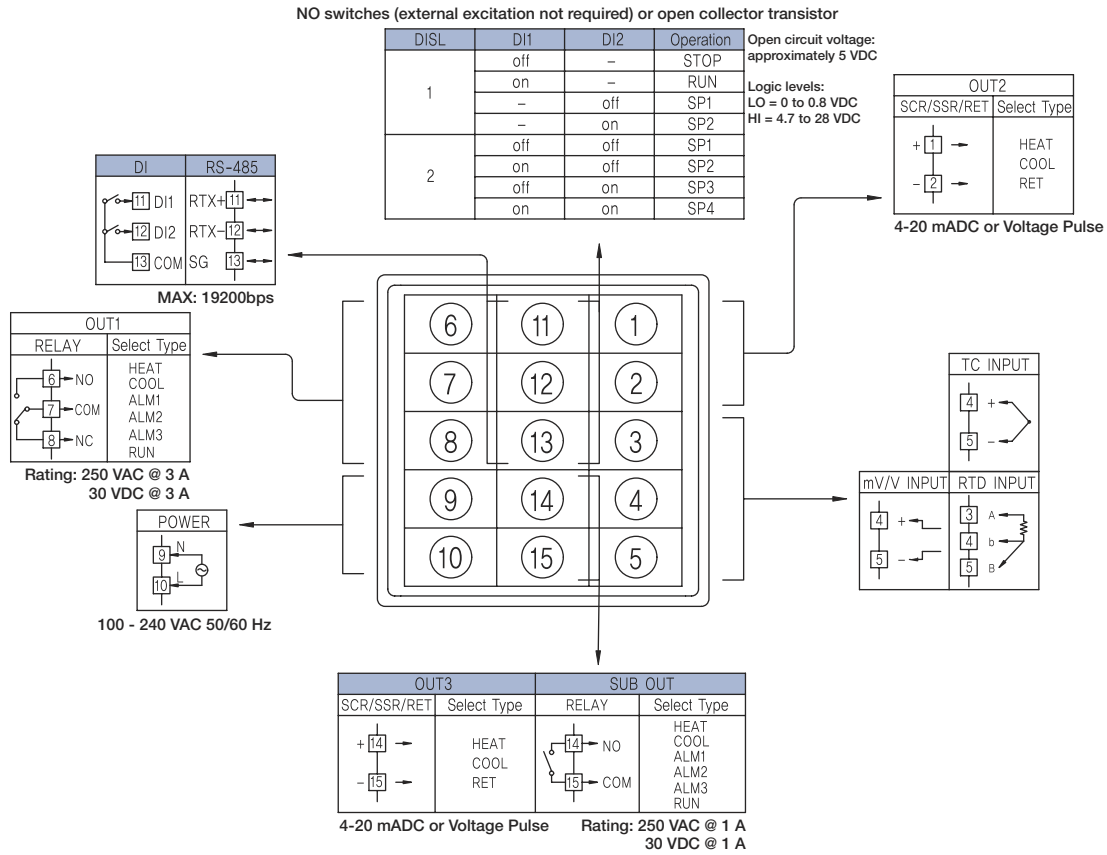

PD542 & PD543

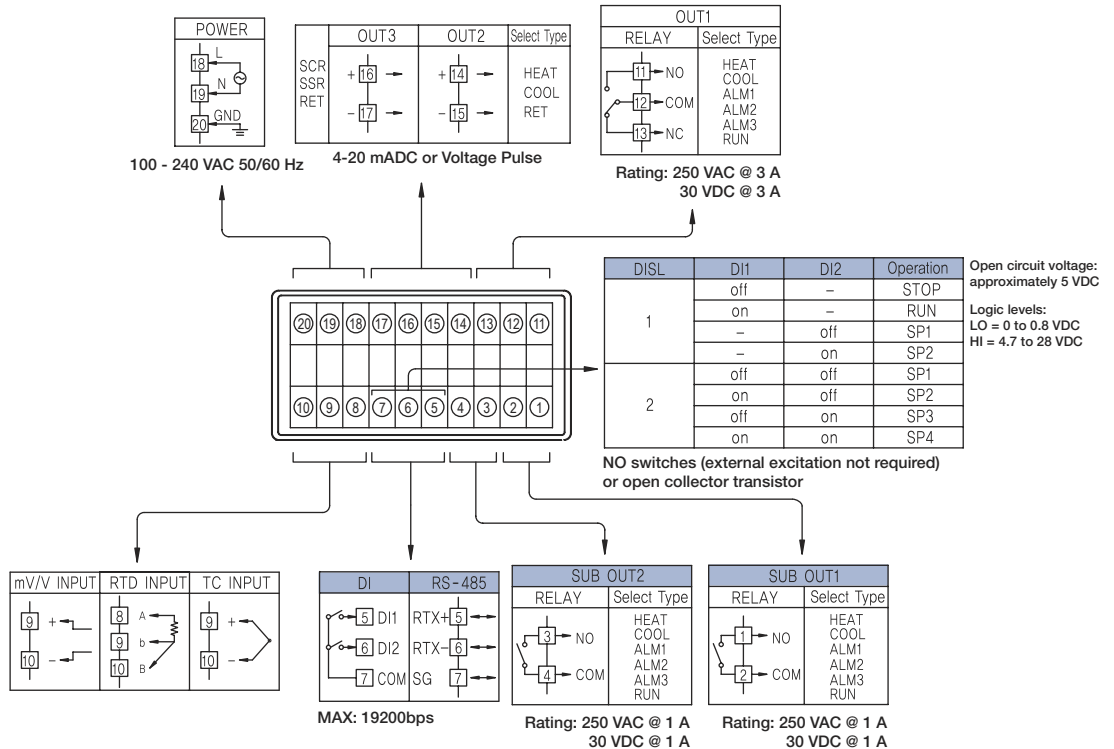

CONNECTIONS DIAGRAM

PD544 & PD545

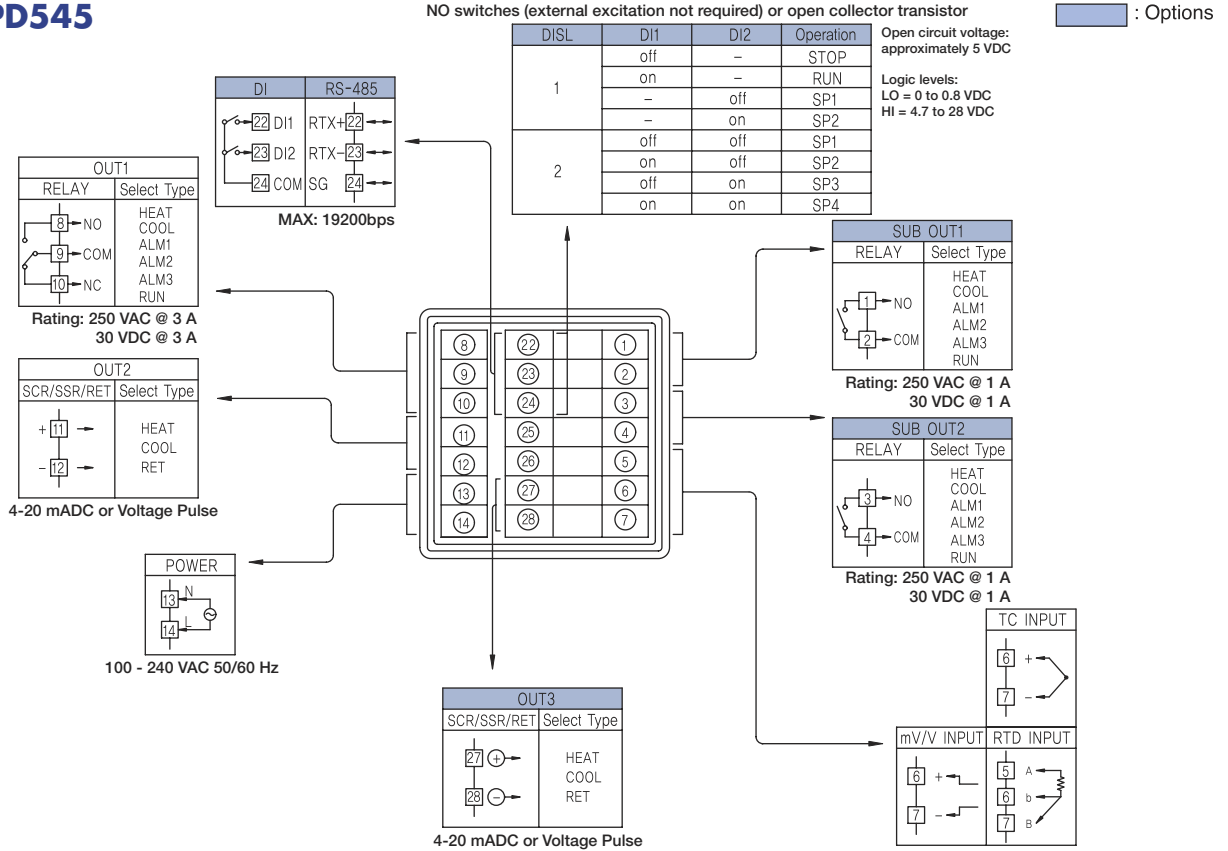

PD546 & PD547

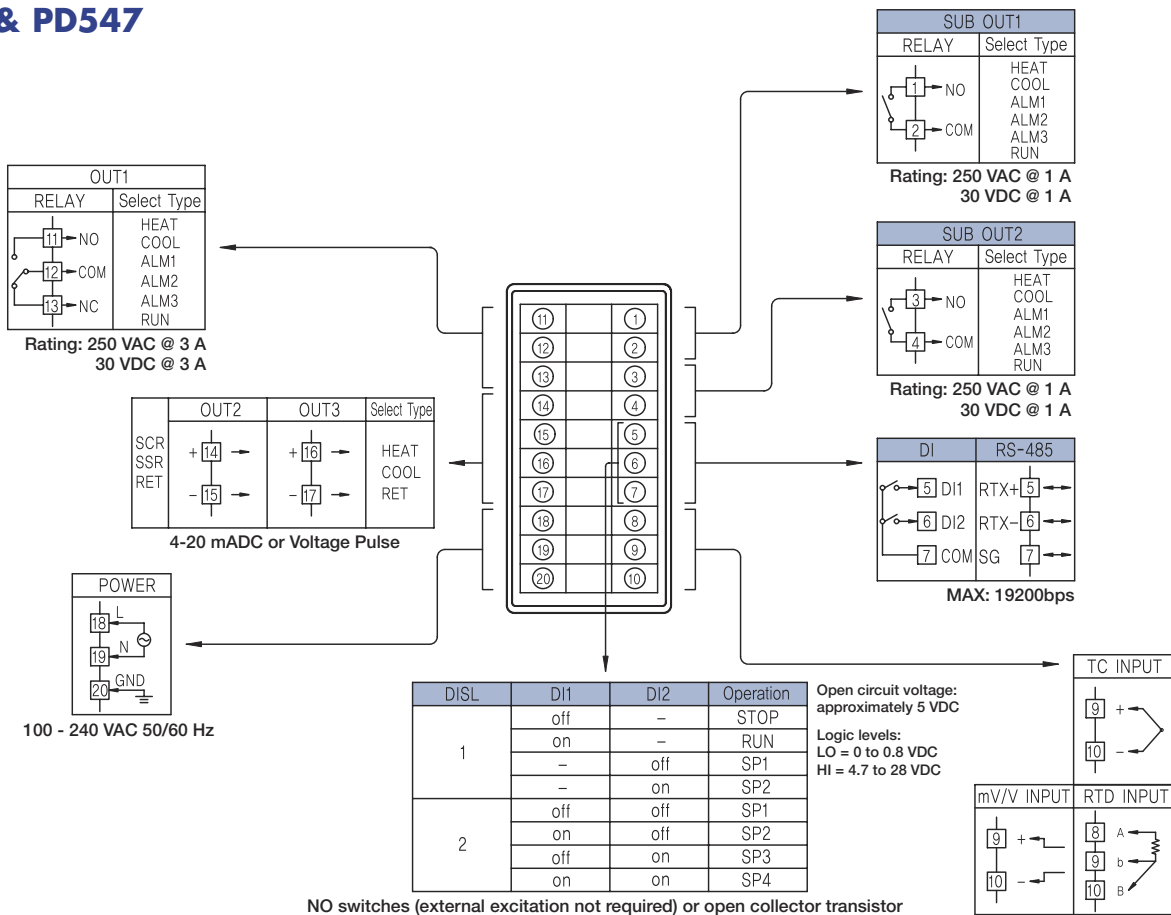

CONNECTIONS DIAGRAM

PD548 & PD549

 : Options

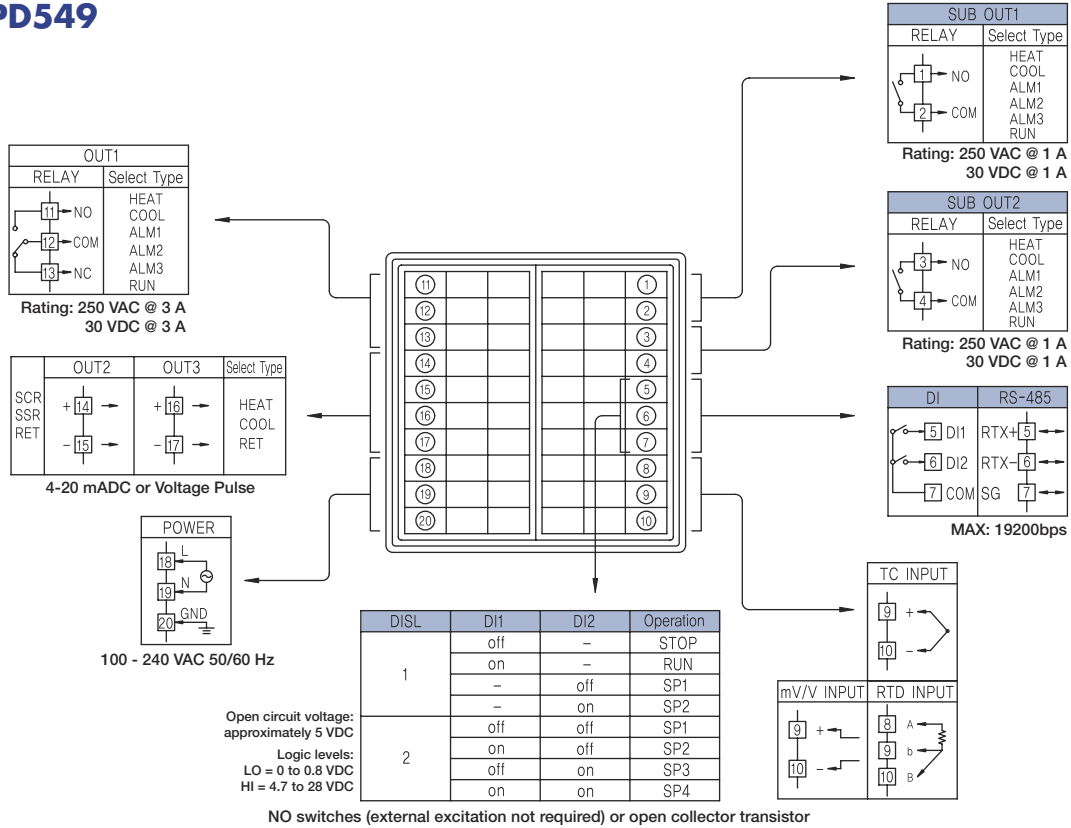

MODEL NUMBER GUIDE

The following guide describes the possible PD540 Series Nova Digital Process & Temperature Controller model numbers. For a complete list of available models, see the Nova Price List, available online at www.predig.com.

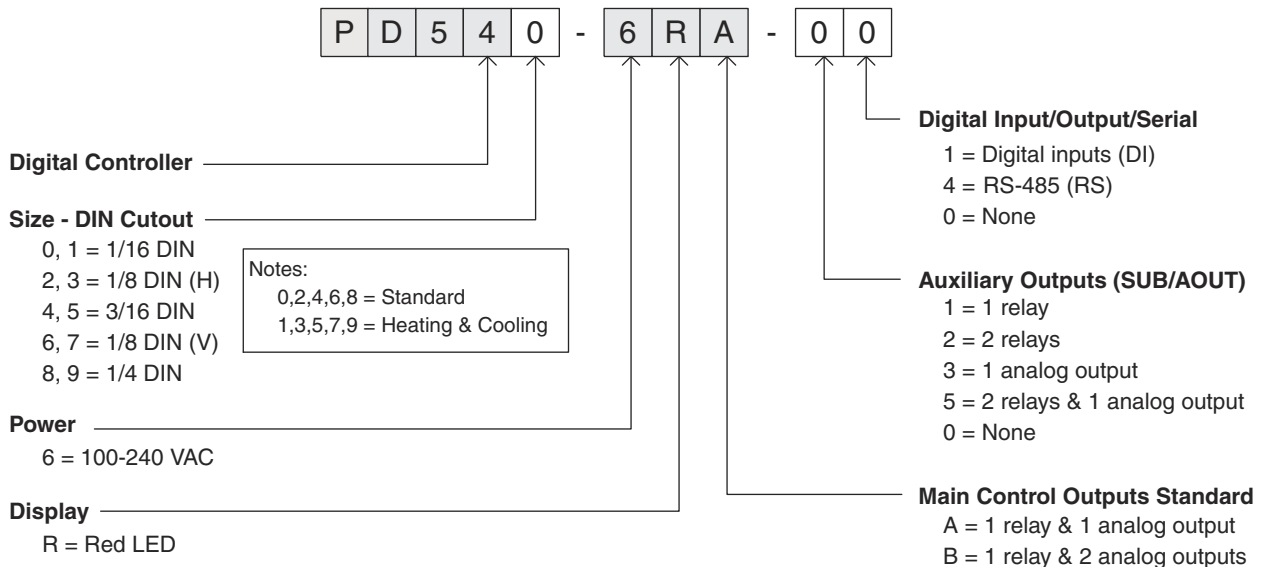

DIMENSIONS AND PANEL CUTOUTS

**Units: inches
(mm)**

PD540 & PD541

1/16 DIN

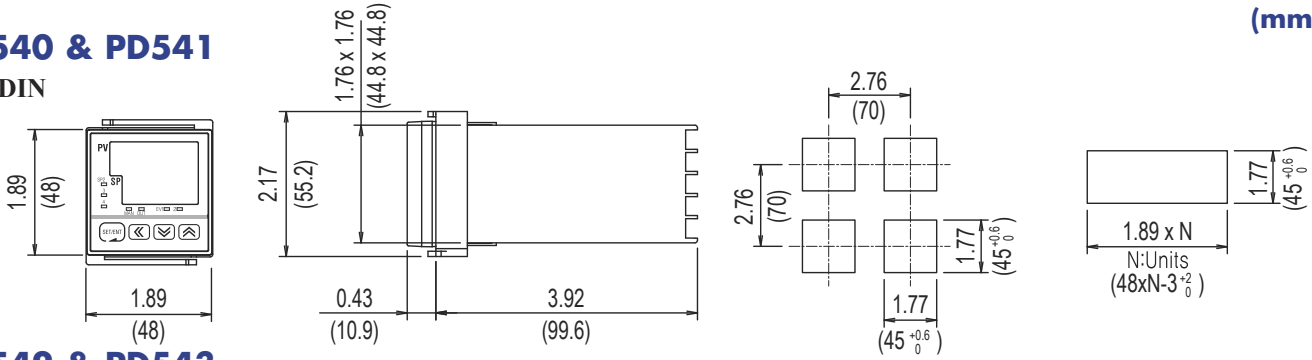

PD542 & PD543

1/8 DIN (H)

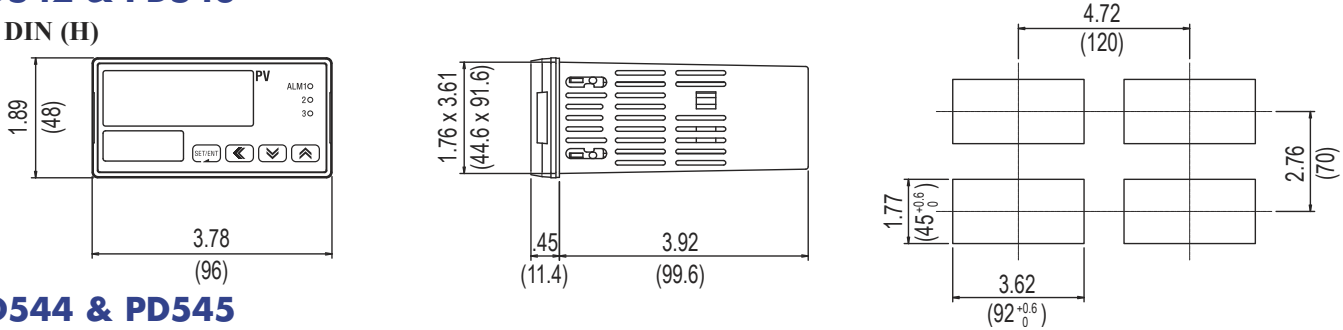

PD544 & PD545

3/16 DIN

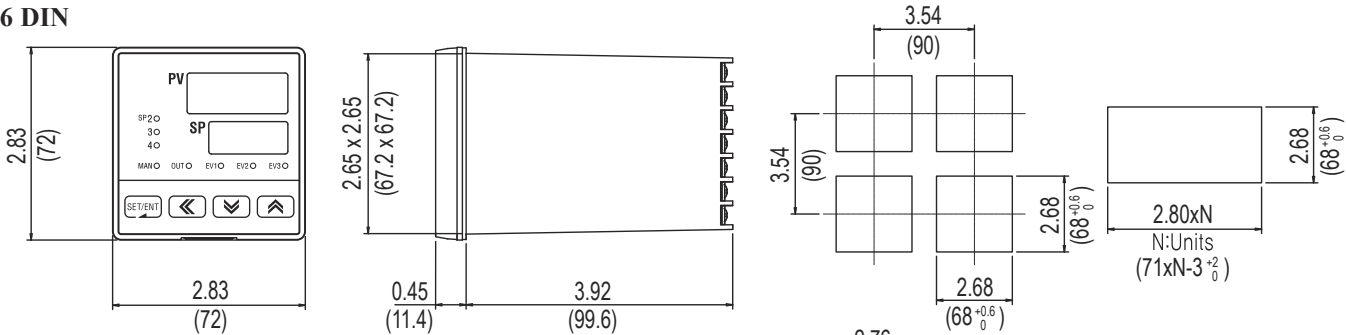

PD546 & PD547

1/8 DIN (V)

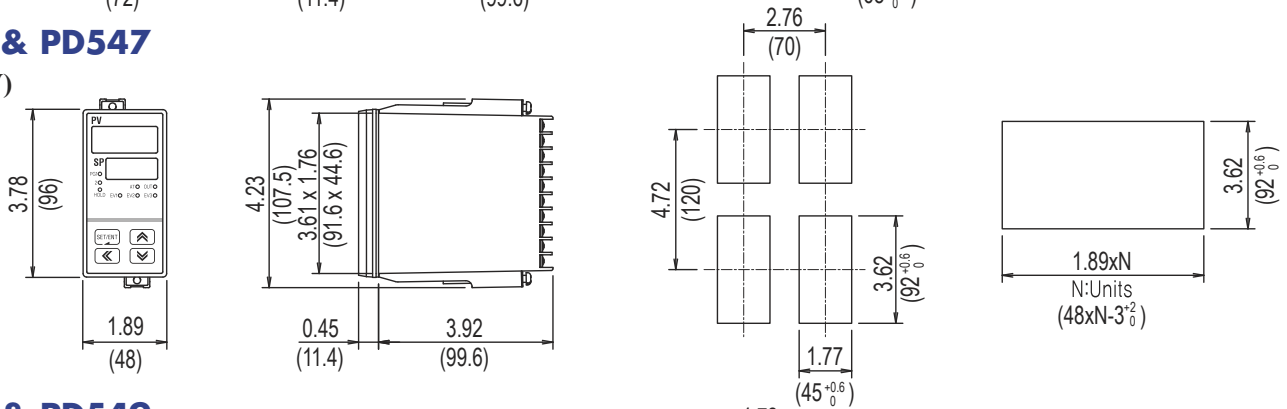

PD548 & PD549

1/4 DIN

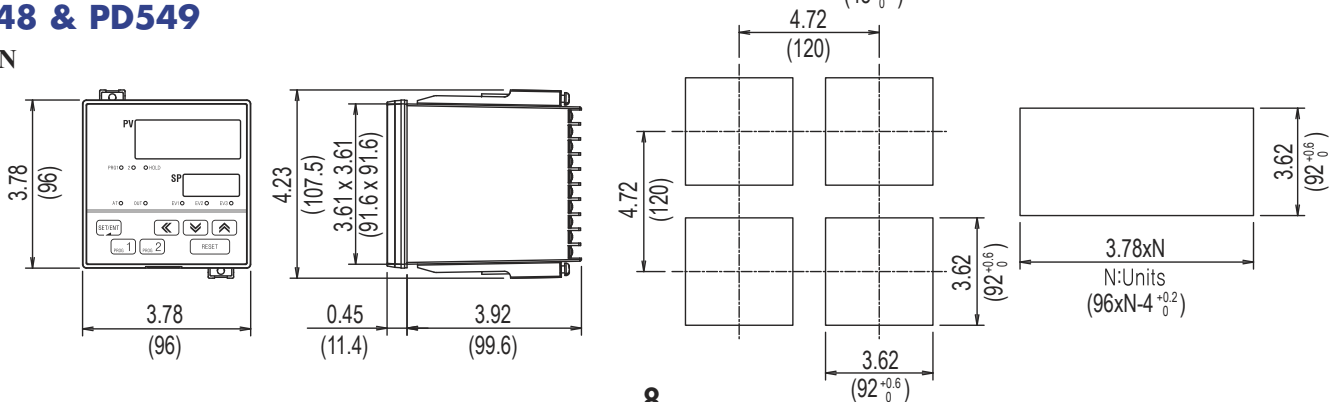

SPECIFICATIONS

Except where noted all specifications apply to operation at +25°C.

General

Display: Dual 4 digits, red LED, -1999 to 9999

DIN Sizes	PV Display	SP Display
1/16	0.45" (11.3 mm)	0.37" (9.5 mm)
3/16	0.55" (14.0 mm)	0.47" (12.0 mm)
1/8 (H)	0.78" (19.8 mm)	0.45" (11.5 mm)
1/8 (V)	0.54" (13.6 mm)	0.41" (10.5 mm)
1/4	0.81" (20.5 mm)	0.43" (11.0 mm)

Front Panel: Panel gasket provided

1/16 & 1/8 DIN: IP65

3/16 & 1/4 DIN: IP55

Programming Methods: Four front panel buttons and Modbus

Number of Set Points: Four programmable set points

Noise Filter: Programmable 1 to 120 seconds, or off

Display Update Rate: 4/second

Non-Volatile Memory: All programmed settings are stored in non-volatile memory if power is lost.

Power: 100-240 VAC, 50/60 Hz, 10 watts

Required Fuse: UL Recognized, 1 A, 250 V, slow-blow

Isolation: 500 V input-to-output-to-power line; 4 kV relay output-to-input/output/power line.

Operating Temperature: 10 to 50°C

Storage Temperature: -40 to 85°C

Relative Humidity: 20 to 90% non-condensing

Enclosure: 1/16, 3/16, 1/8(H), 1/8(V), 1/4 DIN; color: black

UL File Number: E244207; Process Control Equipment

Warranty: 3 year parts & labor

Extended Warranty: 1 or 2 years, refer to Price List for details

Temperature Inputs

Inputs: Factory calibrated, field selectable: J, K, T, E, B, R, S, L, U, N, W, Platinel II thermocouples, and 100 Ω platinum RTD (0.00385 or 0.00392 curve)

Cold Junction Reference: Automatic or off

Offset Adjustment: Four programmable input bias zones

Sensor Break: Up or down scale, user selectable; display reads S.OPN; alarm relays will follow the up or down scale selection

Type	Range (°C)	Range (°F)	Accuracy*	
Thermocouple	K1	-200° to 1370°C	-300° to 2500°F	>0°C: ±0.1% FS ±1 count <0°C: ±0.2% FS ±1 count
	K2	-199.9° to 999.9°C	0° to 2300°F	
	J	-199.9° to 999.9°C	-300° to 2300°F	
	T	-199.9° to 400.0°C	-300° to 750°F	
	E	-199.9° to 999.9°C	-300° to 1800°F	
	B	0° to 1800°C	32° to 3300°F	>400°C: ±0.15% FS ±1 count <400°C: ±5% FS ±1 count
	R	0° to 1700°C	32° to 3100°F	±0.15% FS ±1 count
	S	0° to 1700°C	32° to 3100°F	
	L	-199.9° to 900.0°C	-300° to 1600°F	>0°C: ±0.1% FS ±1 count <0°C: ±0.2% FS ±1 count
	U	-199.9° to 400.0°C	-300° to 750°F	>0°C: ±0.1% FS ±1 count <0°C: ±0.25% FS ±1 count
	N	-200° to 1300°C	-300° to 2400°F	
	W	0° to 2300°C	32° to 4200°F	±0.2% FS ±1 count
Platinel II	0° to 1390°C	32° to 2500°F	±0.1% FS ±1 count	
RTD	PtA	-199.9° to 850.0°C	-300° to 1560°F	±0.1% FS ±1 count
	PtB	-199.9° to 500.0°C	-199.9° to 999.9°F	
	PtC	-19.99° to 99.99°C	-4.0° to 212.0°F	±0.2% FS ±1 count
	JPTA	-199.9° to 500.0°C	-199.9° to 999.9°F	±0.1% FS ±1 count
	JPTB	-150.0° to 150.0°C	-199.9° to 300.0°F	

*Performance within recommended operating conditions (10 to 50 °C, 20 to 90% RH)

Process Inputs

Inputs: Field selectable: 0.4 to 2.0 V, 1 to 5 V, 0 to 10 V, -10 to 20 mV, 0 to 100 mV. 4-20 mA input with 100 Ω resistor.

Accuracy: ±0.1% FS ±1 count

Decimal Point: Up to 3 decimals: 9.999, 99.99, 999.9, or 9999

Calibration: All inputs are calibrated at the factory

Scale Range: User programmable over entire range

Relays

Ratings: 1 Form C (SPDT) standard, rated 3 A @ 30 VDC or 3 A @ 250 VAC resistive load. Up to 2 Form A (SPST), rated 1 A @ 30 VDC or 1 A @ 250 VAC resistive load.

Relay Operation: Time proportional PID control, on/off control, forward or reverse (fail-safe) alarm, or run status

Cycle Time: 1 to 300 seconds; time-proportional PID control only

On/Off Hysteresis: For standard models, 0-10.0% of sensor range for independent high and low hysteresis limit. For heating & cooling models, 0-10.0% of sensor range full hysteresis band.

High/Low Alarm: User may program any alarm for absolute high or low trigger values.

Deviation Alarm: User may program any relay for high, low, or high/low range set point deviation alarm.

Alarm Deadband: 0-100% FS, user selectable

Alarm Delay: 0 to 99 minutes and 59 seconds

Reverse Operation (Fail-Safe): Programmable, independent for each alarm.

Relay coils are energized in non-alarm condition. In case of power failure, relays will go to alarm state.

Forward Operation: Relay coils are energized in alarm condition. In case of power failure, relays will go to non-alarm state.

Auto Alarm Initialization: Normal and standby operation independent for each alarm. Normal alarms will reflect the state of the input to the controller at all times. Standby alarms will not trigger if the change to alarm state is a result of power up cycle, set point change, or alarm configuration change.

Run Status: Relays will energize when PID outputs are running

Analog Outputs

Scaling Range: Retransmitting 4-20 mA outputs can be scaled for any display

Accuracy: ±0.1% FS

Availability: 1/16 & 3/16 DIN: 1 standard, 1 optional
1/8 & 1/4 DIN: 2 standard

Output Operation: 4-20 mA PID control, time-proportional voltage pulse PID control, or 4-20 mA retransmitting

Ratings: Continuous 4-20 mA PID or retransmitting: 600 Ω max
Time Proportional PID: 15 VDC pulse high, less than 0.1 VDC pulse low; 600 Ω minimum, current limited at 30 mA

Cycle Time: 1 to 300 seconds; time-proportional PID control only

Power: Internally powered 4-20 mA output

Isolation: 500 V input-to-output-to-power line; 4 kV relay output-to-input/output/power line.

Output Loop Resistance: 600 Ω max

Digital Inputs

Configuration: Two contacts, two operating modes

Contacts: Normally open switches (external excitation not required) or open collector transistor

Open Circuit Voltage: Approximately 5 VDC

Logic Levels: LO = 0 to 0.8 VDC, HI = 4.7 to 28 VDC

Operation Modes: Mode 1: Control output run or stop, selection of set point 1 or 2. Mode 2: Selection of set points 1 to 4

Serial Communications

Protocols: PC, Modbus (ASCII, RTU), Sync (Master/Slave SP Control)

Address: 1 to 99 (Max 31 units connected)

Baud Rate: 600 to 19,200 bps, user selectable

Transmit Time Delay: 0 to 100 ms

Data: 7 or 8 bit, automatic when using Modbus protocol

Stop Bit: 1 or 2

Parity: None, even, or odd



LDS540_A
02/05