

# TEMPERATURE MONITOR

WITH ANALOG AND HIGH / LOW ALARMS OUTPUTS.



## Features

- Displays actual temperature and alarm values.
- 4 alarm values can be entered: low-low, low, high and high-high temperature alarm.
- Large 17mm (0.67") digits.
- Selectable on-screen engineering units °C - °F - K
- Operational temperature -30°C up to +80°C (-22°F up to 178°F).
- Very compact design for panel mount, wall mount or field mount applications.
- Rugged aluminum field mount enclosure IP67 / NEMA4X.
- Intrinsically safe  $\text{Ex}$  II 1GD EEx ia IIB/IIC T4 T100°C.
- Explosion/flame proof  $\text{Ex}$  II 2G EEx d IIB T5.
- Alarm and analog signal outputs.
- Full Modbus communication RS232/485/TTL.
- Loop or battery powered, 8 - 24V AC/DC or 115 - 230V AC power supply.
- Sensor supply 3.2 - 8.2 - 12 - 24V DC.

## Signal output

- Up to 4 free configurable alarm outputs.
- (0)4 - 20mA / 0 - 10V DC according to the temperature.

## Signal input

### Temperature

- PT100 - 2 or 3 wire.
- (0)4 - 20mA.
- 0 - 10V DC.

## Applications

- For applications where continuous temperature measurement and monitoring is important. Also re-transmission of the actual temperature or serial communication is required. Alternative basic model: F040 - F043.

## General information

### Introduction

The F143 is a versatile temperature indicator with continuous temperature monitoring feature. It offers the facility to set two low temperature and two high temperature alarm values.

If desired, an ignore function can be set up to allow for an incorrect temperature for a certain period of time. Up to four outputs are available to transmit the alarm condition.

A wide selection of options further enhance this model's capabilities, including intrinsic safety and full Modbus communication.

### Display

The display has large 17mm (0.67") and 8mm (0.31") digits which display the temperature, measuring unit and alarm values. The alarm values can be password protected. On-screen engineering units are easily configured from a comprehensive selection.

### Configuration

All configuration settings are accessed via a simple operator menu which can be pass-code protected. Each setting is clearly indicated with an alphanumeric description, therefore avoiding confusing abbreviations. All settings are safely stored in EEPROM memory in the event of sudden power failure.

### Analog output signal

The actual temperature is re-transmitted with the (0)4 - 20mA or 0 - 10V DC output signal. The output signal is updated ten times per second with a filter function being available to smoothen out the signal if desired. The output value is user defined in relation to the temperature, e.g. 4mA equals to -20°C and 20mA equals to 250 °C. The output signal can be passive, active or isolated where the passive output type will loop power the F143 as well.

### Alarm output

Up to four configurable outputs are available to transmit the alarm condition. You can have e.g. two the same low alarm outputs, one high alarm output and one "all alarms" output. Type OS offers four mechanic relay outputs. However, only two outputs are available in Intrinsically Safe applications. Three outputs are

available in all other configurations. The output signals can be a passive NPN, active PNP or an isolated electro-mechanical relay.

### Signal input

The F143 does accept (0)4 - 20mA and 0 - 10V input signals from any type of temperature measurement device. Also a two or three wire PT100 sensor can be used.

### Communication

All process data and settings can be read and modified manually or through the Modbus communication link (RS232 / RS485). Full Modbus functionality remains available for the Intrinsically Safe version (TTL).

### Hazardous areas

For hazardous area applications, this model has been ATEX certified intrinsically safe  $\text{Ex}$  II 1GD EEx ia IIB / IIC T4 T100°C with an allowed operational temperature of -30°C to +70°C (-22°F to +158°F). A flame proof enclosure is also available with the rating  $\text{Ex}$  II 2G EEx d IIB T5.

### Enclosures

Various types of enclosures can be selected, all ATEX approved. As standard the F143 is supplied in an ABS panel mount enclosure, which can be converted to an IP67 / NEMA 4X ABS field mount enclosure by the addition of a back case. Most popular is our rugged aluminum field mount enclosure with IP67 / NEMA 4X rating. Both European or U.S. cable gland entry threads are available.

## Overview application F143

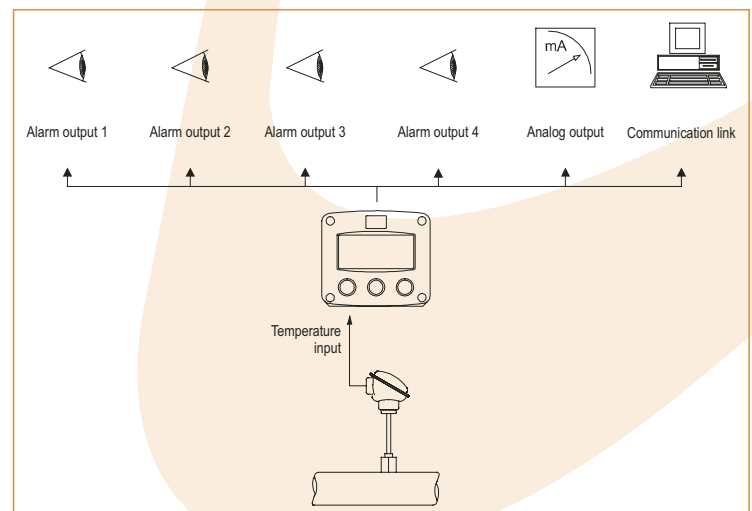

## Dimensions enclosures

### Enclosure HA

#### Aluminum field mount enclosure

IP67 / NEMA 4X  
Tapped holes: European thread

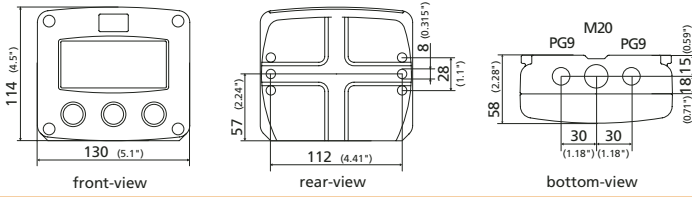

### Enclosure HB

#### Aluminum panel mount enclosure

IP65 / NEMA 4

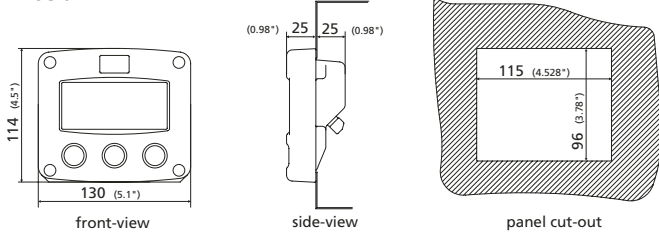

### ENCLOSURE HC (STANDARD)

#### ABS PANEL MOUNT ENCLOSURE

IP65 / NEMA 4

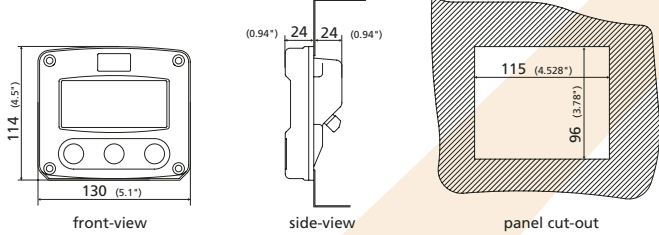

### Enclosure HD

#### ABS wall mount enclosure

IP67 / NEMA 4X  
Holes user defined

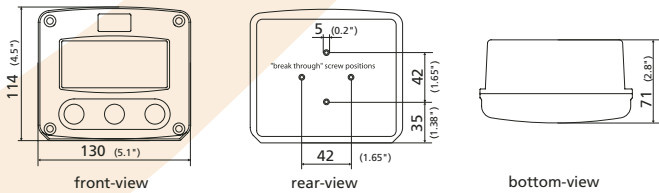

### Enclosure HU

#### Aluminum field mount enclosure

IP67 / NEMA 4X  
Tapped holes: U.S. thread

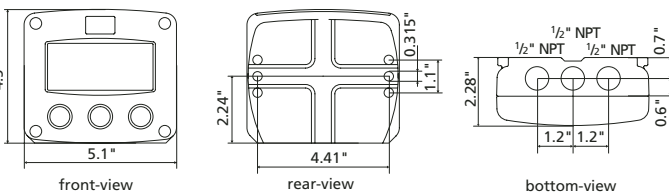

## Terminal connections

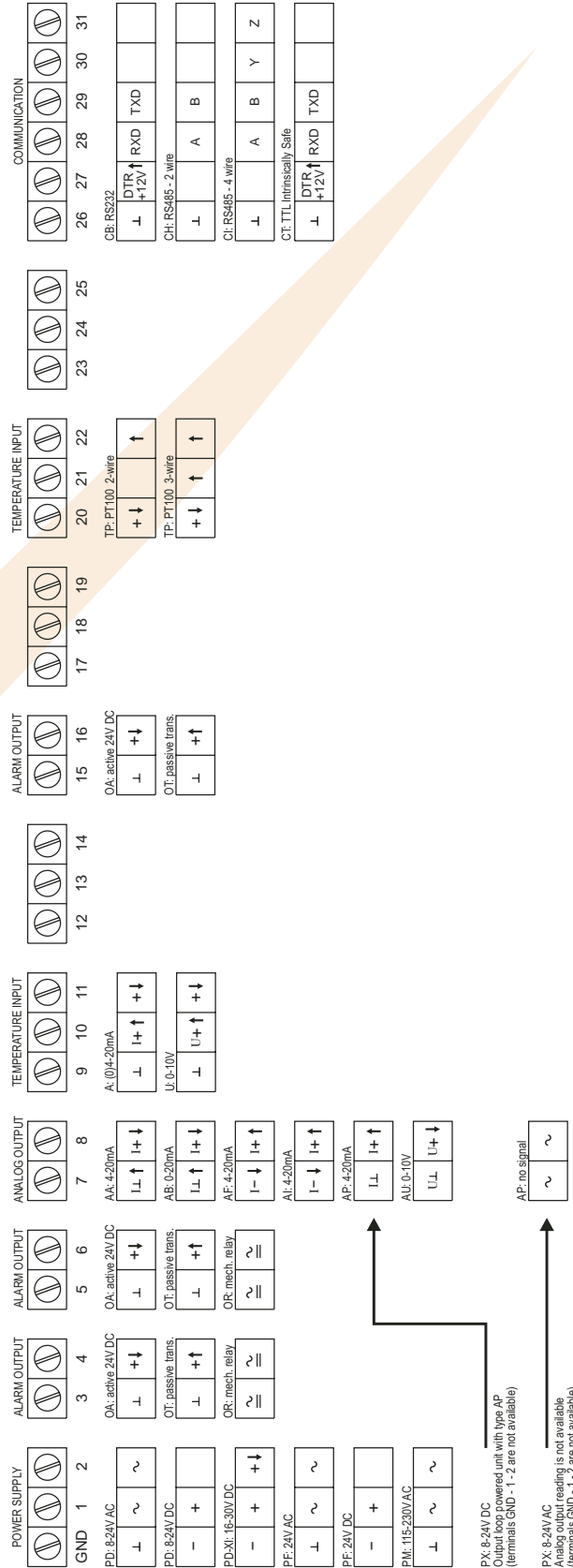

Please note:  
Terminal connections for the F143 with four alarm outputs (type OS) is shown on one of the next pages.

Typical wiring diagram F143-T-AP-CH-OT

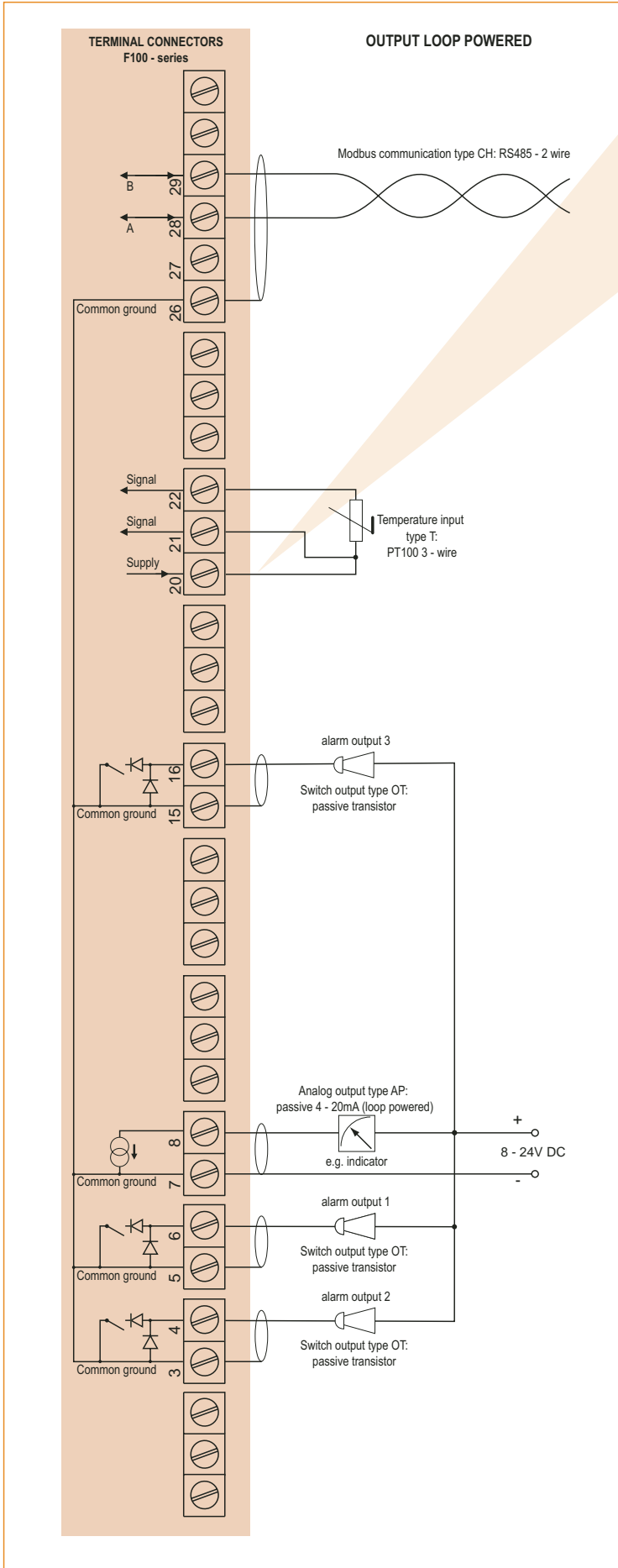

Typical wiring diagram F143-A-AA-CB-OA-PD

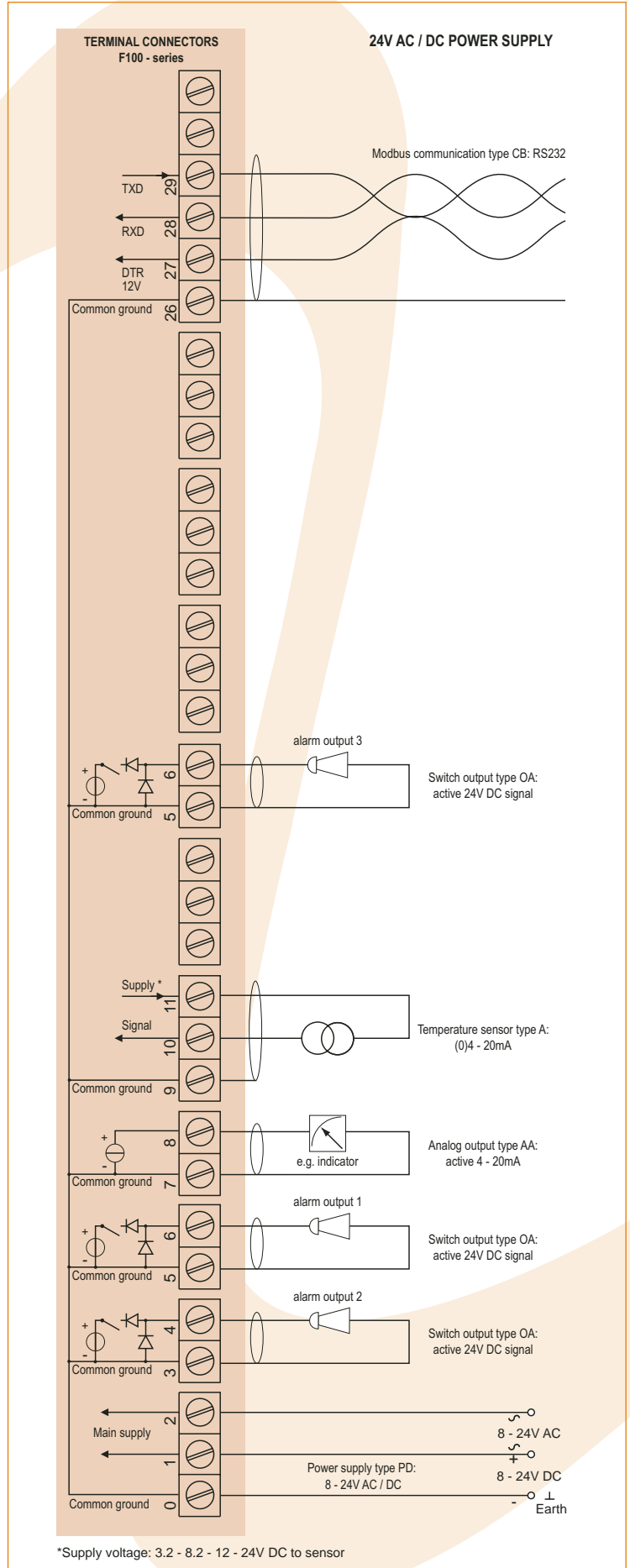

Typical wiring diagram F143-A-AI-CI-OR-PM

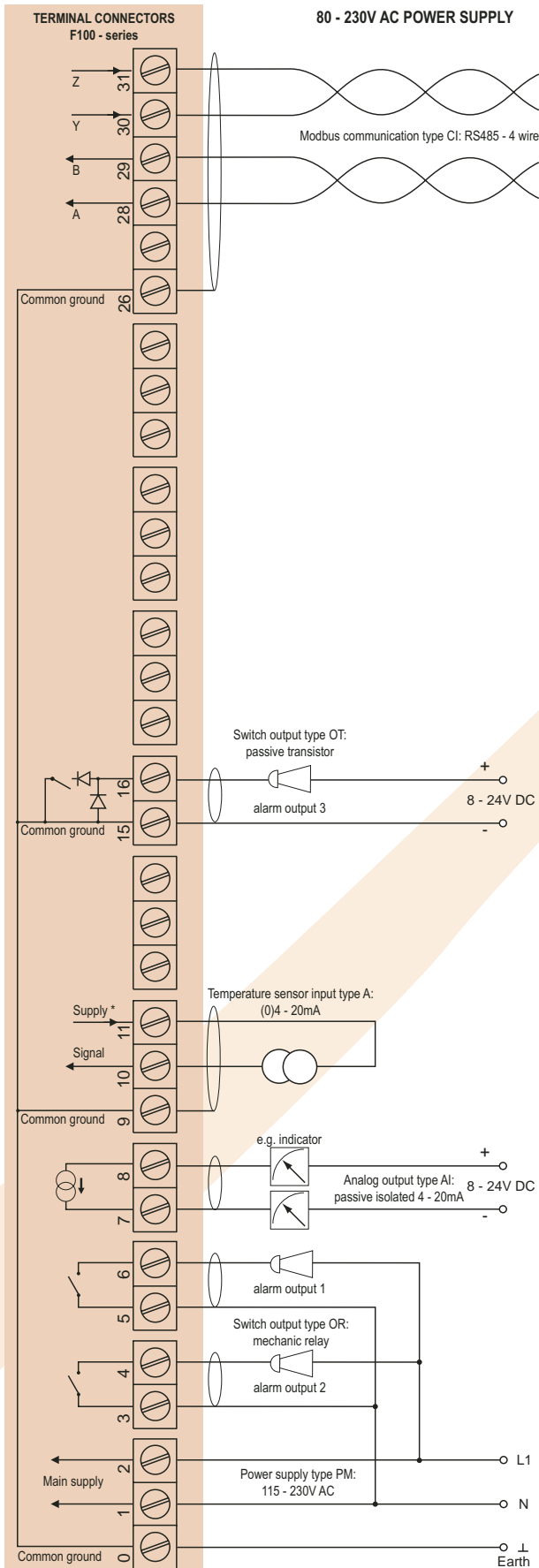

\*Supply voltage: 3.2 - 8.2 - 12 - 24V DC to sensor

Typical wiring diagram F143-T-AP-CB-OS-PD

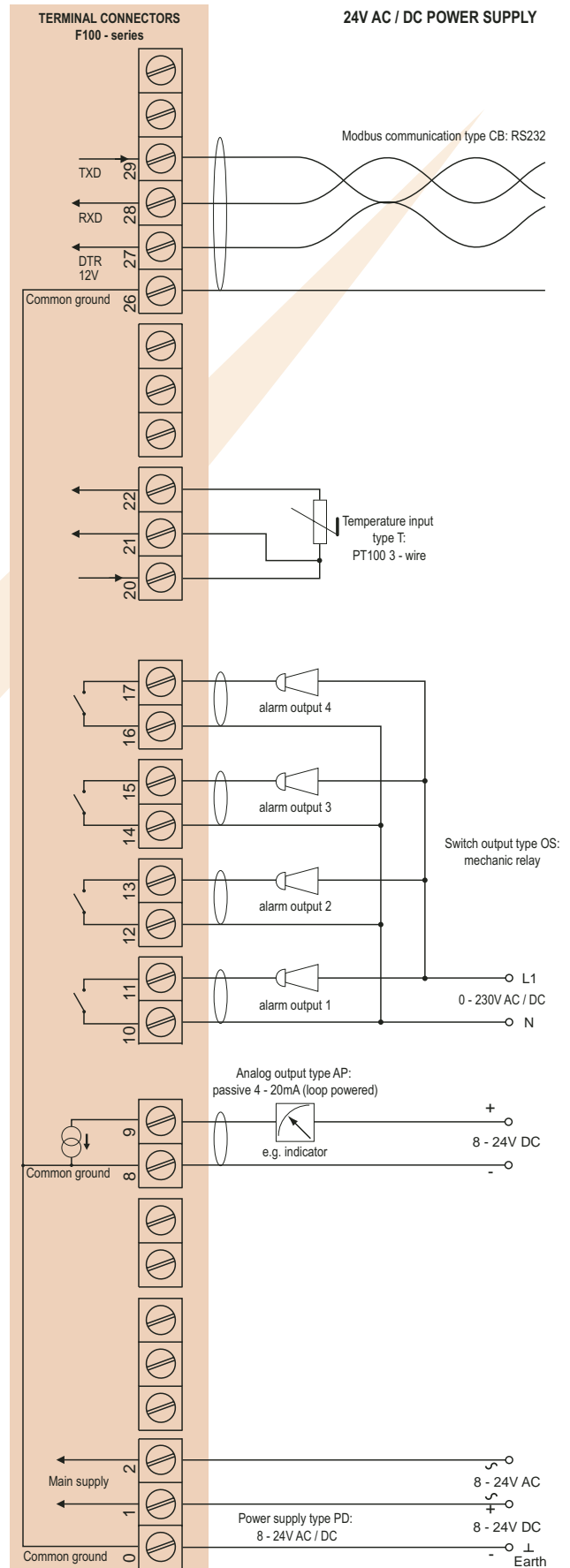

\*Supply voltage: 1.2 - 3.2 - 8.2 - 12 - 24V DC to sensor

## Hazardous area applications

The F143-XI has been ATEX approved by KEMA for use in intrinsically safe applications. It is approved according to  $\text{Ex}$  II 1GD EEx ia IIB/IIC T4 T100°C for gas and dust applications with an operational temperature range of -30°C to +70°C (-22°F to +158°F). Besides the I.S. power supplies for the two alarm outputs, it is allowed to connect up to three I.S. power supplies in IIB applications or one in IIC applications. Full functionality of the F143 remains available, including two alarm outputs and 4 - 20mA output and Modbus communication (type CT). Power supply type PD-XI offers a sensor supply according to the connected power supply voltage at terminal 1. A flame proof enclosure with rating  $\text{Ex}$  II 2G EEx d IIB T5 is available as well. Please contact your supplier for further details.

**Certificate of conformity KEMA 03ATEX1074 X**



## Configuration example IIB and IIC

### F143-T-(AP)-(CT)-(OT)-PC-XI - battery powered unit

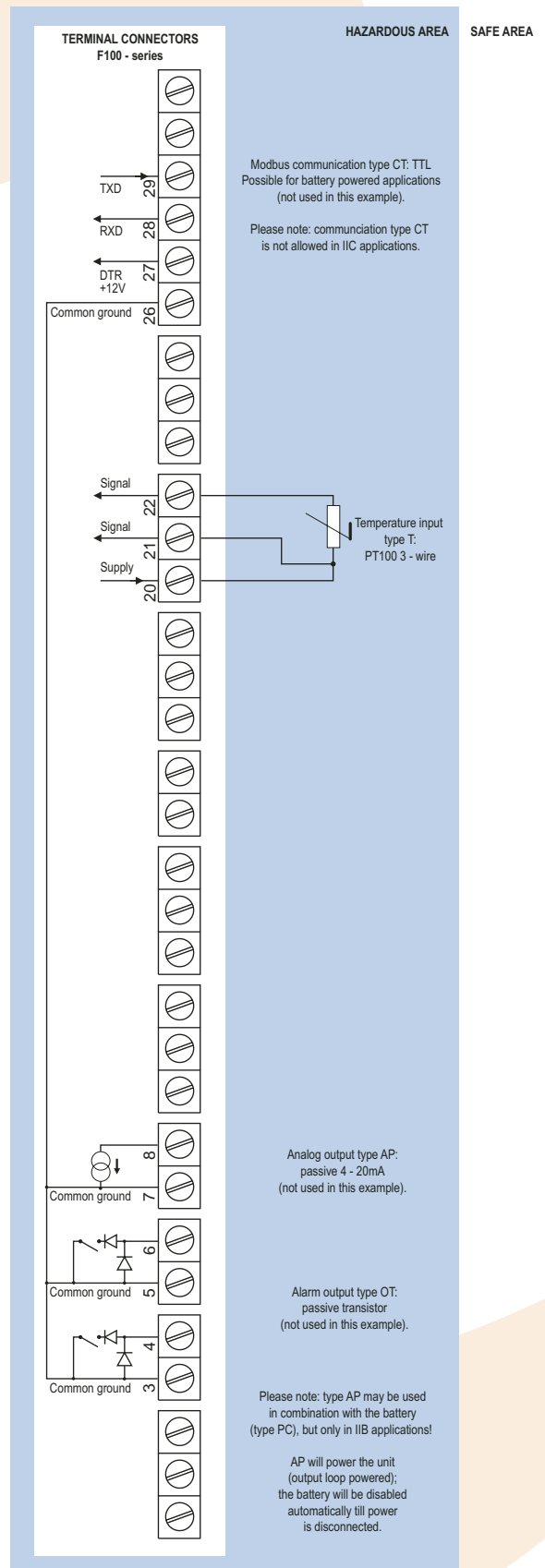

## Configuration example IIB - F143-A-AP-CT-OT-XI - output loop powered

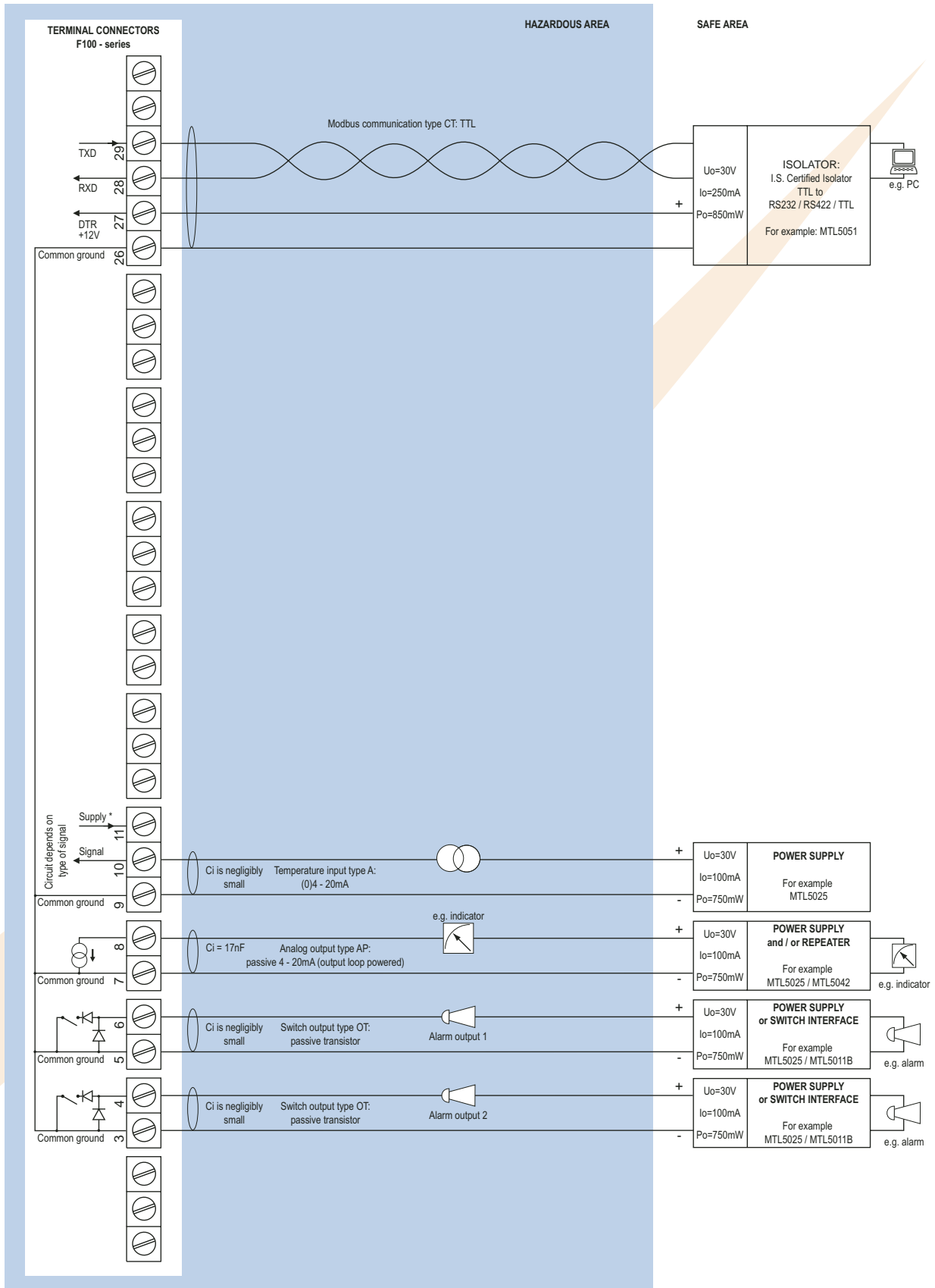

Configuration example IIB - F143-A-AF-CT-OT-PL-XI - input loop powered

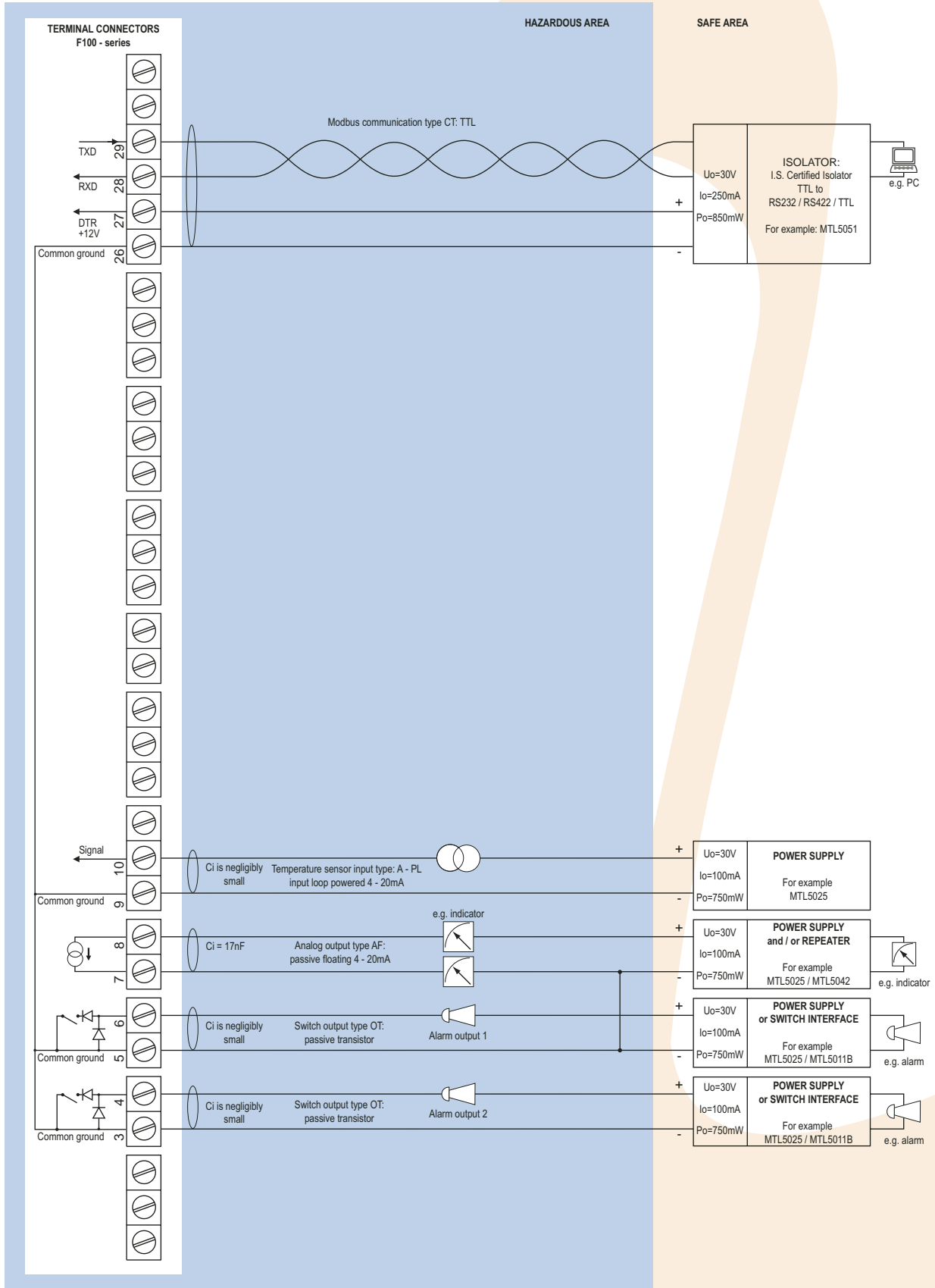

Configuration example IIB and IIC - F143-A-AP-(CT)-OT-PD-XI - power supply 16 - 30V DC

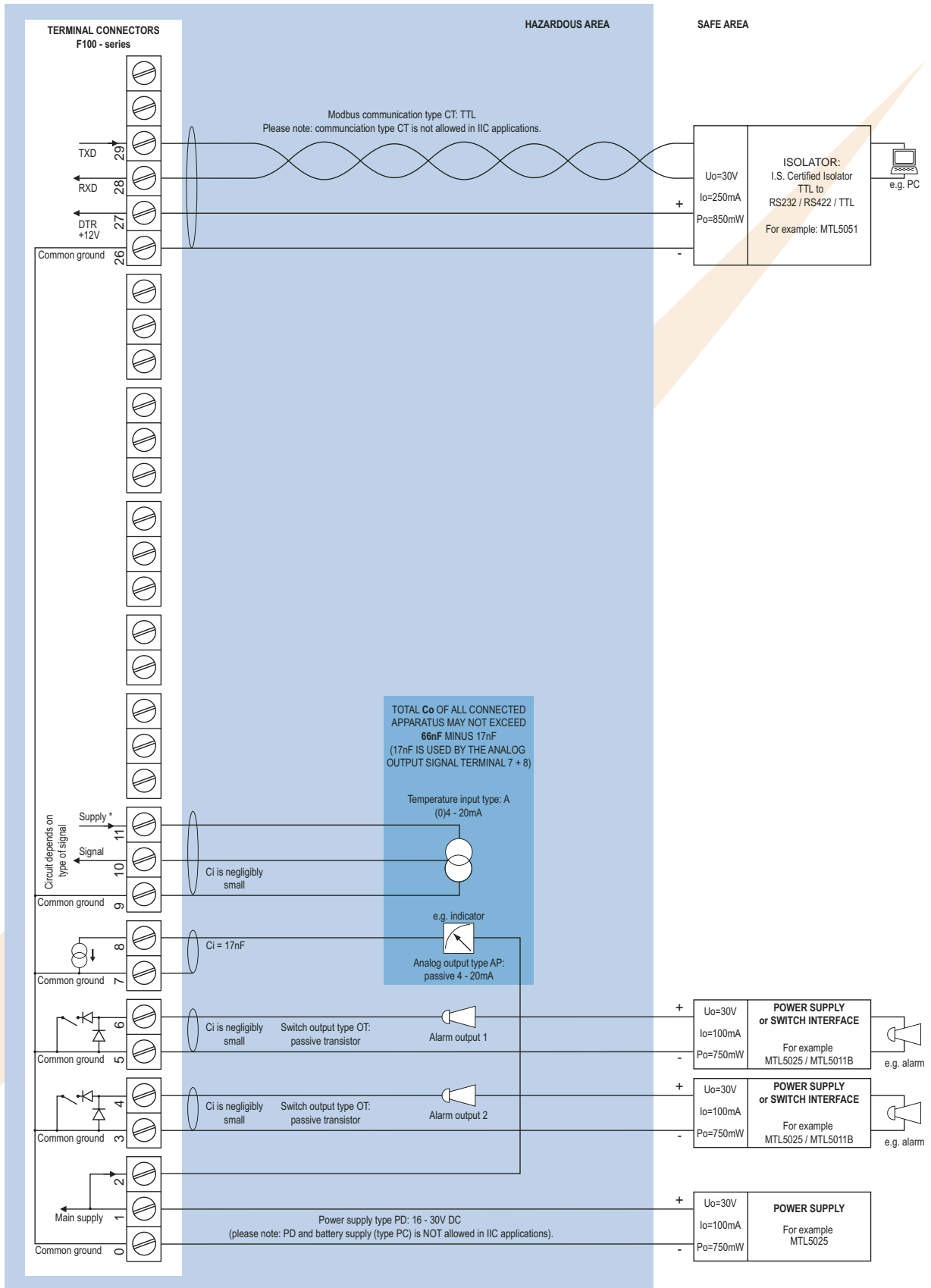

## Technical specification

### General

Display	
Type	High intensity reflective numeric and alphanumeric LCD, UV-resistant.
Dimensions	90 x 40mm (3.5" x 1.6").
Digits	Seven 17mm (0.67") and eleven 8mm (0.31") digits. Various symbols and measuring units.
Refresh rate	User definable: 8 times/sec. - 30 secs.
Option ZB	LED-backlight.

Casing	
Window	Polycarbonate window.
Sealing	EPDM and PE.
Control keys	Three industrial micro-switch keys. UV-resistant polyester keypad.
Type HA	Die-cast aluminum field mount enclosure IP67 / NEMA 4X with 2-component UV-resistant coating.
Dimensions	130 x 114 x 58mm (5.1" x 4.5" x 2.28") - W x H x D.
Cable Entry	2 x PG9 and 1 x M20 tapped hole in the centre.
Weight	950 gr.
Type HB	Die-cast aluminum panel mount enclosure IP65 / NEMA 4 with 2-component UV-resistant coating.
Dimensions	130 x 114 x 50mm (5.1" x 4.5" x 1.97") - W x H x D.
Panel cut-out	115 x 96mm (4.53" x 3.78") L x H.
Weight	525 gr.
Type HC	ABS panel mount enclosure IP65 / NEMA 4, UV-resistant and flame retardent.
Dimensions	130 x 114 x 48mm (5.1" x 4.5" x 1.89") - W x H x D.
Panel cut-out	115 x 96mm (4.53" x 3.78") L x H.
Weight	300 gr.
Type HD	ABS wall mount enclosure IP67 / NEMA 4X, UV-resistant and flame retardent.
Dimensions	130 x 114 x 71mm (5.1" x 4.5" x 2.8") - W x H x D.
Cable Entry	None, user defined.
Weight	400 gr.
Type HU	Die-cast aluminum field mount enclosure IP67 / NEMA 4X with 2-component UV-resistant coating.
Dimensions	5.1" x 4.5" x 2.28" - W x H x D.
Cable Entry	3 x 1/2" NPT tapped hole.
Weight	950 gr.



Operating temperature	
Operational	-30°C to +80°C (-22°F to +178°F).

Power requirements	
Type PB	Long life Lithium battery - life-time depends upon settings and configuration - up to 5 years.
Type PC	Intrinsically Safe long life lithium battery - life-time depends upon settings and configuration - up to 5 years.
Type PD	8 - 24V AC/DC ± 10%.
Type PD-XI	16 - 30V DC (Intrinsically Safe).
Type PF	24V AC/DC ± 10%.
Type PL	Input loop powered from sensor signal 4 - 20mA (type "A") - requires types AI or AF and OT.
Type PM	115 - 230V AC ± 10%.
Type PX	8 - 28V DC output loop powered unit with analog output signal type AP (or 8 - 24 V AC/DC if type AP will not be used).

Sensor excitation	
Type PB/PC/PX	3.2V DC.
Type PD	3.2 - 8.2 - 12 and 24V DC - max. 50mA@24V DC.
Type PD-XI	The sensor supply voltage will be according to power supply as connected to terminal 1.
Type PF / PM	3.2 - 8.2 - 12 and 24V DC - max. 200mA@24V DC.

Terminal connections	
Type	Removable plug-in terminal strip. Wire max. 1.5mm <sup>2</sup> and 2.5mm <sup>2</sup> .

Data protection	
Type	EEPROM backup of all settings. Data retention at least 10 years.
Pass-code	Configuration settings can be pass-code protected.

Hazardous area	
Intrinsically safe	ATEX approval ref:  II 1GD EEx ia IIB/IIC T4 T100°C.
Type XI	Maximum ambient +70°C (158°F).
Explosion proof	ATEX approval ref:  II 2G EEx d IIB T5.
Type XF	Dimensions of enclosure: 218 x 418 x 210mm (8.58" x 16.45" x 8.38") L x H x D.
Weight	16 Kg.

Environment	
Electromagnetic compatibility	Compliant ref: EN 61326 (1997), EN 61010-1 (1993).

### Signal inputs

Temperature	
Accuracy	14 bit. Error < 0.05%. Low level cut-off programmable.
Update time	Four times per second.
Type A	(0)4 - 20mA. Analog input signal can be scaled to any desired range within 0 - 20mA.
Span	0.000010 - 9,999,999 with variable decimal position.
Offset	0.00 - 99,999.99 K.
Voltage drop	2.5V@20mA.
Type T	2 or 3 wire PT100.
Range	-100°C to +200°C (-148°F to 392°F). Accuracy 0.1°C (0.18°F).
Option ZV	Range: -200°C to +800°C (-328°F to 1832°F). Accuracy 0.5°C (0.9°F).
Type U	0 - 10V DC. Analog input signal can be scaled to any desired range within 0 - 10V DC.
Span	0.000010 - 9,999,999 with variable decimal position.
Offset	0.00 - 99,999.99 K.
Load impedance	3kΩ.
Note	For signal A and U: power supply to temperature sensor is required; e.g. PD.

## Signal outputs

### Analog output

Function	Transmitting actual temperature.
Accuracy	10 bit. Error < 0.05%. Analog output signal can be scaled to any desired range.
Update time	Ten times per second.
Type AA	Active 4 - 20mA output (requires OA + PD, PF or PM).
Type AB	Active 0 - 20mA output (requires OA + PD, PF or PM).
Type AF	Passive floating 4 - 20mA output for Intrinsically Safe applications (requires PC, PD or PL).
Type AI	Passive galvanically isolated 4 - 20mA output - also available for battery powered models (requires PB, PD, PF, PL or PM).
Type AP	passive 4 - 20mA output - not isolated. Unit will be loop powered.
Type AU	Active 0 - 10V DC output (requires OA + PD, PF or PM).

### Alarm output

Function	User defined: low, low-low, high, high-high or all alarms output.
Type OA	Three active 24V DC transistor outputs (PNP); max. 50mA per output (requires AA + PD, PF or PM).
Type OR	Two electro-mechanical relay outputs isolated (N.O.) - max. switch power 230V AC - 0.5A (requires PF or PM) and one transistor output OT or OA (OA in combination with AA only).
Type OS	Four electro-mechanical relay outputs - isolated; max. switch power 230V AC - 0.5A per relay (requires AP and PD).
Type OT	Three passive transistor outputs (NPN) - not isolated.
Load	Max. 50V DC - 300mA per output.
Note	Intrinsically Safe applications: only two transistor outputs type OT available.

### Communication option

Function	Reading display information, reading / writing all configuration settings.
Type CB	RS232
Type CH	RS485 2-wire
Type CI	RS485 4-wire
Type CT	TTL Intrinsically Safe.
Protocol	Modbus ASCII / RTU.
Speed	1200 - 2400 - 4800 - 9600 baud.
Addressing	Maximum 255 addresses.

## Operational

### Operator functions

Displayed functions	<ul style="list-style-type: none"> <li>• Actual temperature.</li> <li>• Low - low alarm value.</li> <li>• Low alarm value.</li> <li>• High alarm value.</li> <li>• High - high alarm value.</li> <li>• Alarm values can be set (or only displayed).</li> </ul>
---------------------	--

### Line temperature

Digits	6 digits.
Units	°C, °F or K.
Decimals	1.

### Alarm values

Digits	7 digits.
Units	According to the settings for temperature.
Decimals	According to the settings for temperature.
Time units	According to the settings for temperature.
Type of alarm	Low, high, low-low or high-high temperature alarm. Includes alarm delay time and configurable alarm outputs.

## Display example - 90 x 40mm (3.5" x 1.6")



## Ordering information

Example (standard configuration)

F143-A-AP-CX-HC-OT-PX-XX-ZX.

Explanation standard configuration:

**A:** temperature signal: (0)4 - 20mA analog input; **AP:** passive 4 - 20mA analog output;

**CX:** no communication; **HC:** ABS panel mount enclosure; **OT:** passive transistor output; **PX:** the unit is powered by the analog output loop, type AP: 8 - 28V DC (or AC); **XX:** Safe area; **ZX:** no options.

Ordering information:	F143	-	-A	-C	-H	-O	-P	-X	-Z
<b>Temperature signal</b>									
<b>A</b> ⓘ	<b>(0)4 - 20mA input.</b>								
T ⓘ	PT100 input.								
U ⓘ	0 - 10V DC input.								
<b>Analog output signal</b>									
AA	Active 4 - 20mA output - requires OA + PD, PF or PM.								
AB	Active 0 - 20mA output - requires OA + PD, PF or PM.								
AF ⓘ	I.S. floating 4 - 20mA output - requires PC, PD or PL.								
AI	Isolated 4 - 20mA output - requires PB, PD, PF, PL or PM.								
<b>AP</b> ⓘ	<b>Passive 4 - 20mA output, loop powered unit.</b>								
AU	Active 0 - 10V DC output - requires OA + PD, PF or PM.								
<b>Communication</b>									
CB	Communication RS232 - Modbus ASCII / RTU.								
CH	Communication RS485 - 2-wire - Modbus ASCII / RTU.								
CI	Communication RS485 - 4-wire - Modbus ASCII / RTU.								
CT ⓘ	Intrinsically Safe TTL - Modbus ASCII / RTU.								
<b>CX</b> ⓘ	<b>No communication.</b>								
<b>Enclosure</b>									
HA ⓘ	Aluminum field mount enclosure IP67 / NEMA 4X.								
HB ⓘ	Aluminum panel mount enclosure IP65 / NEMA 4.								
<b>HC</b> ⓘ	<b>ABS panel mount enclosure IP65 / NEMA 4.</b>								
HD ⓘ	ABS wall mount enclosure IP67 / NEMA 4X.								
HU ⓘ	Aluminum field mount enclosure IP67 / NEMA 4X.								
<b>Outputs</b>									
OA	Three active transistor outputs - requires AA, AB or AU and PD, PF or PM.								
OR	Two mechanic relay outputs + one OT or OA - requires PF or PM.								
OS	Four mechanic relay outputs - requires AP and PD.								
<b>OT</b> ⓘ	<b>Three passive transistor outputs - standard configuration.</b>								
<b>Power supply</b>									
PB	Lithium battery powered.								
PC ⓘ	Lithium battery powered - Intrinsically Safe.								
PD ⓘ	8 - 24V AC / DC + sensor supply - with XI: 16 - 30V DC.								
PF	24V AC / DC + sensor supply.								
PL ⓘ	Input loop powered from sensor signal type "A" - requires AI or AF and OT.								
PM	115 - 230V AC + sensor supply.								
<b>PX</b> ⓘ	<b>No power supply option. Unit requires external loop AP.</b>								
<b>Hazardous area</b>									
XI ⓘ	Intrinsically safe.								
XF ⓘ	EExd enclosure - 3 keys.								
<b>XX</b>	<b>Safe area only.</b>								
<b>Other options</b>									
ZB	Backlight.								
ZV ⓘ	PRTD-range -200°C / +800°C.								
<b>ZX</b> ⓘ	<b>No options.</b>								

The bold marked text contains the standard configuration.

ⓘ Available Intrinsically Safe.

Specifications are subject to change without notice.

FLUIDWELL bv  
P.O. Box 6  
5460 AA - Veghel - The Netherlands  
Tel.: +31 (0)413 343786  
Fax.: +31 (0)413 363443  
sales@fluidwell.com  
Internet: www.fluidwell.com

