

FLOWRATE INDICATOR / TOTALIZER

WITH LINEARISATION AND PULSE
SIGNAL OUTPUT



Features

- Displays instantaneous flowrate, total and accumulated total.
- 15 point linearisation of the flowcurve - with interpolation.
- Large 17mm (0.67") digit selection for flowrate or total.
- Ability to process all types of flowmeter signals.
- Auto backup of settings and running totals.
- Operational temperature -40°C up to +80°C (-22°F up to 178°F).
- Very compact design for panel mount, wall mount or field mount applications.
- Rugged aluminum field mount enclosure IP67/NEMA4X.
- Intrinsically safe
⊕ II 1GD EEx ia IIB/IIC T4 T100°C.
- Explosion/flame proof ⊕ II 2G EEx d IIB T5.
- LED backlight option.
- Loop or battery powered, 8 - 24V AC/DC or 115 - 230V AC power supply.
- Sensor supply 3.2 - 8.2 - 12 - 24V DC.

Signal output

- Scaled pulse output according to linearised accumulated total.

Signal input

Flow

- Reed-switch.
- NAMUR.
- NPN/PNP pulse.
- Coil (sine wave).
- Active pulse signals.
- (0)4 - 20mA.
- 0 - 10V DC.

Applications

- Liquid flow measurement with mechanic flowmeters where a precise calculation over the full measurement range is required. Also re-transmission of the totaliser function is desired. Alternative more advanced models: F112 - F118.

General information

Introduction

The F016 is a local indicator with linearisation to display the actual flowrate, total and accumulated total. In addition to the average K-Factor or Span, fifteen linearisation points can be entered. The unit will interpolate between these points greatly enhancing accuracy in any flowrange. This linearisation effects all displayed information as well as the pulse output. A wide selection of options further enhance this models capabilities.

Display

The display has large 17mm (0.67") and 8mm (0.31") digits which can be set to show flowrate and totals. On-screen engineering units are easily configured from a comprehensive selection. The accumulated total can register up to 11 digits and is backed-up in EEPROM memory every minute, just as the running total. A smart display update function achieves a readable display even at -40°C / -40°F.

Backlight

For those applications where readability during day is an issue, a bi-color backlight is available. The background color green or amber and the intensity can be adjusted from the keyboard. The display is a transfective type, which means that a high contrast reading is guaranteed in full sunlight as well as during the night. This back-light option is also available Intrinsically Safe.

Configuration

All configuration settings are accessed via a simple operator menu which can be pass-code protected. Each setting is clearly indicated with an alphanumerical description, therefore avoiding confusing abbreviations. Once familiar with one F-series product, you will be able to program all models in the series without a manual.

Pulse output

The scaleable pulse output reflects the count on the accumulated display. The pulse length is user defined from 0.001 second up to 10 seconds. The maximum output frequency is 500Hz. The output signal can be a passive NPN or an active PNP transistor, or an isolated electro-mechanical relay.

Signal input

The F016 will accept most pulse and analog input signals for flow or mass flow measurement. The input signal type can be selected by the user in the configuration menu without having to adjust any sensitive mechanical dip-switches, jumpers or trimmers. The analog input version is even available as 4 - 20mA input loop powered display.

Power supply

Several power supply options are available to power the F016 and sensor. Most popular is our battery powered version with a long life lithium battery which will last up to five years.

For analog sensors, a 4 - 20mA loop powered version is available as well. A real sensor supply is offered with the 24V AC/DC or 115 - 230V AC power supply option.

Hazardous areas

For hazardous area applications, ATEX Intrinsically Safe certification is pending according to $\text{Ex II 1GD EEx ia IIB / IIC T4 T100}^\circ\text{C}$ with an allowed operational temperature of -40°C to +70°C (-40°F to +158°F). CSA and IEC certification is expected to be available in november 2005.

A flame proof enclosure with ATEX certification offers the rating $\text{Ex II 2G EEx d IIB T5}$.

Enclosures

Various types of enclosures can be selected. As standard the F016 is supplied in an ABS panel mount enclosure. Most popular is our aluminum field mount enclosure with IP67 / NEMA 4X rating. Both European or U.S. cable gland entry threads are available.

Overview application F016

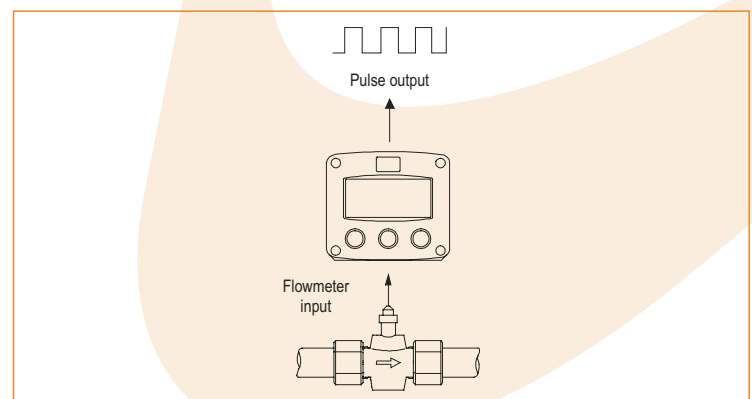

Dimensions enclosures

Enclosure HA

Aluminum field mount enclosure

IP67 / NEMA 4X
Tapped holes: European thread

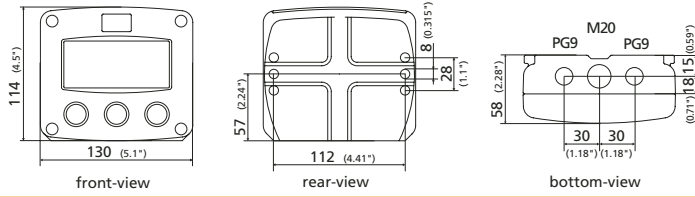

Enclosure HB

Aluminum panel mount enclosure

IP65 / NEMA 4

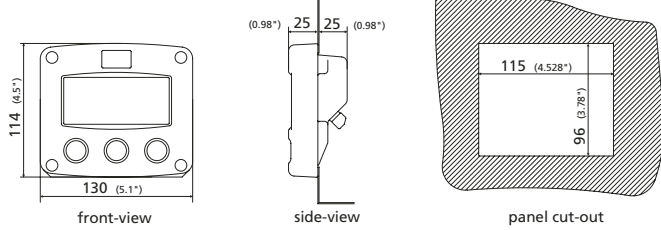

ENCLOSURE HC (STANDARD)

ABS PANEL MOUNT ENCLOSURE

IP65 / NEMA 4

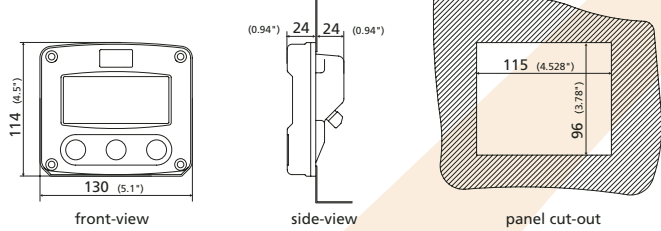

Enclosure HD

ABS wall mount enclosure

IP67 / NEMA 4X
Holes user defined

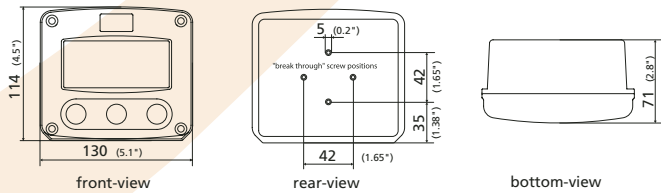

Enclosure HU

Aluminum field mount enclosure

IP67 / NEMA 4X
Tapped holes: U.S. thread

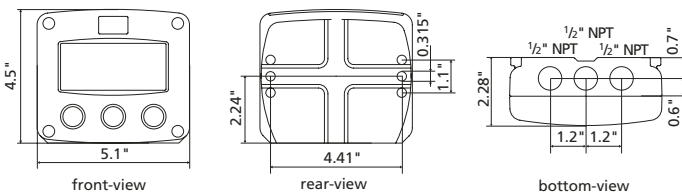

Terminal connections power supply

PB/PC - PD - PL - PX

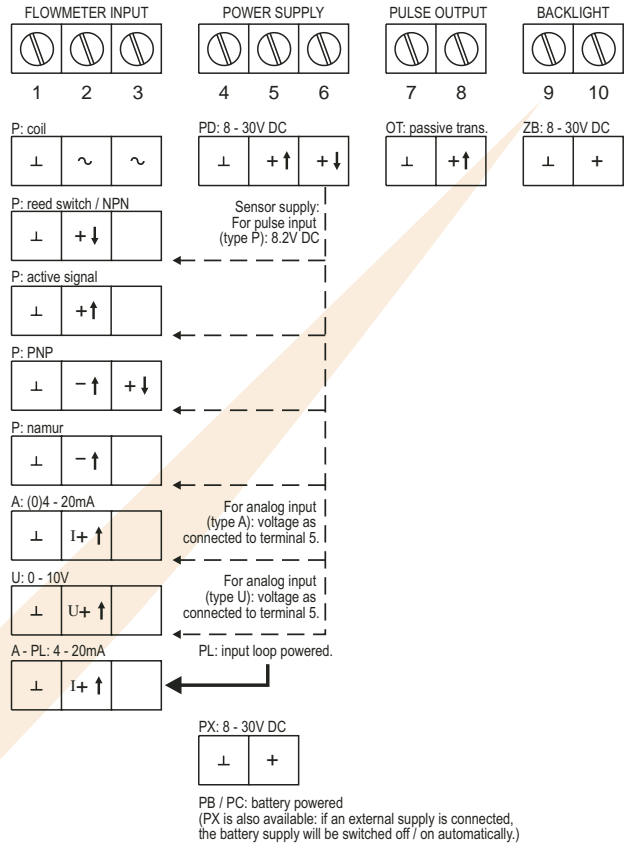

Terminal connections power supply PF - PM

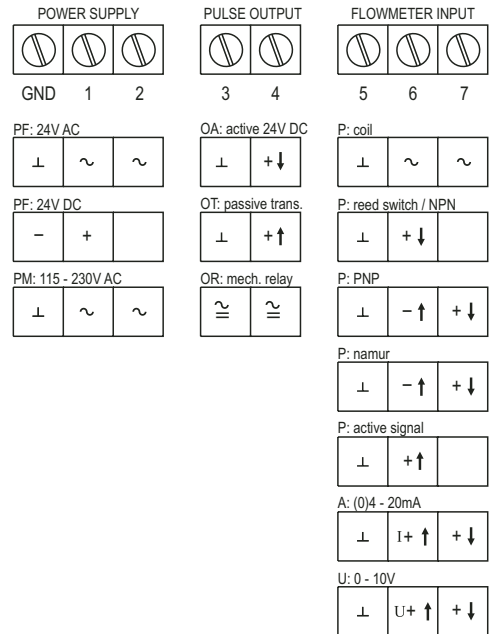

Typical wiring diagram Fo16-P-(OT)-PB-(PX)-(ZB)

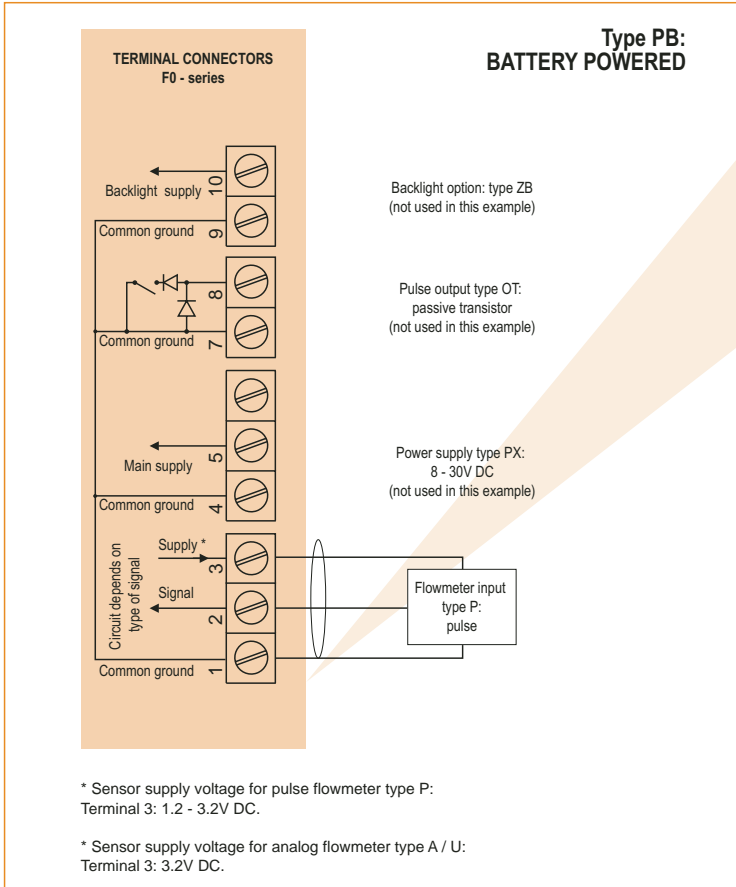

Typical wiring diagram Fo16-A-OT-PX-ZB

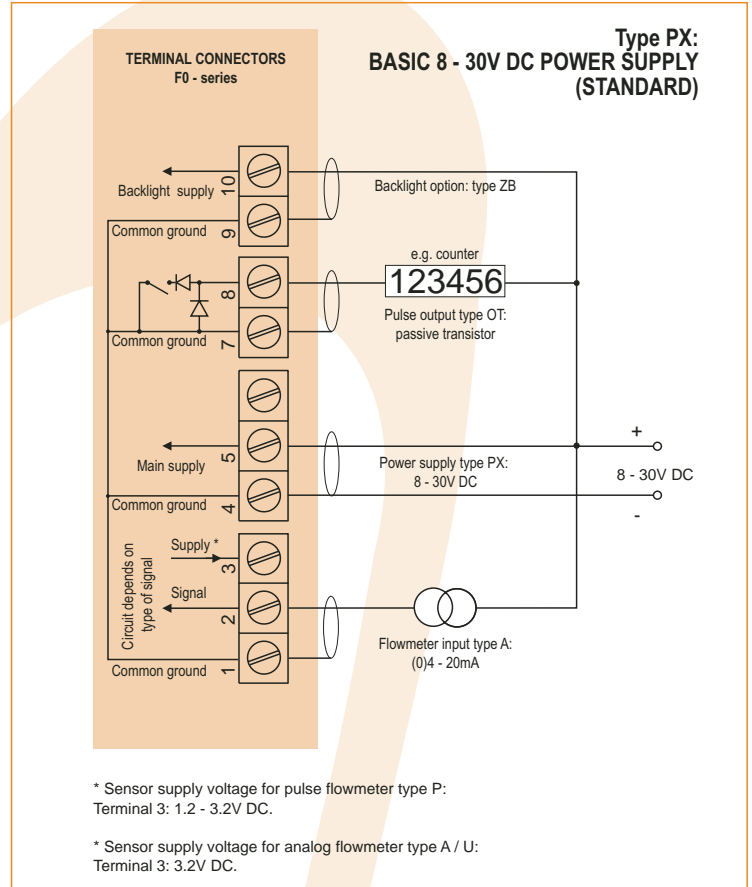

Typical wiring diagram Fo16-A-(OT)-PL-ZB

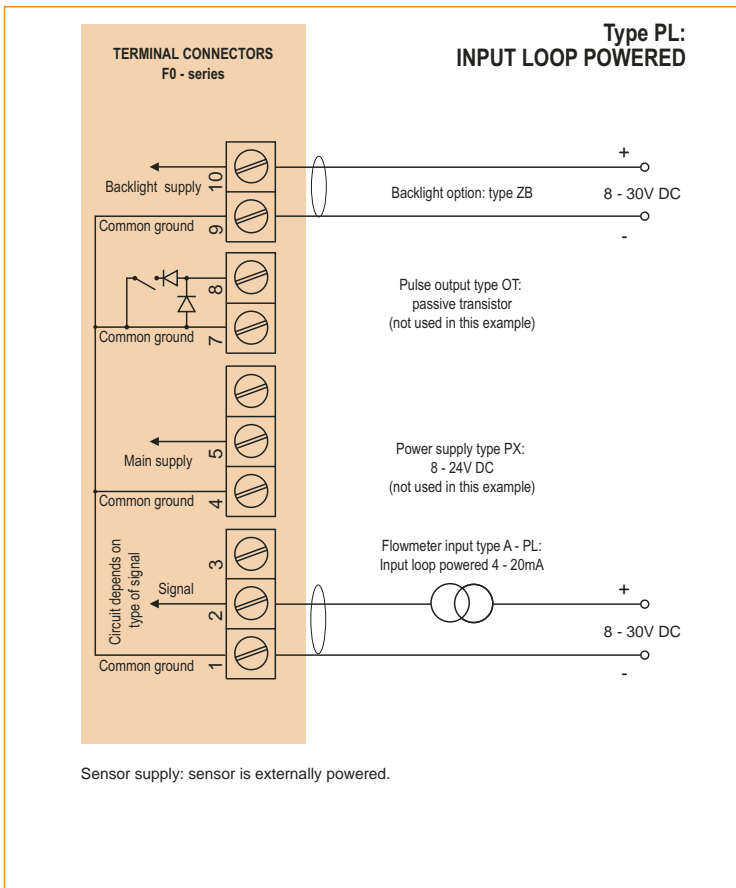

Typical wiring diagram Fo16-P-OT-PD-ZB

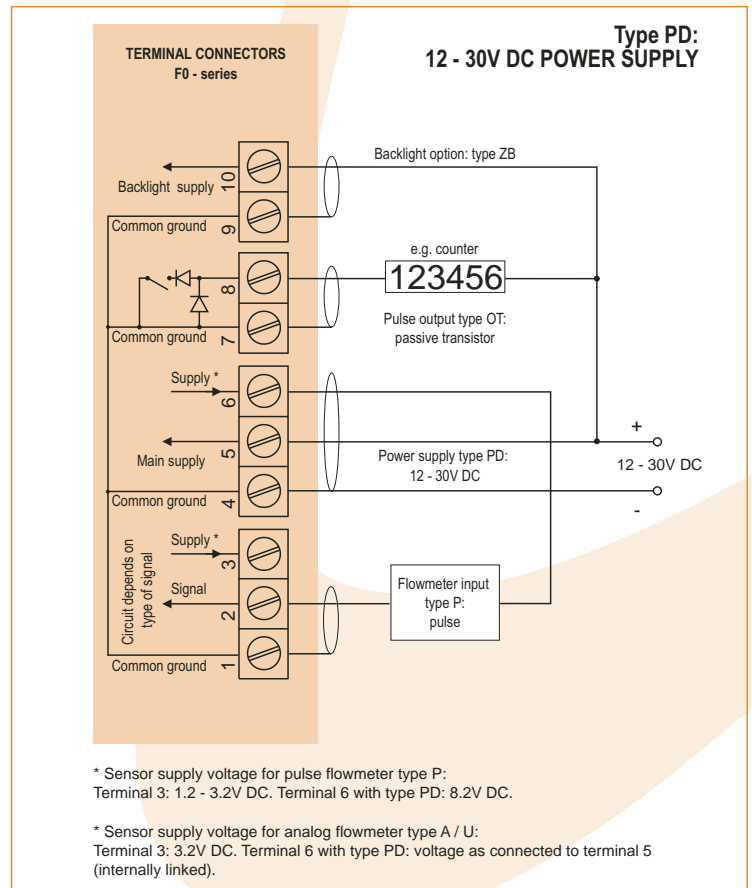

Typical wiring diagram Fo16-P-OA-PF-ZB

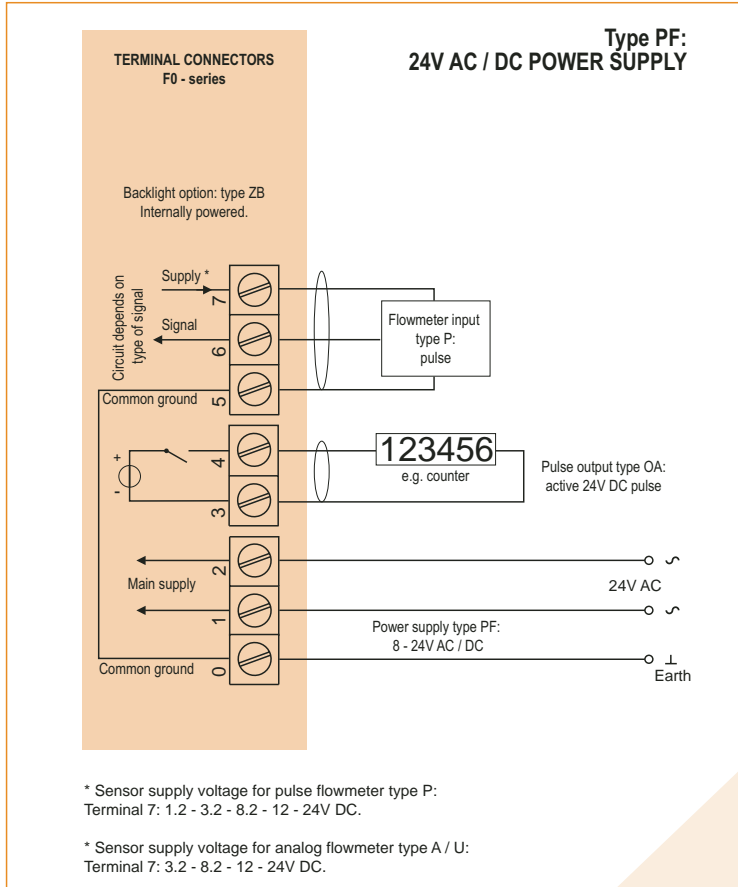

Typical wiring diagram Fo16-A-OT-PF-ZB

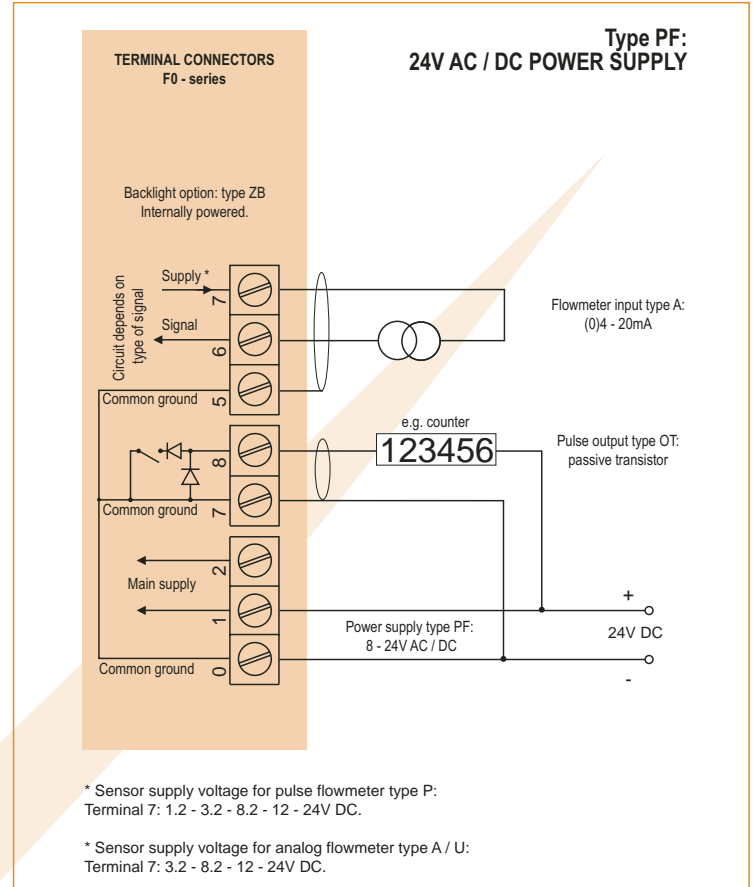

Typical wiring diagram Fo16-A-OA-PM-ZB

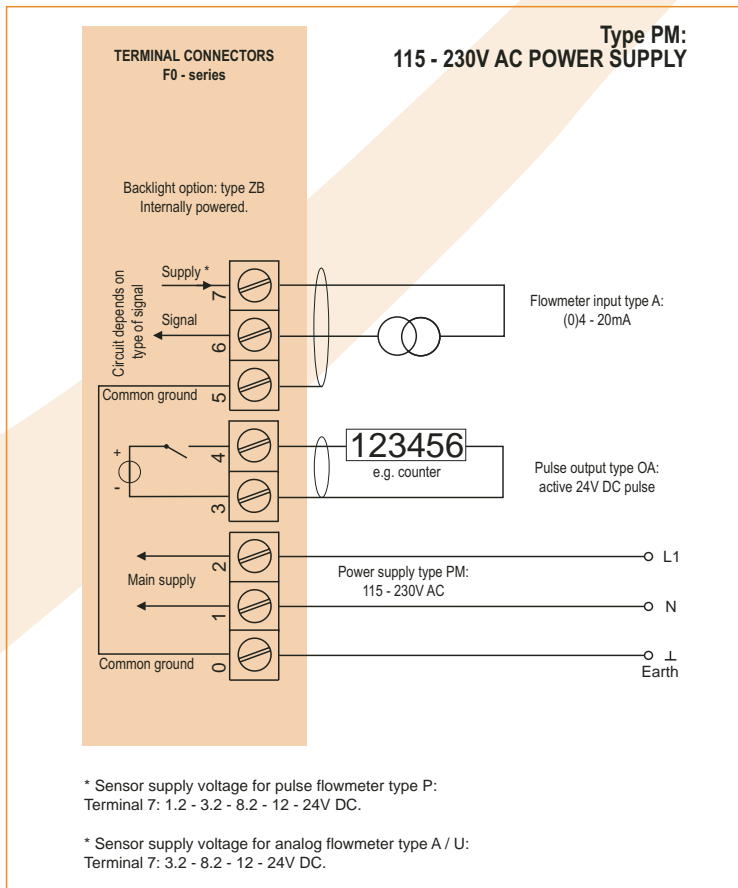

Typical wiring diagram Fo16-P-OR-PM-ZB

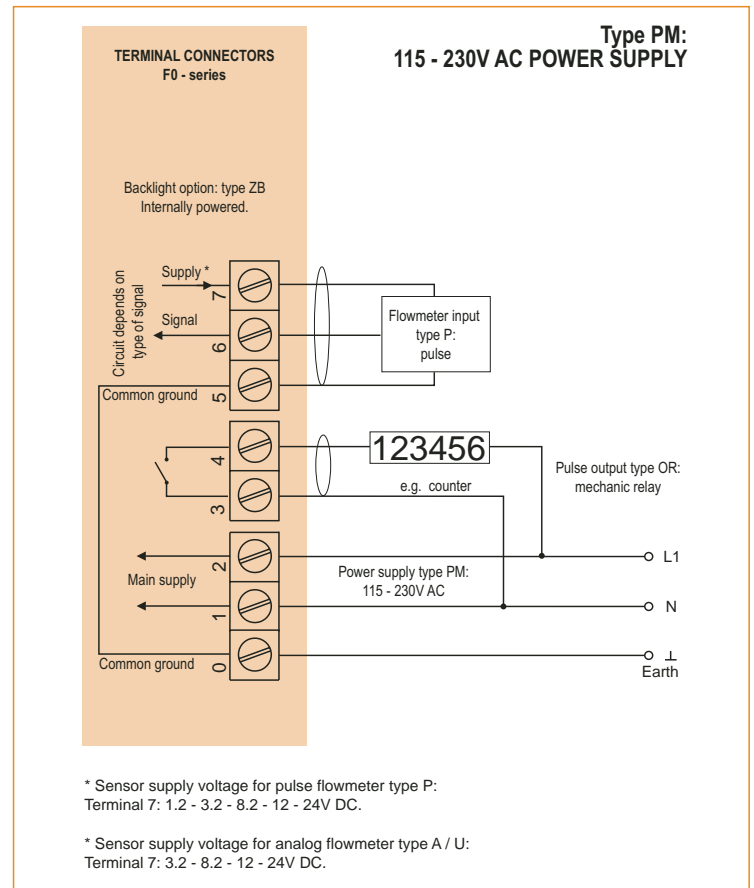

Hazardous area applications

ATEX certification of the F016-XI for use in Intrinsically Safe applications is pending. It is going to be approved according to Ex II 1GD EEx ia IIB/IIC T4 T100°C for gas and dust applications with an operational temperature range of -40°C to +70°C (-40°F to +158°F).

IEC certification with the same ratings is expected to become available in november 2005, just as the CSA certification. The CSA (US/C) rating will be: Intrinsically Safe Class I, II, or III, Zone 0 or 1, Division 1 or 2, Group A through G (I.S.) and Non-Incendive Division 2 and Zone 2 (N.I.).

A flame proof enclosure with rating Ex II 2G EEx d IIB T5 is available as well. Please contact your supplier for further details.

Certificate of conformity KEMA 03ATEX1074 X



Configuration example IIB and IIC

F016-P-(OT)-PC-(PX)-XI-(ZB) - battery powered unit

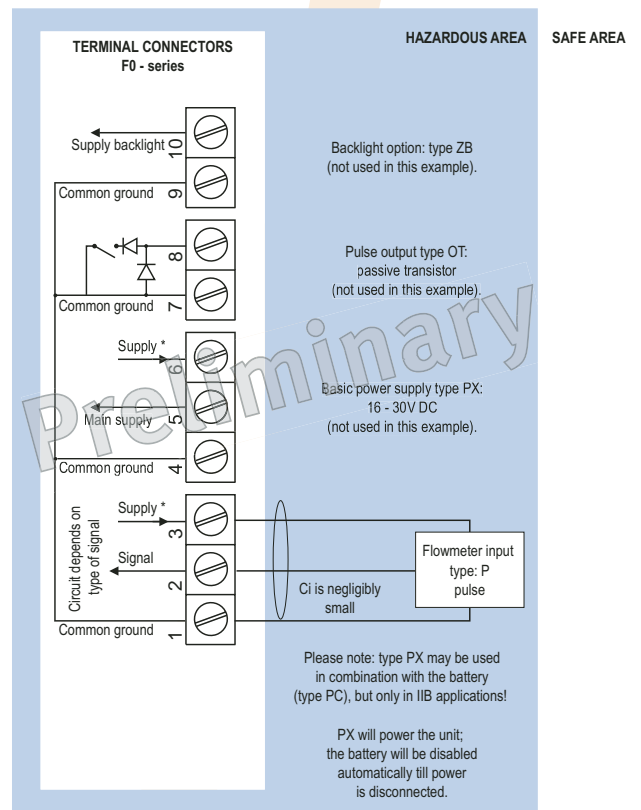

* Sensor supply voltage for pulse flowmeter type P: Terminal 3: 1.2 - 3.2V DC.
* Sensor supply voltage for analog flowmeter type A / U: Terminal 3: 3.2V DC.

Configuration example IIB and IIC - F016-P-OT-PX-XI-(ZB) - basic power supply 8 - 30V DC

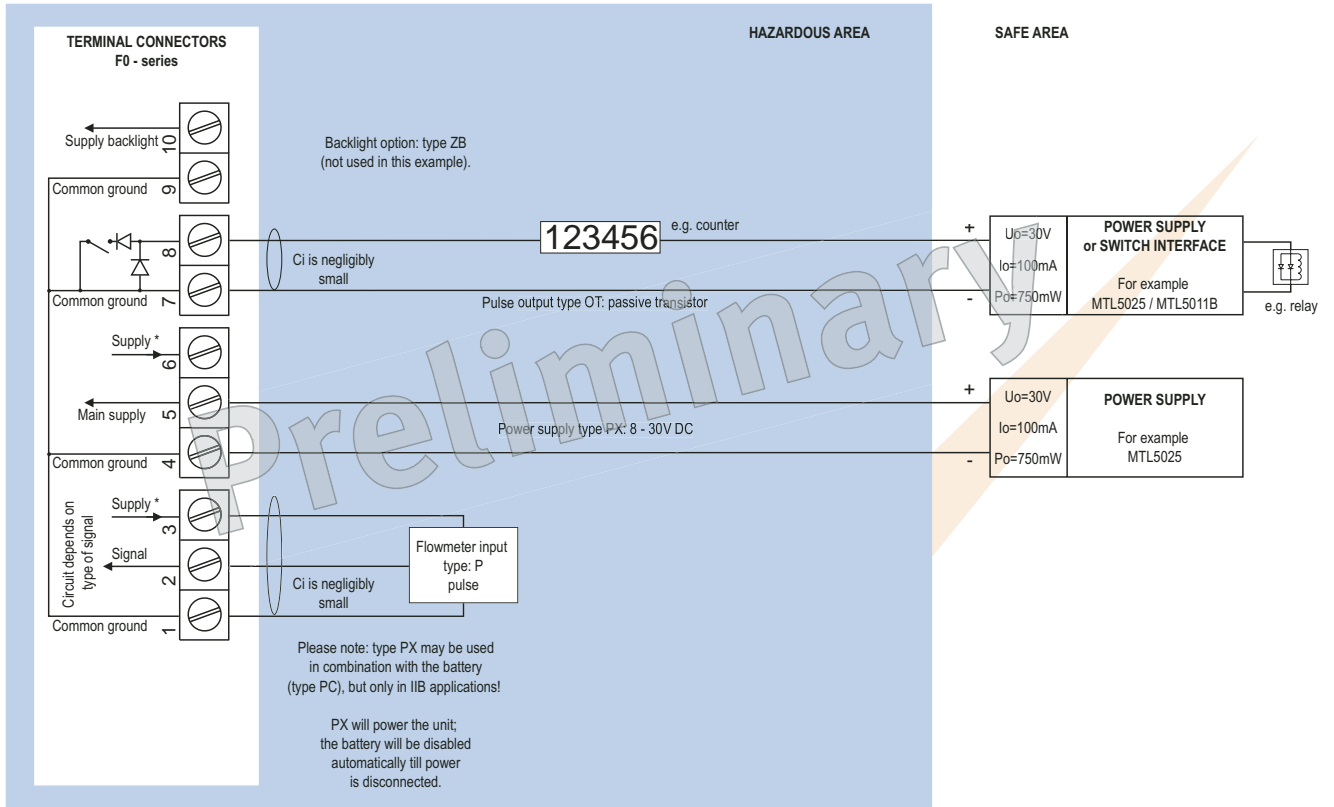

* Sensor supply voltage for pulse flowmeter type P: Terminal 3: 1.2 - 3.2V DC.
* Sensor supply voltage for analog flowmeter type A / U: Terminal 3: 3.2V DC.

Configuration example IIB and IIC - F016-P-OT-PX-XI-ZB - basic power supply 8 - 30V DC

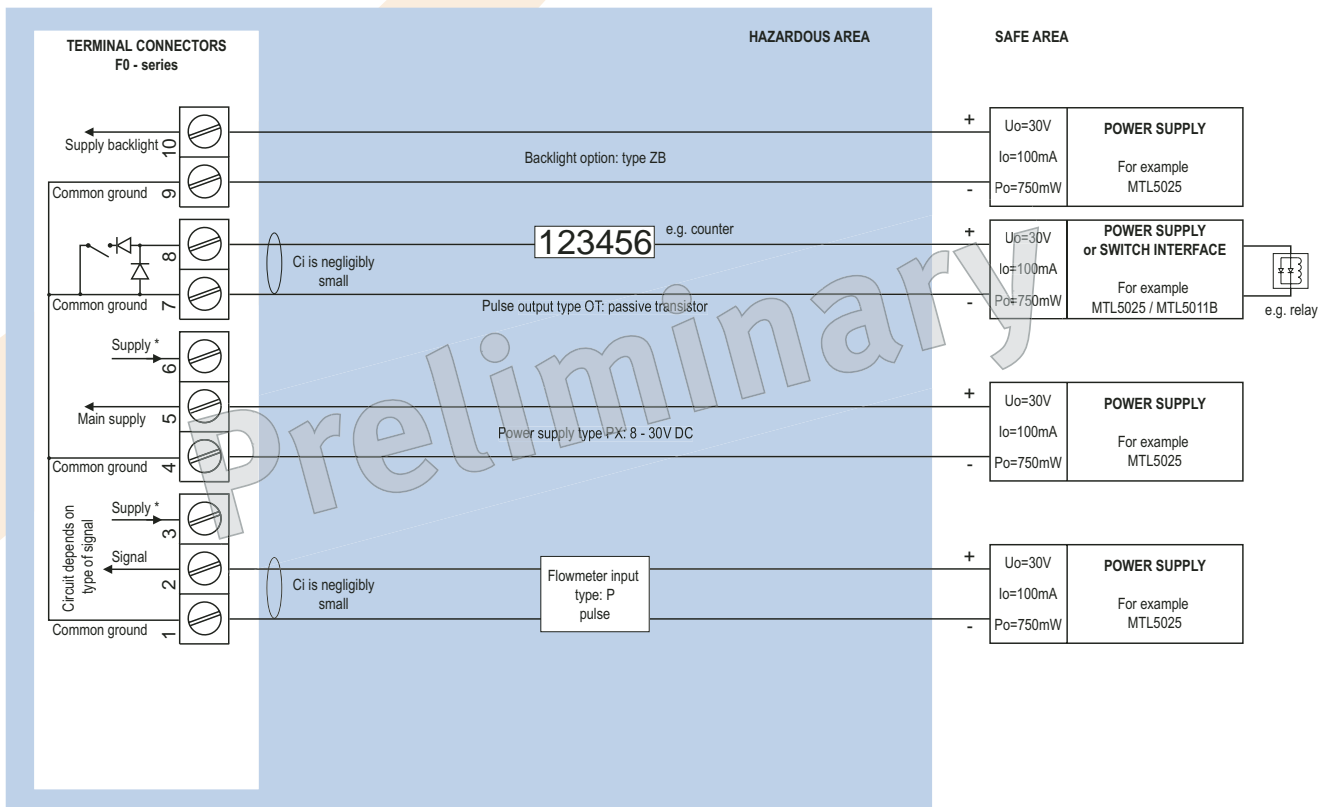

* Sensor supply voltage for pulse flowmeter type P: Terminal 3: 1.2 - 3.2V DC.
* Sensor supply voltage for analog flowmeter type A / U: Terminal 3: 3.2V DC.

Configuration example IIB and IIC - Fo16-P-OT-PD-XI-ZB - power supply 16 - 30V DC

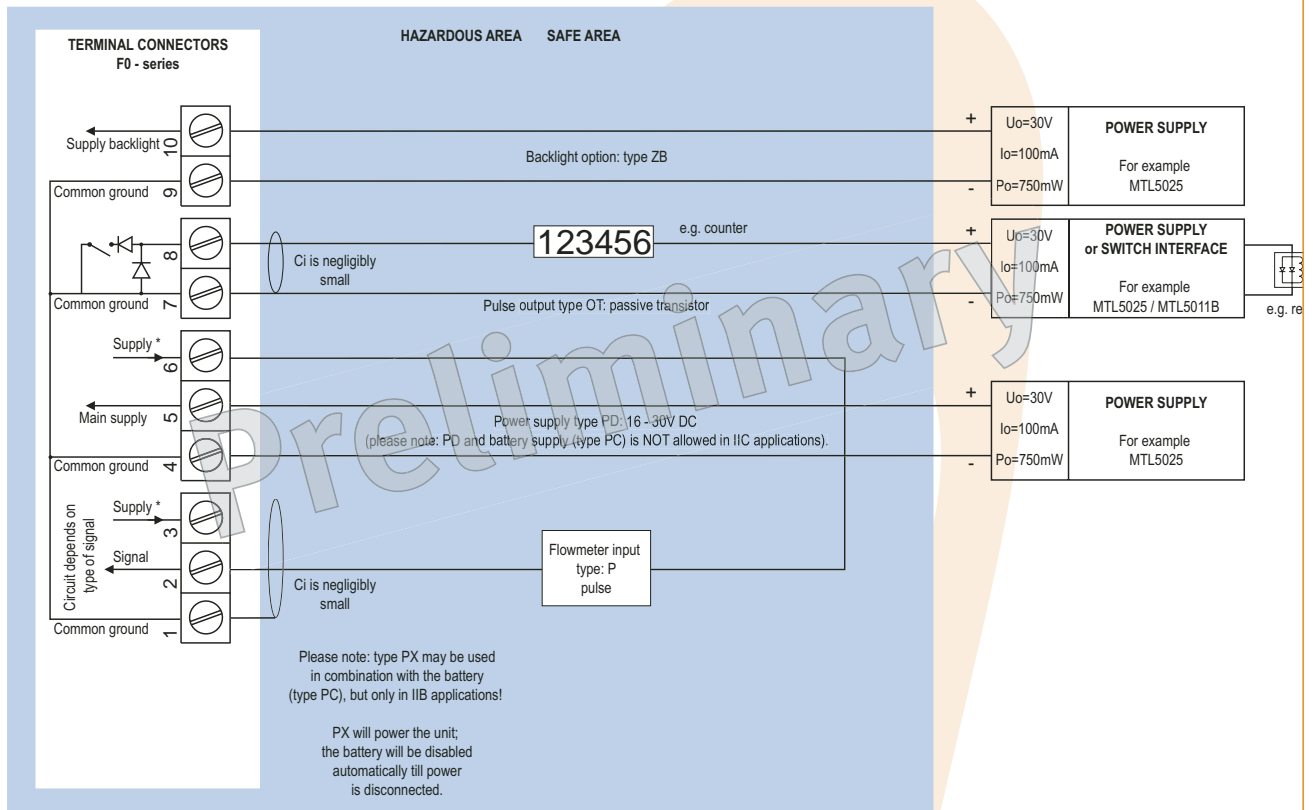

* Sensor supply voltage for pulse flowmeter type P: Terminal 3: 1.2 - 3.2V DC. Terminal 6 with type PD: 8.2V DC.
 * Sensor supply voltage for analog flowmeter type A / U: Terminal 3: 3.2V DC. Terminal 6 with type PD: voltage as connected to terminal 5 (internally linked).

Configuration example IIB and IIC - Fo16-A-OT-PD-XI-ZB - power supply 16 - 30V DC

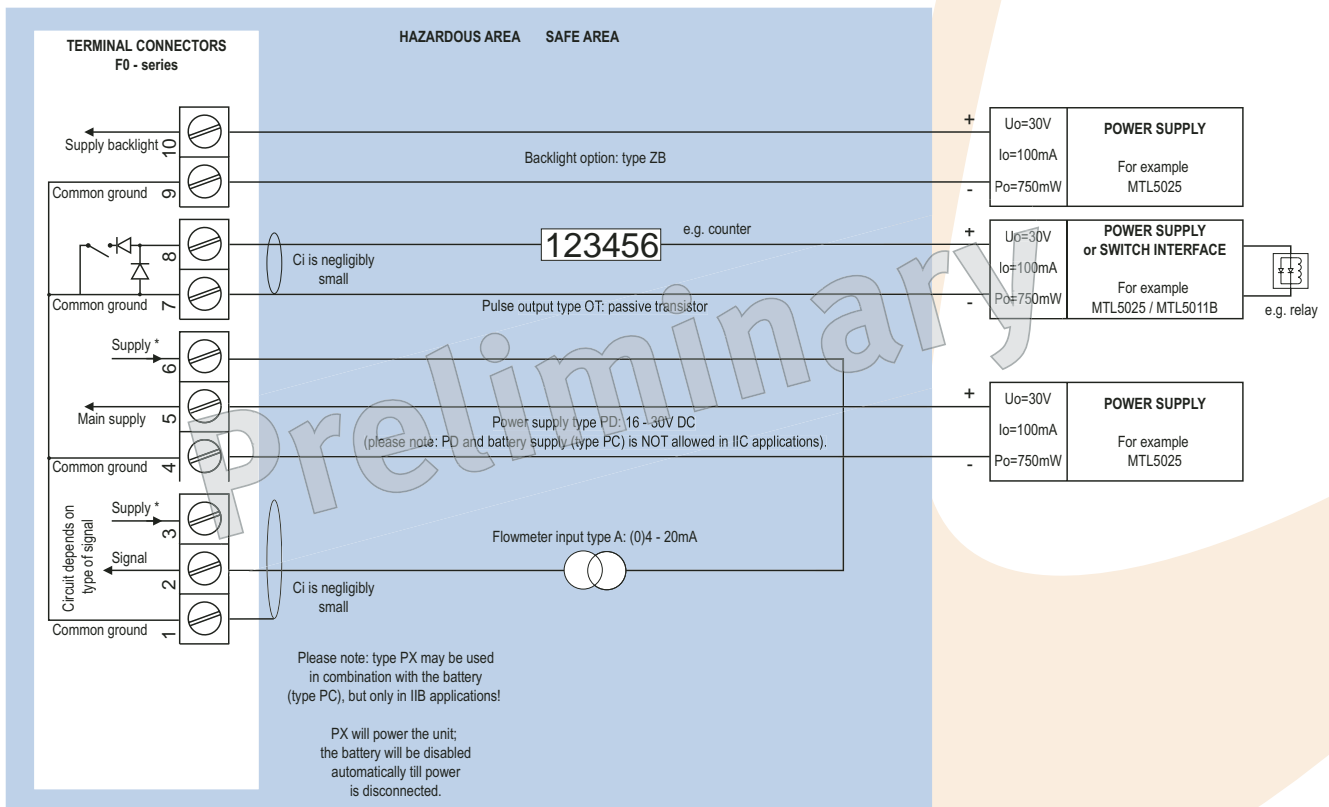

* Sensor supply voltage for pulse flowmeter type P: Terminal 3: 1.2 - 3.2V DC. Terminal 6 with type PD: 8.2V DC.
 * Sensor supply voltage for analog flowmeter type A / U: Terminal 3: 3.2V DC. Terminal 6 with type PD: voltage as connected to terminal 5 (internally linked).

Configuration example IIB and IIC - F016-A-OT-PL-XI-ZB - input loop powered

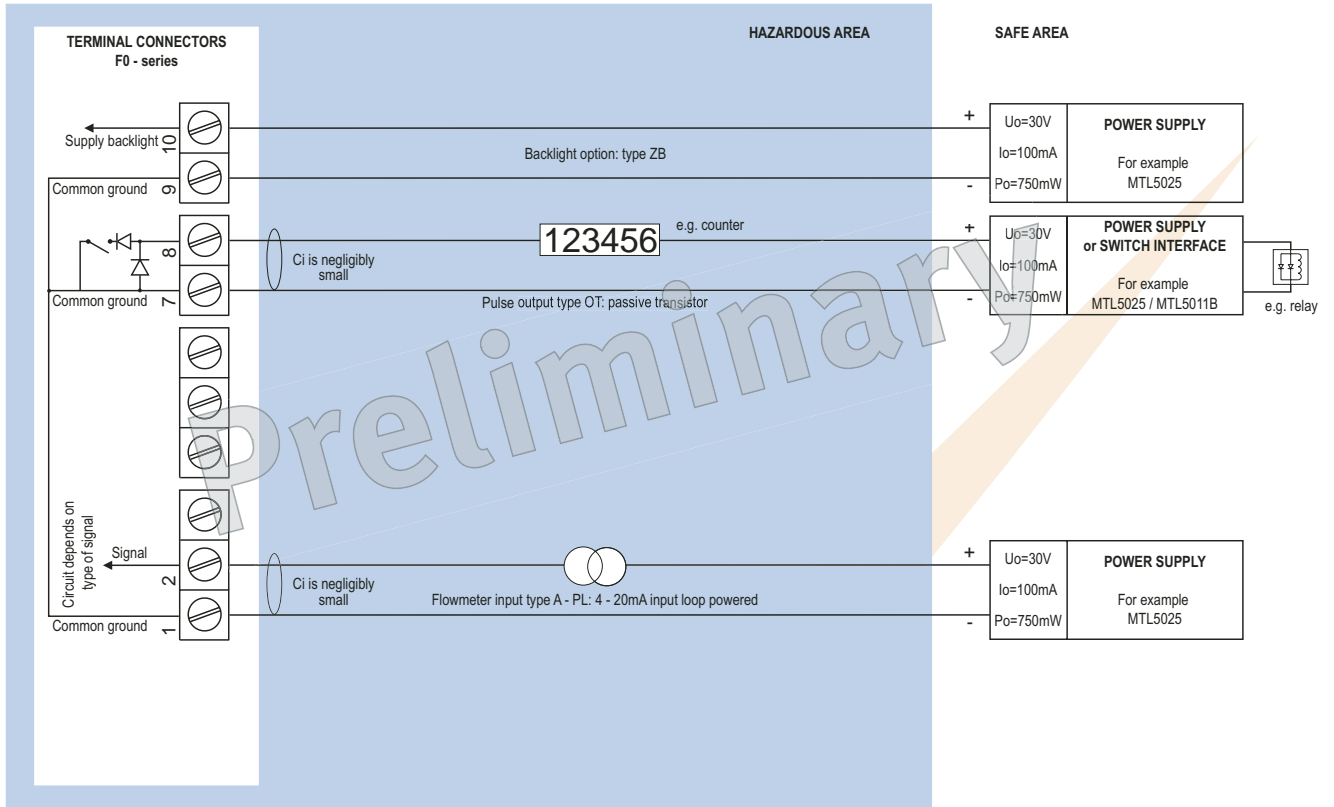

* Sensor supply is not available: unit is input loop powered.

Configuration example IIB and IIC - F016-A-OT-PX-XI-ZB - basic power supply 8 - 30V DC

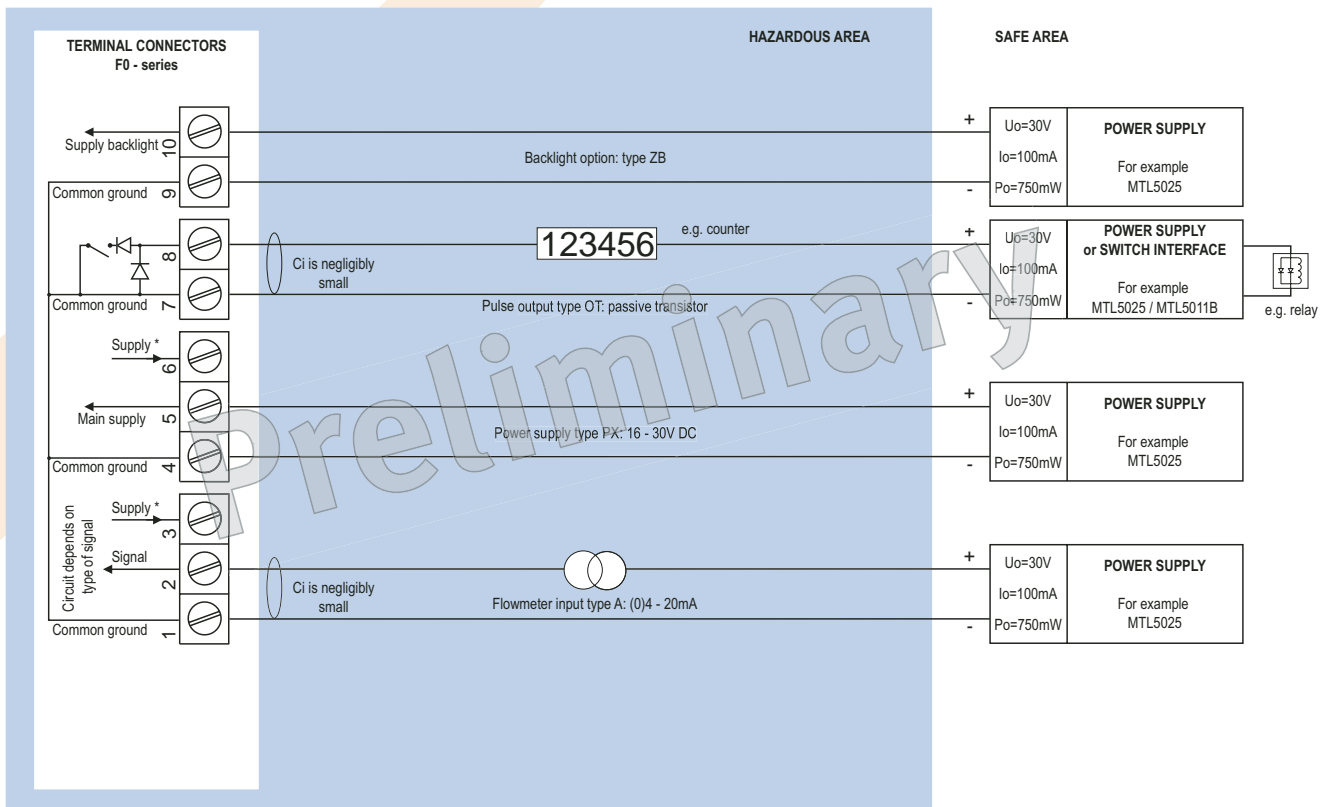

* Sensor supply voltage for pulse flowmeter type P: Terminal 3: 1.2 - 3.2V DC.

* Sensor supply voltage for analog flowmeter type A / U: Terminal 3: 3.2V DC.

Technical specification

General

Display	
Type	High intensity reflective numeric and alphanumeric LCD, UV-resistant.
Dimensions	90 x 40mm (3.5" x 1.6").
Digits	Seven 17mm (0.67") and eleven 8mm (0.31") digits. Various symbols and measuring units.
Refresh rate	User definable: 8 times/sec. - 30 secs - off.
Option ZB	Transflective LCD with bi-color LED-backlight; green / amber. Intensity and color selected through the keyboard. Good readings in full sunlight and darkness. Also available Intrinsically Safe.

Operating temperature

Standard unit	-40°C to +80°C (-40°F to +178°F).
Intrinsically Safe	-40°C to +70°C (-40°F to +158°F).

Power requirements

Type PB	Long life Lithium battery - life-time depends upon settings and configuration - up to 5 years.
Type PC	Intrinsically Safe long life lithium battery - life-time depends upon settings and configuration - up to 5 years.
Type PD	12 - 28V DC ± 10%. Intrinsically Safe 16 - 30V DC.
Type PF	24V AC / DC ± 10%.
Type PL	Input loop powered from sensor signal 4 - 20mA (type "A").
Type PM	115 - 230V AC ± 10%.
Type PX	8 - 28V DC ± 10% (limited sensor supply voltage).
Note	PB, PF and PM are not available Intrinsically Safe.

Sensor excitation

Type PB/PC/PX	3.2V DC for pulse signals and 1.2V DC for coil pick-up.
Type PD	for pulse signals: 1.2 - 3.2 - 8.2V DC - max. 5mA@8.2V DC. For analog signals, the sensor supply voltage will be according to power supply voltage (as connected to terminal 5).
Type PF / PM	1.2 - 3.2 - 8.2 - 12 and 24V DC - max. 200mA@24V DC.

Terminal connections

Type	Removable plug-in terminal strip. Wire max. 1.5mm ² and 2.5mm ² .
------	--

Data protection

Type	EEPROM backup of all settings. Backup of running totals every minute. Data retention at least 10 years.
Pass-code	Configuration settings can be pass-code protected.

Casing

General

Window	Polycarbonate window.
Sealing	EPDM and PE.
Control keys	Three industrial micro-switch keys. UV-resistant polyester keypad.

Aluminum field enclosures

General	Die-cast aluminum field mount enclosure IP67 / NEMA 4X with 2-component UV-resistant coating.
Dimensions	130 x 114 x 58mm (5.1" x 4.5" x 2.28") - W x H x D.
Weight	950 gr.
Type HA	Cable entry: 2 x PG9 and 1 x M20 tapped hole in the centre.
Type HT	Cable entry: 1 x 1/2" NPT tapped hole in the centre.
Type HU	Cable entry: 3 x 1/2" NPT tapped hole.
Type HZ	Cable entry: none, user defined.

ABS wall mount enclosures

General	ABS wall mount enclosure IP67 / NEMA 4X, UV-resistant and flame retardant.
Dimensions	130 x 114 x 71mm (5.1" x 4.5" x 2.8") - W x H x D.
Weight	400 gr.
Type HD	Cable entry: none, user defined.
Type HF	Cable entry: 1x 22mm (0.866") hole in the centre.

Panel mount enclosures

Type HB	Die-cast aluminum panel mount enclosure IP65 / NEMA 4.
Dimensions	130 x 114 x 50mm (5.1" x 4.5" x 1.97") - W x H x D.
Panel cut-out	115 x 96mm (4.53" x 3.78") L x H.
Weight	525 gr.
Type HC	ABS panel mount enclosure IP65 / NEMA 4, UV-resistant and flame retardant.
Dimensions	130 x 114 x 48mm (5.1" x 4.5" x 1.89") - W x H x D.
Panel cut-out	115 x 96mm (4.53" x 3.78") L x H.
Weight	300 gr.

Hazardous area

Intrinsically safe

ATEX / IECEx certification	Pending.
CSA C-US certification	Pending.
Ambient	-40°C to +70°C / -40° to +158°F.

Explosion proof

ATEX certification	II 2G EEx d IIB T5.
Type XF	Dimensions of enclosure: 350 x 250 x 200mm (13.78" x 9.84" x 7.87") L x H x D.
Weight	16 Kg.

Environment

Electromagnetic compatibility	Compliant ref: EN 61326 (1997), EN 61010-1 (1993).
-------------------------------	--

Signal input

Flowmeter sensor	
Type P	Coil / sine wave (minimum 20mVpp or 80mVpp - sensitivity selectable), NPN/PNP, open collector, reed-switch, Namur, active pulse signals 8 - 12 and 24V DC.
Frequency	Minimum 0Hz - maximum 7kHz for total and flowrate. Maximum frequency depends on signal type and internal low-pass filter. E.g. reed switch with low-pass filter: max. frequency 120Hz.
K-Factor	0.000010 - 9,999,999 with variable decimal position.
Low-pass filter	Available for all pulse signals.
Option ZF	coil sensitivity 10mVpp.
Option ZG	coil sensitivity 5mVpp.
Type A	(0)4 - 20mA. Analog input signal can be scaled to any desired range within 0 - 20mA.
Type U	0 - 10V DC. Analog input signal can be scaled to any desired range within 0 - 10V DC.
Accuracy	14 bit. Error < 0.05%. Low level cut-off programmable.
Span	0.000010 - 9,999,999 with variable decimal position.
Offset	0.000 - 9,999.999 units.
Update time	Four times per second.
Voltage drop	Type A: 2.6V@20mA.
Load impedance	Type U: 3kΩ.
Relationship	Linear and square root calculation.
Note	For signal type A and U: external power to sensor is required; e.g. type PD.

Signal output

Pulse output	
Function	Pulse output - transmitting accumulated total.
Type OA	One active 24V DC transistor output (PNP); load max. 200mA (requires PF or PM).
Type OR	One electro-mechanical relay output - isolated; max. switch power 230V AC (N.O.) - 0.5A (requires PF or PM).
Type OT	One passive transistor output (NPN) - not isolated.
Load	Max. 50V DC - 300mA per output.
Pulse output	Max. frequency 500Hz. Pulse length user definable between 1msec up to 10 seconds.

Operational

Operator functions	
Displayed functions	<ul style="list-style-type: none"> Linearised flowrate and / or total. Linearised total and accumulated total. Total can be reset to zero by pressing the CLEAR-key twice.

Total	
Digits	7 digits.
Units	L, m3, GAL, USGAL, KG, lb, bbl, no unit.
Decimals	0 - 1 - 2 or 3.
Note	Total can be reset to zero.

Accumulated total	
Digits	11 digits.
Units / decimals	According to selection for total.
Note	Can not be reset to zero.

Flowrate	
Digits	7 digits.
Units	mL, L, m3, Gallons, KG, Ton, lb, bl, cf, RND, ft3, scf, Nm3, NI, igal - no units.
Decimals	0 - 1 - 2 or 3.
Time units	/sec - /min - /hr - /day.

Display example - 90 x 40mm (3.5" x 1.6")



Ordering information

Example (standard configuration)

F016-P-HC-OT-PX-XX-ZX.

Explanation standard configuration:

P: flowmeter signal: pulse; **HC:** ABS panel mount enclosure; **OT:** passive transistor output;
PX: the unit is powered with 8 - 28V DC (basic power supply); **XX:** Safe area; **ZX:** no options.

ordering information:	F016	-	-H	-O	-P	-X	-Z
Flowmeter Sensor input signal							
A	⊗ (0)4 - 20mA input.						
P	⊗ Pulse input: coil, npn, pnp, namur, reed-switch.						
U	⊗ 0 - 10V DC input.						
Enclosure							
HA	⊗ Aluminum field mount enclosure IP67 / NEMA 4X - two holes PG9 + one hole M20.						
HB	⊗ Aluminum panel mount enclosure IP65 / NEMA 4.						
HC	⊗ ABS panel mount enclosure IP65 / NEMA 4.						
HD	⊗ ABS wall mount enclosure IP67 / NEMA 4X.						
HF	⊗ ABS wall mount enclosure IP67 / NEMA 4X - 1x hole 22mm.						
HT	⊗ Aluminum field mount enclosure IP67 / NEMA 4X - one hole 1/2"NPT.						
HU	⊗ Aluminum field mount enclosure IP67 / NEMA 4X - three holes 1/2"NPT.						
HZ	⊗ Aluminum field mount enclosure IP67 / NEMA 4X - no holes.						
Output							
OA	One active transistor output - requires PF or PM.						
OR	One mechanic relay output - requires PF or PM.						
OT	⊗ One passive transistor output - standard configuration.						
Power supply							
PB	Lithium battery powered.						
PC	⊗ Lithium battery powered - Intrinsically Safe.						
PD	⊗ 12 - 24V DC + sensor supply - with XI: 16 - 30V DC.						
PF	24V AC / DC + sensor supply.						
PL	⊗ Input loop powered from sensor signal type "A".						
PM	115 - 230V AC + sensor supply.						
PX	⊗ Basic power supply 8 - 28V DC (no real sensor supply).						
Hazardous area							
XI	⊗ Intrinsically safe.						
XF	⊗ EExd enclosure - 3 keys.						
XX	Safe area only.						
Other options							
ZB	⊗ Backlight.						
ZF	⊗ Coil input 10mVpp.						
ZG	⊗ Coil input 5mVpp.						
ZX	⊗ No options.						

The bold marked text contains the standard configuration.

⊗ Available Intrinsically Safe from november 2005.

Specifications are subject to change without notice.

FLUIDWELL bv
P.O. Box 6
5460 AA - Veghel - The Netherlands
Tel.: +31 (0)413 343786
Fax.: +31 (0)413 363443
sales@fluidwell.com
Internet: www.fluidwell.com

