



DIFFERENTIAL FLOW COMPUTER

WITH TEMPERATURE COMPENSATION FOR
CORRECTED LIQUID VOLUME



Features

- Displays compensated consumption (flowrate), total and accumulated total.
- Supply line: displays temperature and compensated flowrate.
- Return line: displays temperature and compensated flowrate.
- 7 digit resettable total.
- 11 digit accumulated total.
- Analog signal output.
- Very compact design for panel mount, wall mount or field mount applications.
- Operational temperature -30°C up to +80°C (-22°F up to 178°F).
- Rugged aluminum field mount enclosure IP67/NEMA4X.
- Intrinsically safe
 II 1GD EEx ia IIB/IIC T4 T100°C.
- Explosion/flame proof  II 2G EEx d IIB T5.
- Full Modbus communication RS232 / 485 / TTL.
- Loop or battery powered, 8 - 24V AC/DC or 115 - 230V AC power supply.
- Sensor supply 3.2 - 8.2 - 12 - 24V DC.

Signal output

- (0)4 - 20mA / 0 - 10V DC according to compensated consumption (flowrate).

Signal input

Flow

- Reed-switch.
- NAMUR.
- NPN/PNP pulse.
- Coil (sine wave).
- Active pulse signals.

Temperature

- PT100 - 2 or 3 wire.
- (0)4 - 20mA.
- 0 - 10V DC.

Applications

- fuel consumption calculation for diesel engines on board of ships or locomotives, generators or burners.

General information

Introduction

The flowcomputer Model F127 has been developed to calculate corrected differential liquid volume. A typical application is the measurement of fuel consumption by engines for power generators, e.g. on board ships and locomotives. The usual difficulties encountered in such applications include: pulsating flows, very low consumption readings, vibration and high ambient temperatures. These are all well catered for in the design and operation of the F127. The corrected volumetric flow in each line is calculated using the thermal expansion coefficient algorithm stored in the flowcomputer. The reference temperature can be defined as desired, e.g. 15°C, 20°C or 60°F.

Display

The display has large 17mm (0.67") and 8mm (0.31") digits which can be set to show flowrate, total and temperature. On-screen engineering units are easily configured from a comprehensive selection. The accumulated total can register up to 11 digits and is backed-up in EEPROM memory every minute.

Configuration

All configuration settings are accessed via a simple operator menu which can be pass-code protected. Each setting is clearly indicated with an alphanumeric description, therefore avoiding confusing abbreviations and baffling codes. Once familiar with one F-series product, you will be able to program all models in the series without a manual. All settings are safely stored in EEPROM memory in the event of sudden power failure.

Analog output signal

The calculated consumption (flowrate) is re-transmitted with the (0)4 - 20mA or 0 - 10V DC output signal. The output signal is updated ten times per second with a filter function being available to smoothen out the signal if desired. The output value is user defined in relation to the flowrate, e.g. 4mA equals to 15L/Hr and 20mA equals to 2000L/Hr. The output signal can be passive, active or isolated where the passive output type will loop power the F127 as well.

Signal inputs

The flowcomputer measures the uncorrected volumetric flow and temperature in both supply and return line. The F127 will accept most pulse input signals for flow. For the temperature measurement, 2 or 3 wire PT100 elements or sensors with a (0)4 - 20mA / 0 - 10V DC output signal can be used.

Communication

All process data and settings can be read and modified manually or through the Modbus communication link (RS232 / RS485). Full Modbus functionality remains available for the Intrinsically Safe version (TTL).

Hazardous area

For hazardous area applications, this model has been ATEX certified intrinsically safe $\text{Ex} \text{II} \text{1GD} \text{EEx ia IIB/IIC T4 T100}^\circ\text{C}$ with an allowed operational temperature of -30°C to $+70^\circ\text{C}$ (-22°F to $+158^\circ\text{F}$). A flame proof enclosure is also available with the rating $\text{Ex} \text{II} \text{2G} \text{EEx d IIB T5}$.

Enclosures

Various types of enclosures can be selected, all ATEX approved. As standard the F127 is supplied in an ABS panel mount enclosure, which can be converted to an IP67 / NEMA 4X ABS field mount enclosure by the addition of a back case. Most popular is our rugged aluminum field mount enclosure with IP67 / NEMA 4X rating. Both European or U.S. cable gland entry threads are available.

Overview application F127

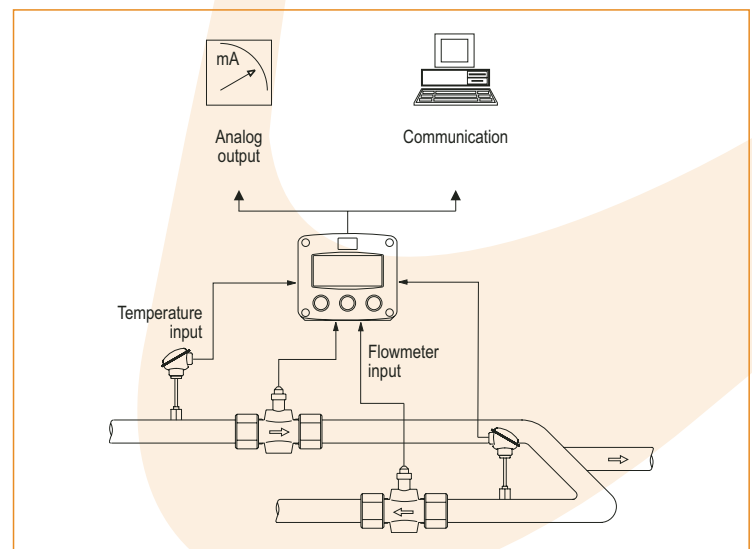

Typical wiring diagram F127-P-(AP)-CH-EL-TP-PB

Typical wiring diagram F127-P-AP-CH-EL-TA

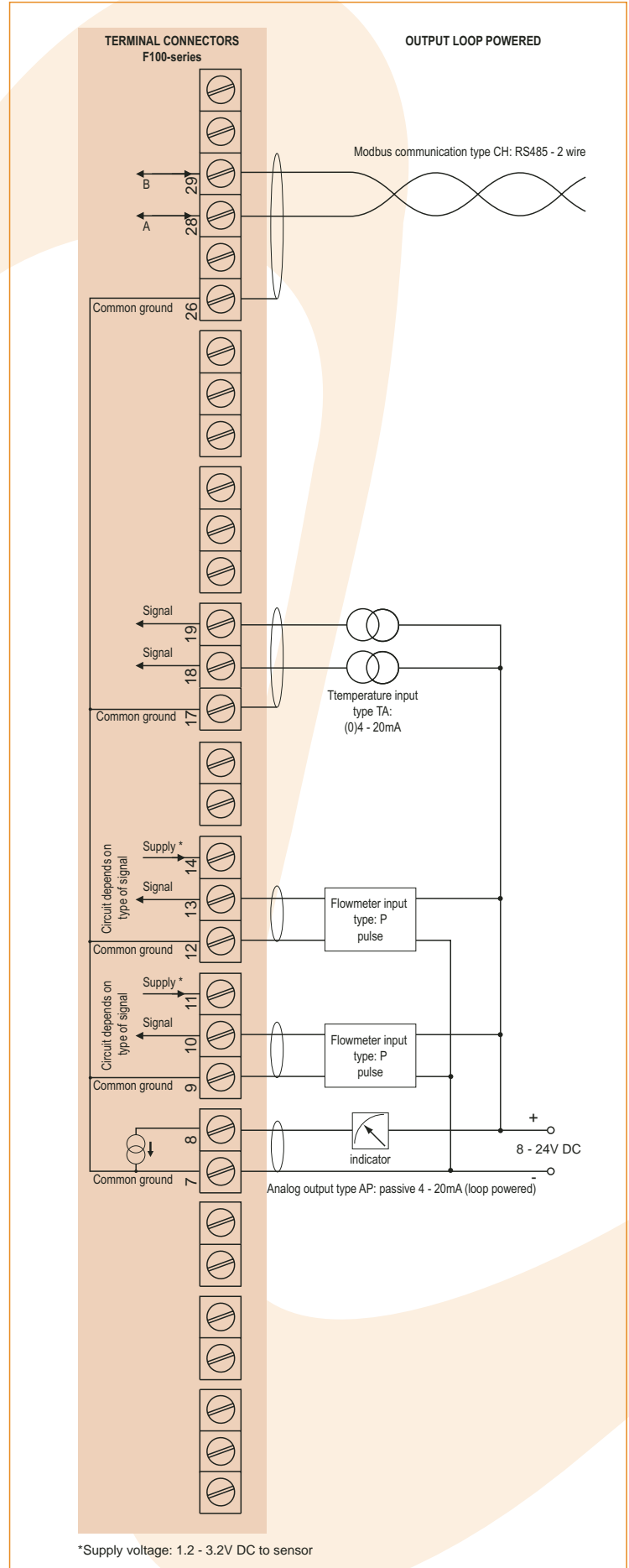
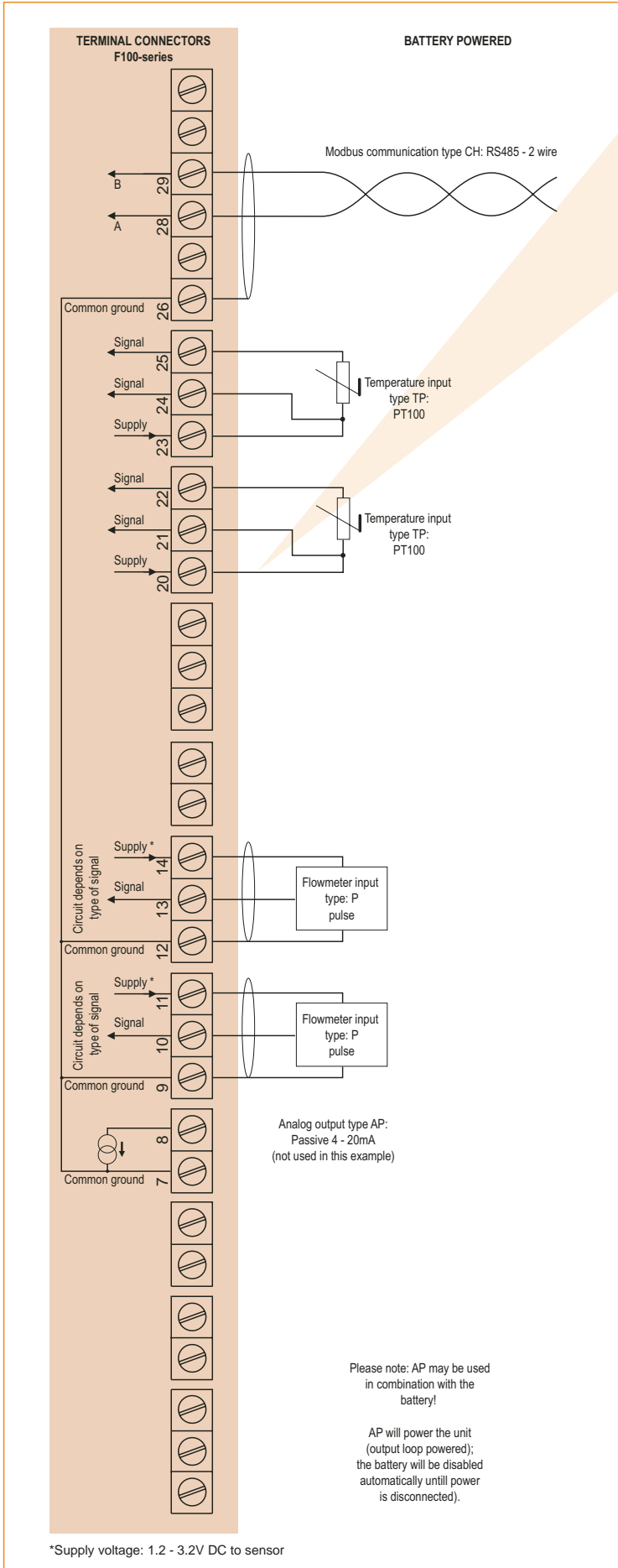

Typical wiring diagram F127-P-AI-CI-EL-TA-PD

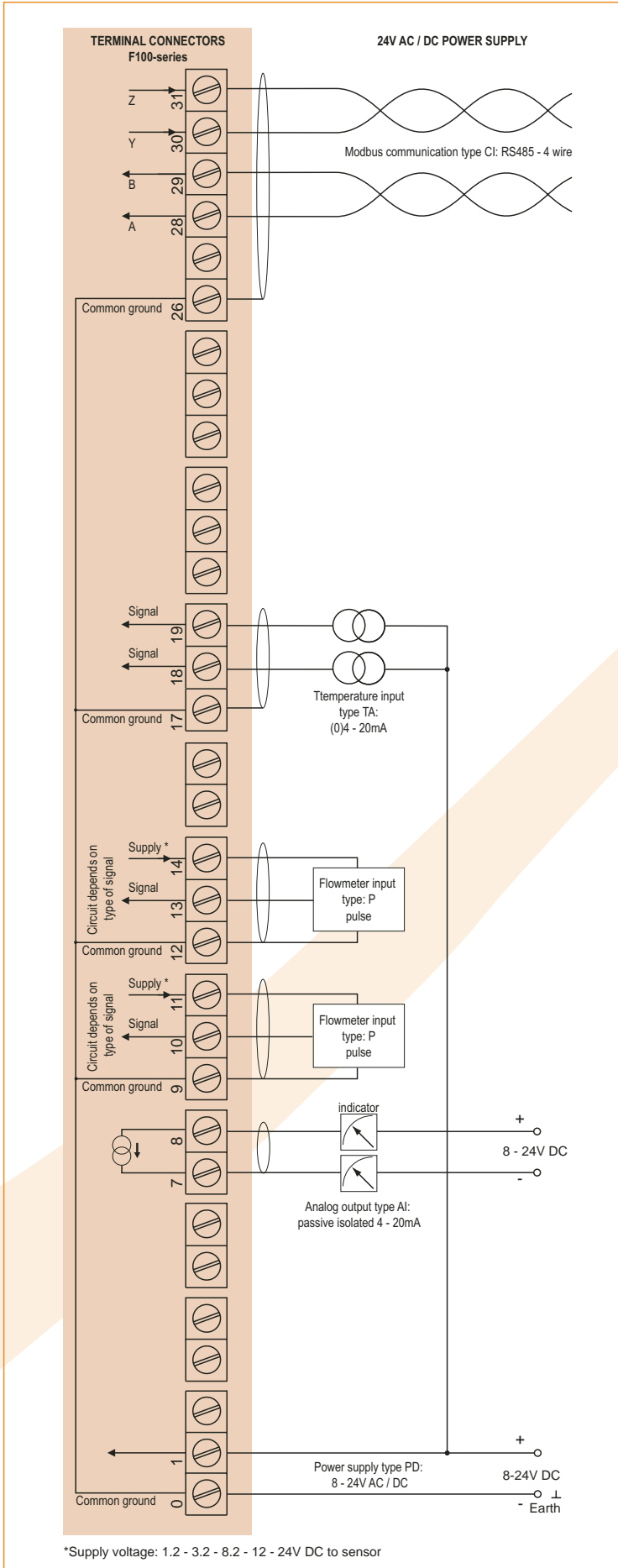

Typical wiring diagram F127-P-AA-CB-EL-PM-TP

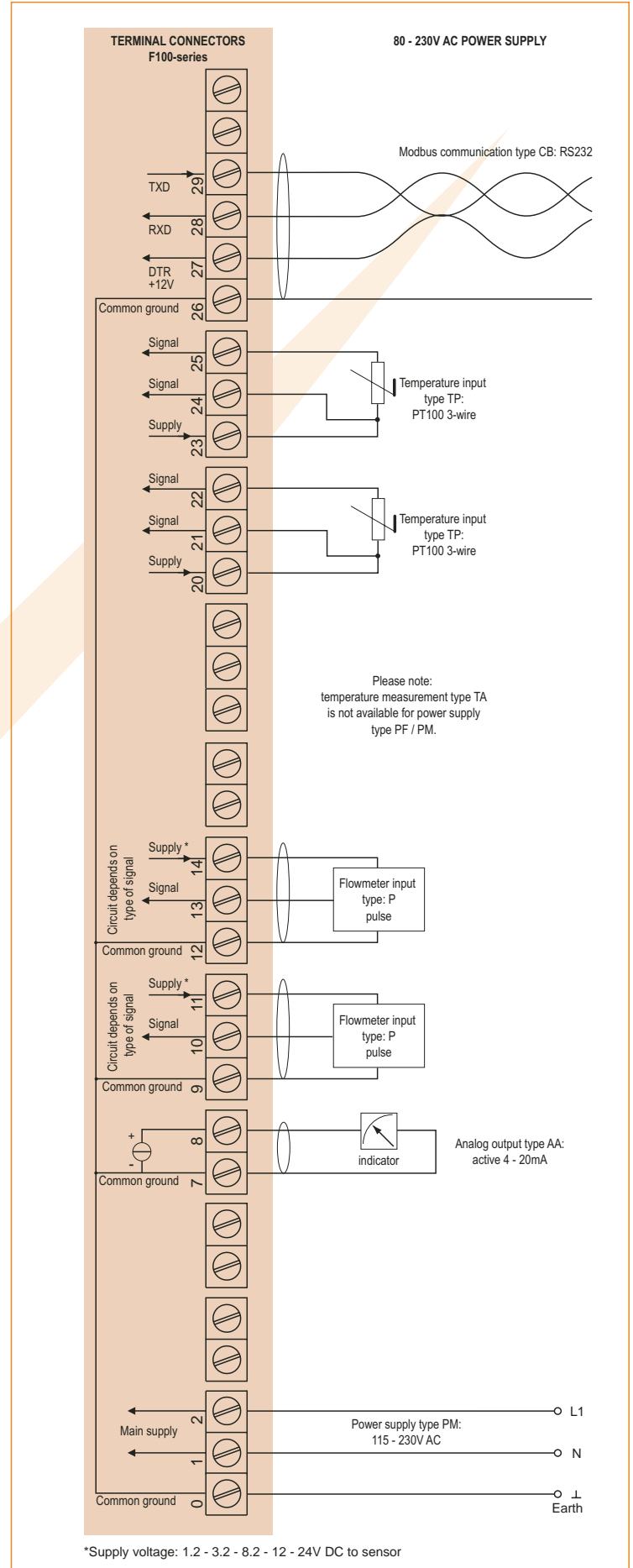

Hazardous area applications

The F127-XI has been ATEX approved by KEMA for use in intrinsically safe applications. It is approved according to $\text{Ex} \text{II} \text{1GD} \text{ EEx ia IIB/IIC T4 T100}^\circ\text{C}$ for gas and dust applications with an operational temperature range of -30°C to $+70^\circ\text{C}$ (-22°F to $+158^\circ\text{F}$). It is allowed to connect up to six I.S. power supplies in IIB applications or one I.S. power supply in IIC applications. Full functionality of the F127 remains available, including 4 - 20mA output according to the flowrate and Modbus communication (type CT).

Power supply type PD-XI offers a 8.2V sensor supply e.g. for two Namur sensors. A flame proof enclosure with rating $\text{Ex} \text{II} \text{2G} \text{ EEx d IIB T5}$ is available as well. Please contact your supplier for further details.

Certificate of conformity KEMA 03ATEX1074 X



Configuration example IIB and IIC

F127-P-(AP)-(CT)-EL-TP-PB-XI - battery powered unit

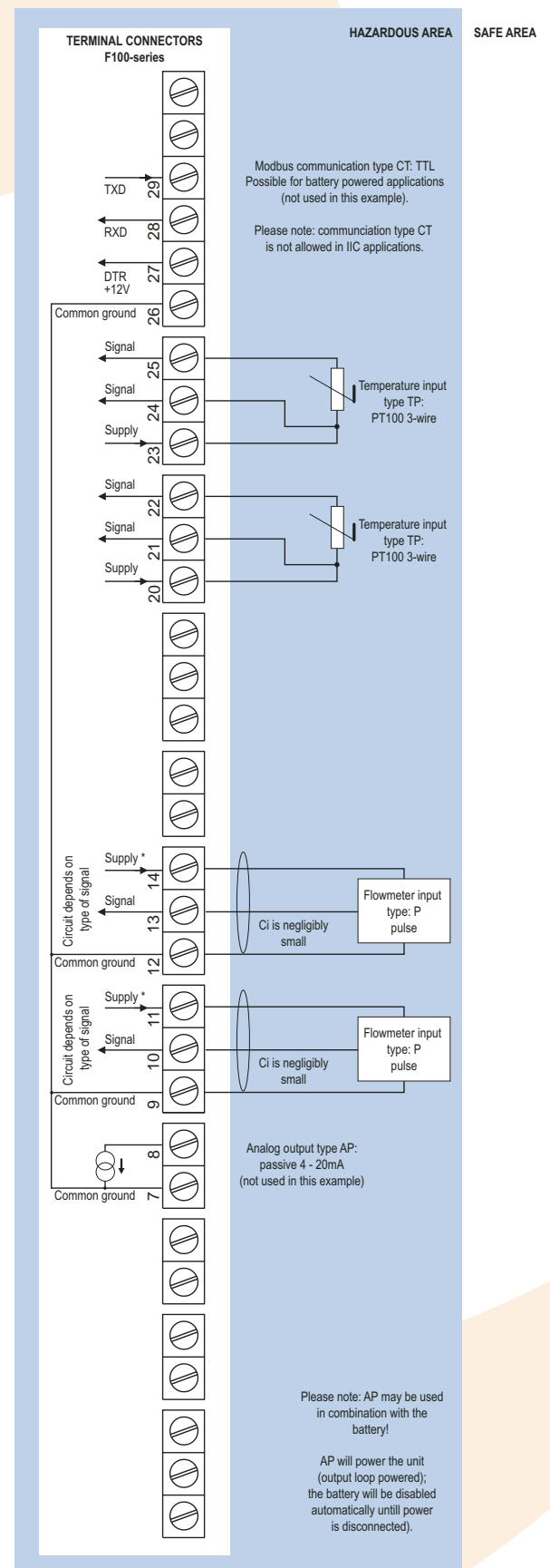

* Note sensor supply voltage: 1.2V DC for coil sensors or 3.2V DC for other pulse sensors.

Configuration example IIB and IIC - F127-P-AP-CT-EL-TP-XI - Output loop powered

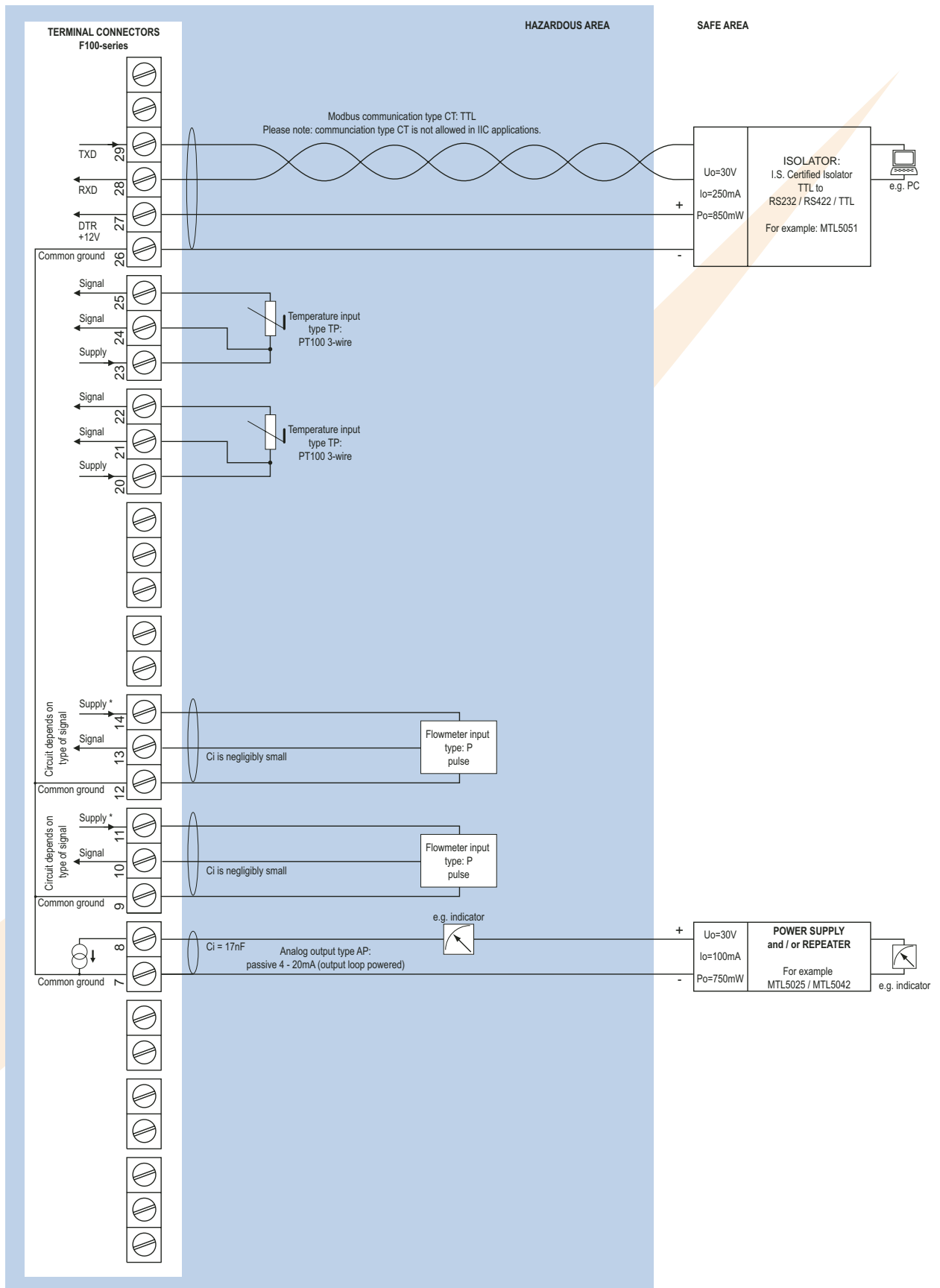

Configuration example IIB and IIC - F127-P-AF-CT-EL-PD-TA-XI - Power supply 16 - 30 V DC

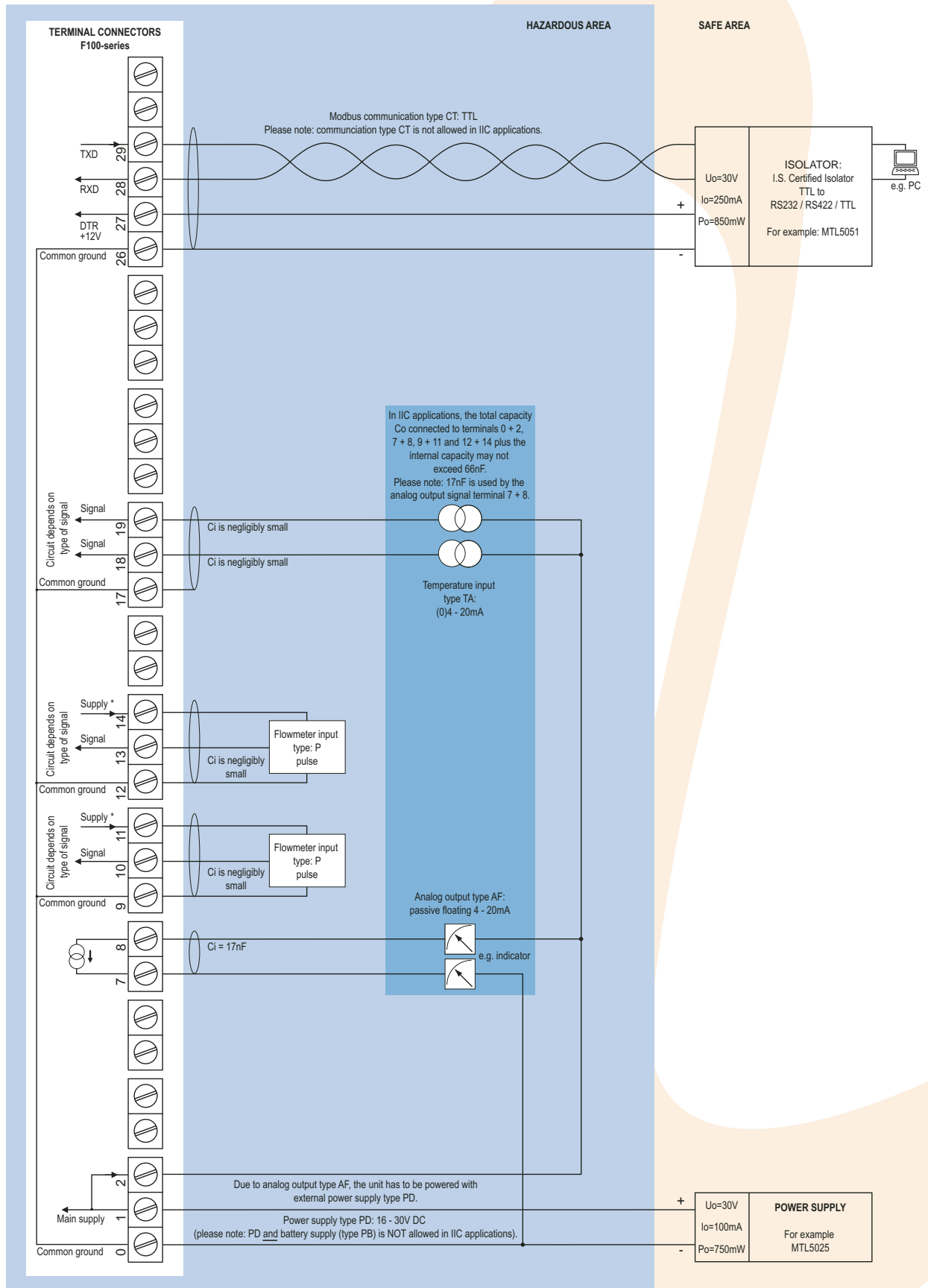

* Note power supply type PD: the supply voltage is maximum 8.7V (U_o=8.7V I_o=25mA P_o=150mW)

Configuration example IIB - F127-P-AF-CT-EL-PD-TA-XI - Power supply 16 - 30 V DC

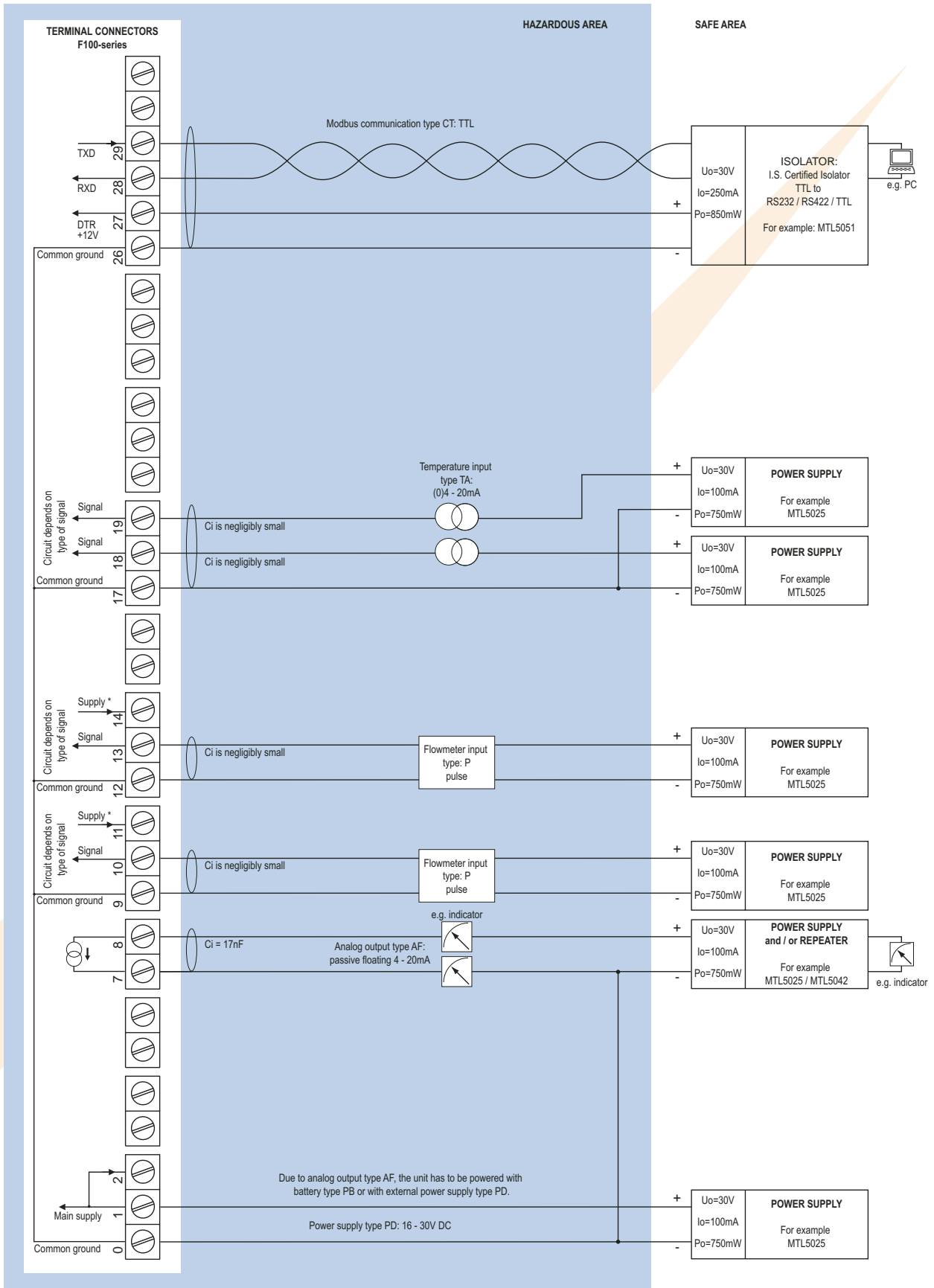

Technical specification

General

Display	
Type	High intensity reflective numeric and alphanumeric LCD, UV-resistant.
Dimensions	90 x 40mm (3.5" x 1.6").
Digits	Seven 17mm (0.67") and eleven 8mm (0.31") digits. Various symbols and measuring units.
Refresh rate	User definable: 8 times/sec. - 30 secs.
Option ZB	LED-backlight - available appr. Nov. 2004.

Casing	
Window	Polycarbonate window.
Sealing	EPDM and PE.
Control keys	Three industrial micro-switch keys. UV-resistant polyester keypad.
Type HA	Die-cast aluminum field mount enclosure IP67 / NEMA 4X with 2-component UV-resistant coating.
Dimensions	130 x 114 x 58mm (5.1" x 4.5" x 2.28") - W x H x D.
Cable Entry	2 x PG9 and 1 x M20 tapped hole in the centre.
Weight	950 gr.
Type HB	Die-cast aluminum panel mount enclosure IP65 / NEMA 4 with 2-component UV-resistant coating.
Dimensions	130 x 114 x 50mm (5.1" x 4.5" x 1.97") - W x H x D.
Panel cut-out	115 x 96mm (4.53" x 3.78") LxH.
Weight	525 gr.
Type HC	ABS panel mount enclosure IP65 / NEMA 4, UV-resistant and flame retardent.
Dimensions	130 x 114 x 48mm (5.1" x 4.5" x 1.89") - W x H x D.
Panel cut-out	115 x 96mm (4.53" x 3.78") LxH.
Weight	300 gr.
Type HD	ABS wall mount enclosure IP67 / NEMA 4X, UV-resistant and flame retardent.
Dimensions	130 x 114 x 71mm (5.1" x 4.5" x 2.8") - W x H x D.
Cable Entry	None, user defined.
Weight	400 gr.
Type HU	Die-cast aluminum field mount enclosure IP67 / NEMA 4X with 2-component UV-resistant coating.
Dimensions	5.1" x 4.5" x 2.28" - W x H x D.
Cable Entry	3 x 1/2" NPT tapped hole.
Weight	950 gr.



Operating temperature	
Operational	-30°C to +80°C (-22°F to +178°F).

Power supply	
Type PB	Long life Lithium battery - life-time depends upon settings and configuration - up to 5 years.
Type PD	8 - 24V AC/DC ± 10%.
Type PD-XI	16 - 30V DC (Intrinsically Safe).
Type PF	24V AC/DC ± 10%.
Type PM	115 - 230V AC ± 10%.
Type PX	8 - 28V DC output loop powered unit with analog output signal type AP (or 8 - 24 V AC/DC if type AP will not be used).
Note	PF and PM are only available with PT100 temperature sensors type TP.

Sensor excitation	
Type PB / PX	3.2V DC for pulse signals and 1.2V DC for coil pick-up.
Type PD	1.2 - 3.2 - 8.2 - 12 and 24V DC - max. 50mA@24V DC.
Type PD-XI	1.2 - 3.2 - 8.2V DC - max. 7mA@8.2V DC and mains power supply voltage (as connected to terminal 1).
Type PF / PM	1.2 - 3.2 - 8.2 - 12 and 24V DC - max. 200mA@24V DC.

Terminal connections	
Type	Removable plug-in terminal strip. Wire max. 1.5mm ² and 2.5mm ² .

Data protection	
Type	EEPROM backup of all settings. Backup of running totals every minute. Data retention at least 10 years.
Pass-code	Configuration settings can be pass-code protected.

Hazardous area	
Intrinsically safe	ATEX approval ref:  II 1GD EEx ia IIB/IIC T4 T100°C
Type XI	CSA/FM pending. Maximum ambient +70°C (158°F).
Explosion proof	ATEX approval ref:  II 2G EEx d IIB T5
Type XD/XF	Dimensions of enclosure: 218 x 418 x 210mm (8.58" x 16.45" x 8.38") W x H x D.
Weight	16 Kg.

Environment	
Electromagnetic compatibility	Compliant ref: EN 61326 (1997), EN 61010-1 (1993).

Signal inputs

Flowmeter	
Type P	Coil / sine wave (minimum 20mVpp or 80mVpp - sensitivity selectable), NPN/PNP, open collector, reed-switch, Namur, active pulse signals 8, 12 and 24V DC.
Frequency	Minimum 0 Hz - maximum 7 kHz for total and flowrate. Maximum frequency depends on signal type and internal low-pass filter. E.g. reed switch with low-pass filter: max. frequency 120 Hz.
K-Factor	0.000010 - 9,999,999 with variable decimal position.
Low-pass filter	Available for all pulse signals.
Option ZF	coil sensitivity 10mVpp.

Temperature

Accuracy	14 bit. Error < 0.05%. Low level cut-off programmable.
Update time	Four times per second.
Type TA	(0)4 - 20mA. Analog input signal can be scaled to any desired range within 0 - 20mA.
Span	0.000010 - 9,999,999 with variable decimal position.
Offset	0.00 - 99,999.99 K.
Voltage drop	2.5V@20mA.
Type TP	2 or 3 wire PT100.
Range	-100°C to +200°C (-148°F to 392°F). Accuracy 0.1°C (0.18°F).
Option ZV	Range: -200°C to +800°C (-328°F to 1832°F). Accuracy 0.5°C (0.9°F).
Type TU	0 - 10 V DC. Analog input signal can be scaled to any desired range within 0 - 10V DC.
Span	0.000010 - 9,999,999 with variable decimal position.
Offset	0.00 - 99,999.99 K.
Load impedance	3kΩ.
Note 1	TA / TU are not available for PF and PM.
Note 2	For signal TA and TU: power supply to temperature sensor is required; e.g. PD.

Signal outputs

Analog output

Function	Transmitting compensated differential flowrate.
Accuracy	10 bit. Error < 0.05%. Analog output signal can be scaled to any desired range.
Update time	Ten times per second.
Type AA	Active 4 - 20mA output (requires PD, PF or PM).
Type AB	Active 0 - 20mA output (requires PD, PF or PM).
Type AF	Passive floating 4 - 20mA output for Intrinsically Safe applications (requires PB or PD).
Type AI	Passive galvanically isolated 4 - 20mA output - also available for battery powered models (requires PB, PD, PF or PM).
Type AP	passive 4 - 20mA output - not isolated. Unit will be loop powered.
Type AU	Active 0 - 10V DC output (requires PD, PF or PM).

Communication

Functions	Reading display information, reading / writing all configuration settings.
Type CB	RS232
Type CH	RS485 2-wire
Type CI	RS485 4-wire
Type CT	TTL Intrinsically Safe.
Protocol	Modbus RTU.
Speed	1200 - 2400 - 4800 - 9600 baud.
Addressing	Maximum 255 addresses.

Operational

Operator functions

Displayed function	<ul style="list-style-type: none"> Compensated differential flowrate (consumption). Compensated differential total and accumulated total. Supply line - Inlet temperature and compensated flowrate. Return line - Outlet temperature and compensated flowrate. Total can be reset to zero by pressing the CLEAR-key twice.
--------------------	---

Total

Digits	7 digits.
Units	L, m3, GAL, USGAL, KG, lb, bbl, no unit.
Decimals	0 - 1 - 2 or 3.
Note	Total can be reset to zero.

Accumulated total

Digits	11 digits.
Units / decimals	According to selection for total.
Note	Can not be reset to zero.

Flowrate

Digits	7 digits.
Units	mL, L, m3, Gallons, KG, Ton, lb, bl, cf, RND, ft3, scf, Nm3, NL, ical - no units.
Decimals	0 - 1 - 2 or 3.
Time units	/sec - /min - /hr - /day.

Line temperature

Digits	6 digits.
Units	°C, °F or K.
Decimals	1.

Flow equations

Type EL	Corrected liquid volume.
Formula	$Q_{normal} = Q \times (1 + \alpha (T_{normal} - T))$ where α = thermal expansion coefficient.
Normal temperature	Default: 273.15 K - any temperature can be set.

Display example - 90 x 40mm (3.5" x 1.6")



Ordering information

Example (standard configuration)

F127-P-AP-CX-EL-HC-PX-TA-XX-ZX.

Explanation standard configuration:

P: flowmeter signal: pulse; AP: passive 4 - 20mA analog output; CX: no communication; EL: equations corrected liquid volume; HC: ABS panel mount enclosure; PX: the unit is powered by the analog output loop, type AP: 8 - 28V DC (or AC); TA: (0)4 - 20mA temperature inputs; XX: Safe area; ZX: no options.

Ordering information:	F127	-P	-A	-C	-EL	-H	-P	-T	-X	-Z
Flowmeter input signal										
P	⊗	Pulse: coil, npn, pnp, namur, reed-switch input.								
Analog output signal										
AA		Active 4 - 20mA output - requires PD, PF or PM.								
AB		Active 0 - 20mA output - requires PD, PF or PM.								
AF	⊗	I.S. floating 4 - 20mA output - requires PB or PD.								
AI		Isolated 4 - 20mA output - requires PB, PD, PF or PM.								
AP	⊗	Passive 4 - 20mA output, loop powered unit.								
AU		Active 0 - 10V DC output - requires PD, PF or PM.								
Communication										
CB		Communication RS232 - Modbus RTU.								
CH		Communication RS485 - 2-wire - Modbus RTU.								
CI		Communication RS485 - 4-wire - Modbus RTU.								
CT	⊗	Intrinsically Safe TTL - Modbus RTU.								
CX	⊗	No communication.								
Flow equation										
EL	⊗	Corrected liquid volume.								
Enclosure										
HA	⊗	Aluminum field mount enclosure IP67 / NEMA 4X.								
HB	⊗	Aluminum panel mount enclosure IP65 / NEMA 4.								
HC	⊗	ABS panel mount enclosure IP65 / NEMA 4.								
HD	⊗	ABS wall mount enclosure IP67 / NEMA 4X.								
HU	⊗	Aluminum field mount enclosure IP67 / NEMA 4X.								
Power supply										
PB	⊗	Lithium battery powered.								
PD	⊗	8 - 24V AC/DC + sensor supply - in combination with XI: 16 - 30V DC.								
PF		24V AC/DC + sensor supply - only available with TP.								
PM		115 - 230V AC + sensor supply - only available with TP.								
PX	⊗	No power supply option. Unit requires external loop AP.								
Temperature input signal										
TA	⊗	(0)4 - 20mA input.								
TP	⊗	PT100 input.								
TU	⊗	0 - 10V DC input.								
Hazardous area										
XI	⊗	Intrinsically safe.								
XD	⊗	EExd enclosure - 1 key.								
XF	⊗	EExd enclosure - 3 keys.								
XX		Safe area only.								
Options										
ZB	⊗	Backlight (available appr. Nov. 2004).								
ZF	⊗	Coil input 10mVpp.								
ZV	⊗	PRTD-range -200°C / +800°C.								
ZX	⊗	No options.								

The bold marked text contains the standard configuration.

⊗ Available Intrinsically Safe.

Specifications are subject to change without notice.

FLUIDWELL bv
P.O. Box 6
5460 AA - Veghel - The Netherlands
Tel.: +31 (0)413 343786
Fax.: +31 (0)413 363443
sales@fluidwell.com
Internet: www.fluidwell.com

