

# FLOWCOMPUTER

WITH TEMPERATURE AND PRESSURE  
COMPENSATION FOR CORRECTED GAS VOLUME



## Features

- Calculates compensated flowrate, total and accumulated total.
- Displays actual line pressure and temperature.
- Selectable on-screen engineering units; volumetric or mass.
- 7 digit resettable total.
- 11 digit accumulated total.
- Analog signal output.
- Very compact design for panel mount, wall mount or field mount applications.
- Operational temperature -30°C up to +80°C (-22°F up to 178°F).
- Rugged aluminum field mount enclosure IP67/NEMA4X.
- Intrinsically safe  
⊕ II 1GD EEx ia IIB/IIC T4 T100°C.
- Explosion/flame proof ⊕ II 2G EEx d IIB T5.
- Full Modbus communication RS232/485/TTL.
- Loop or battery powered, 8 - 24V AC/DC or 115 - 230V AC power supply.

## Signal output

- (0)4 - 20mA / 0 - 10V DC according to compensated flowrate.

## Signal input

### Flow

- Reed-switch.
- NAMUR.
- NPN/PNP pulse.
- Coil (sine wave).
- Active pulse signals.
- (0)4 - 20mA.
- 0 - 10V DC.

### Temperature

- PT100 - 2 or 3 wire.
- (0)4 - 20mA.
- 0 - 10V DC.

### Pressure

- (0)4 - 20mA.
- 0 - 10V DC.

## Applications

- applications where nett gas flow calculation at base conditions is desired.

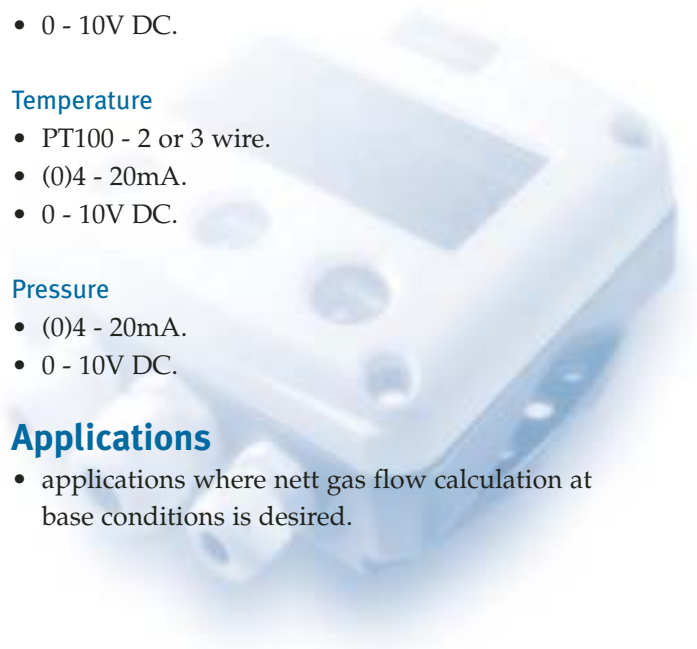

## General information

### Introduction

The flowcomputer Model F126-EG has been developed to calculate the gas volume at normal conditions, in most cases at 0°C (32 °F) and 1.013 Bar. If desired, any other temperature or pressure can be set. The corrected volumetric flow is calculated using the equations stored in the flowcomputer while a compressibility factor can be set to approach a real gas behaviour. A wide selection of options further enhance this models capabilities, including intrinsic safety and full Modbus communication.

### Display

The display has large 17mm (0.67") and 8mm (0.31") digits which can be set to show flowrate, total, temperature and pressure. On-screen engineering units are easily configured from a comprehensive selection. The accumulated total can register up to 11 digits and is backed-up in EEPROM memory every minute.

### Configuration

All configuration settings are accessed via a simple operator menu which can be pass-code protected. Each setting is clearly indicated with an alphanumeric description, therefore avoiding confusing abbreviations and baffling codes. Once familiar with one F-series product, you will be able to program all models in the series without a manual. All settings are safely stored in EEPROM memory in the event of sudden power failure.

### Analog output signal

The calculated flowrate is re-transmitted with the (0)4 - 20mA or 0 - 10V DC output signal. The output signal is updated ten times per second with a filter function being available to smoothen out the signal if desired. The output value is user defined in relation to the flowrate, e.g. 4mA equals to 15Nm<sup>3</sup>/Hr and 20mA equals to 2000Nm<sup>3</sup>/Hr. The output signal can be passive, active or isolated where the passive output type will loop power the F126-EG as well.

### Signal input

The flowcomputer measures the uncorrected volumetric flow, line temperature and pressure. The F126-EG will accept most pulse and analog input signals for flow. For the temperature measurement, 2 or 3 wire PT100 elements or sensors with a (0)4 - 20mA / 0 - 10V DC output signal can be used, just as for the pressure measurement.

### Communication

All process data and settings can be read and modified manually or through the Modbus communication link (RS232 / RS485). Full Modbus functionality remains available for the Intrinsically Safe version (TTL).

### Hazardous areas

For hazardous area applications, this model has been ATEX certified intrinsically safe  $\text{Ex II 1GD EEx ia IIB / IIC T4 T100}^{\circ}\text{C}$  with an allowed operational temperature of  $-30^{\circ}\text{C}$  to  $+70^{\circ}\text{C}$  ( $-22^{\circ}\text{F}$  to  $+158^{\circ}\text{F}$ ). A flame proof enclosure is also available with the rating  $\text{Ex II 2G EEx d IIB T5}$ .

### Enclosures

Various types of enclosures can be selected, all ATEX approved. As standard the F126-EG is supplied in an ABS panel mount enclosure, which can be converted to an IP67 / NEMA 4X ABS field mount enclosure by the addition of a back case. Most popular is our rugged aluminum field mount enclosure with IP67 / NEMA 4X rating. Both European or U.S. cable gland entry threads are available.

## Overview application F126-EG

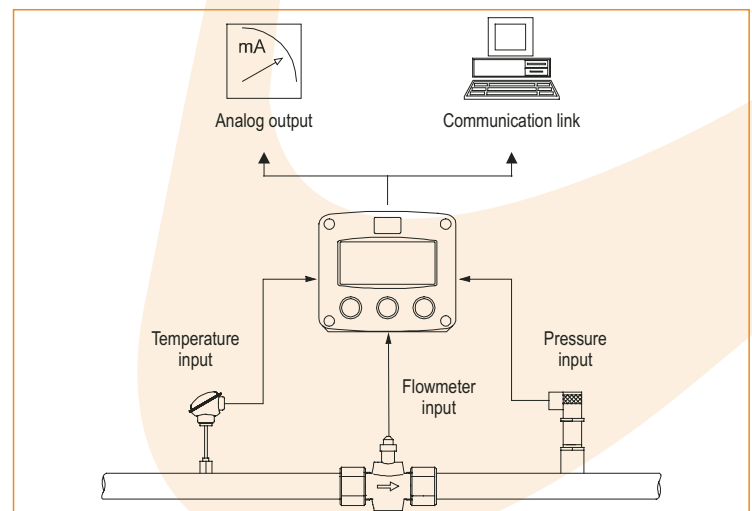

## Dimensions enclosures

### Enclosure HA

#### Aluminum field mount enclosure

#### IP67 / NEMA 4X

Tapped holes: European thread

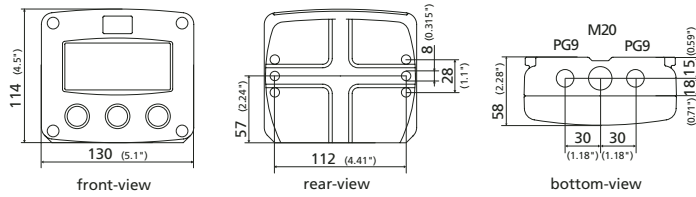

### Enclosure HB

#### Aluminum panel mount enclosure

#### IP65 / NEMA 4

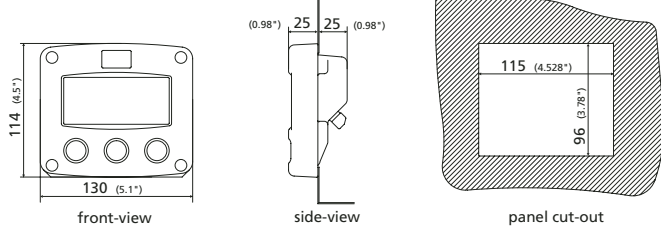

### Enclosure HC (standard)

#### ABS panel mount enclosure

#### IP65 / NEMA 4

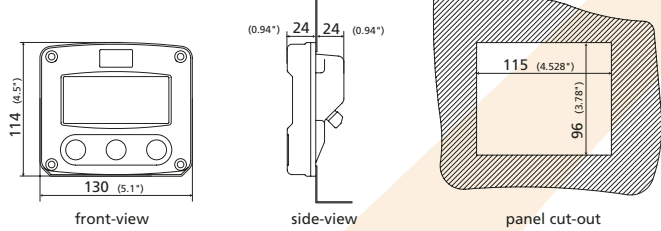

### Enclosure HD

#### ABS wall mount enclosure

#### IP67 / NEMA 4X

Holes user defined

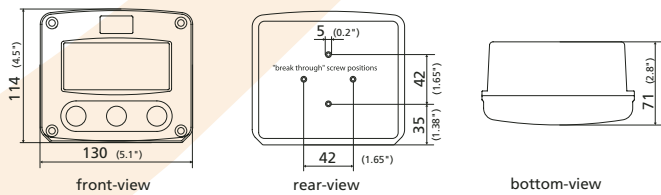

### Enclosure HU

#### Aluminum field mount enclosure

#### IP67 / NEMA 4X

Tapped holes: U.S. thread

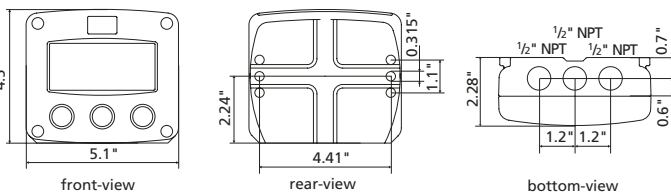

## Terminal connections

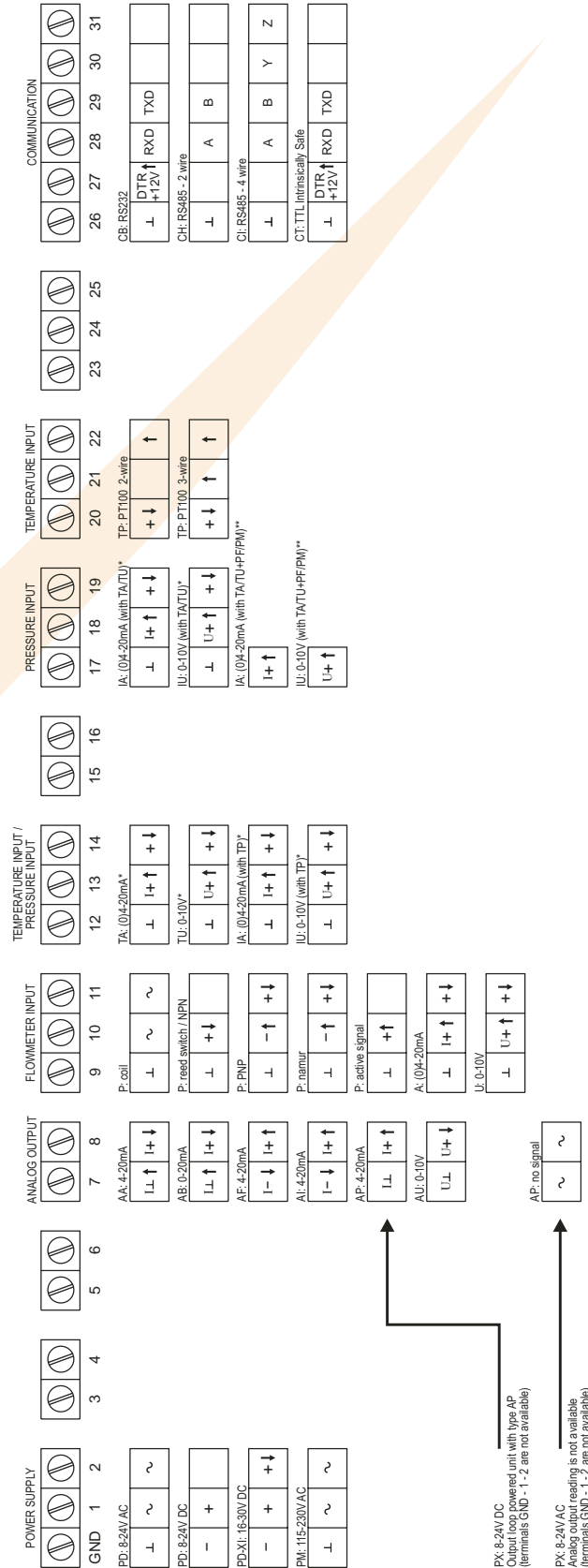

\* Note: If TATU is used then IA/IU use terminal 17 - 18 - 19.

If TP is used then IA/IU use terminal 12 - 13 - 14.

\*\* Note: If PFI/PW and TATU is used then IA/IU use terminal 17 only.

PX: 8-24V DC  
Output loop powered unit with type AP  
(terminals GND - 1, -2 are not available)

PY: 8-24V AC  
Analog output reading is not available  
(terminals GND - 1, -2 are not available)

PZ: battery powered  
Internal long life Lithium battery  
(terminals GND - 1, -2 are not available)

Typical wiring diagram F126-P-AP-CH-EG-IA-TA

Typical wiring diagram F126-P-AI-CI-EG-IA-TA-PD

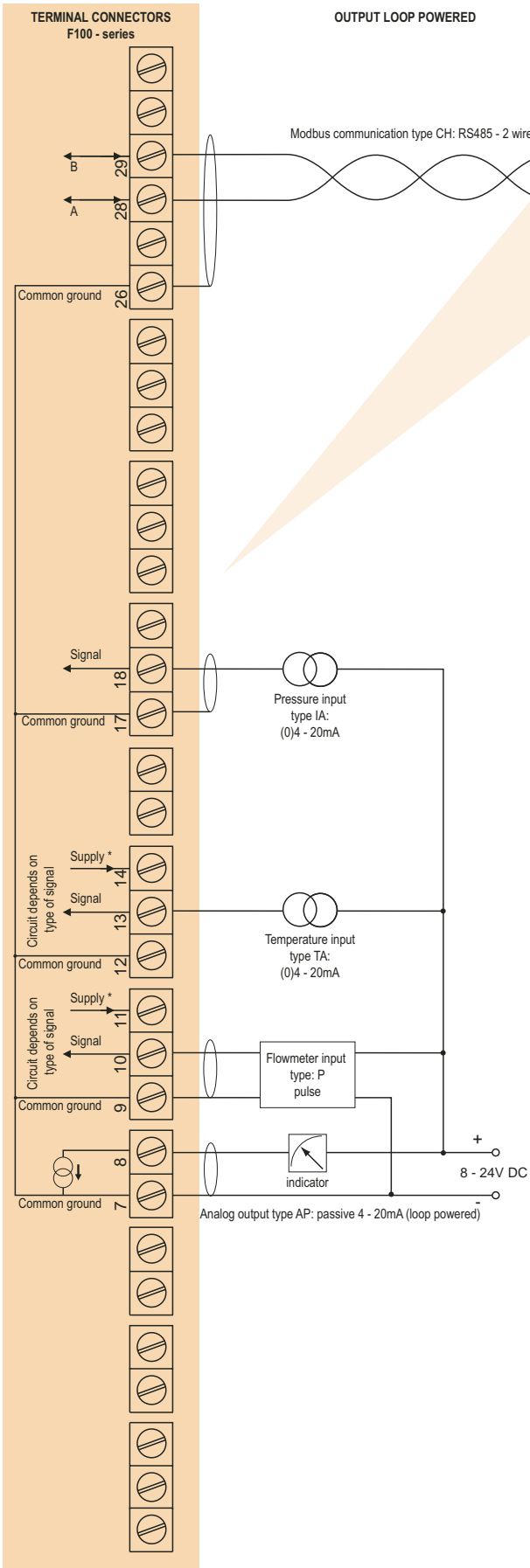

\*Supply voltage: 1.2 - 3.2V DC to sensor

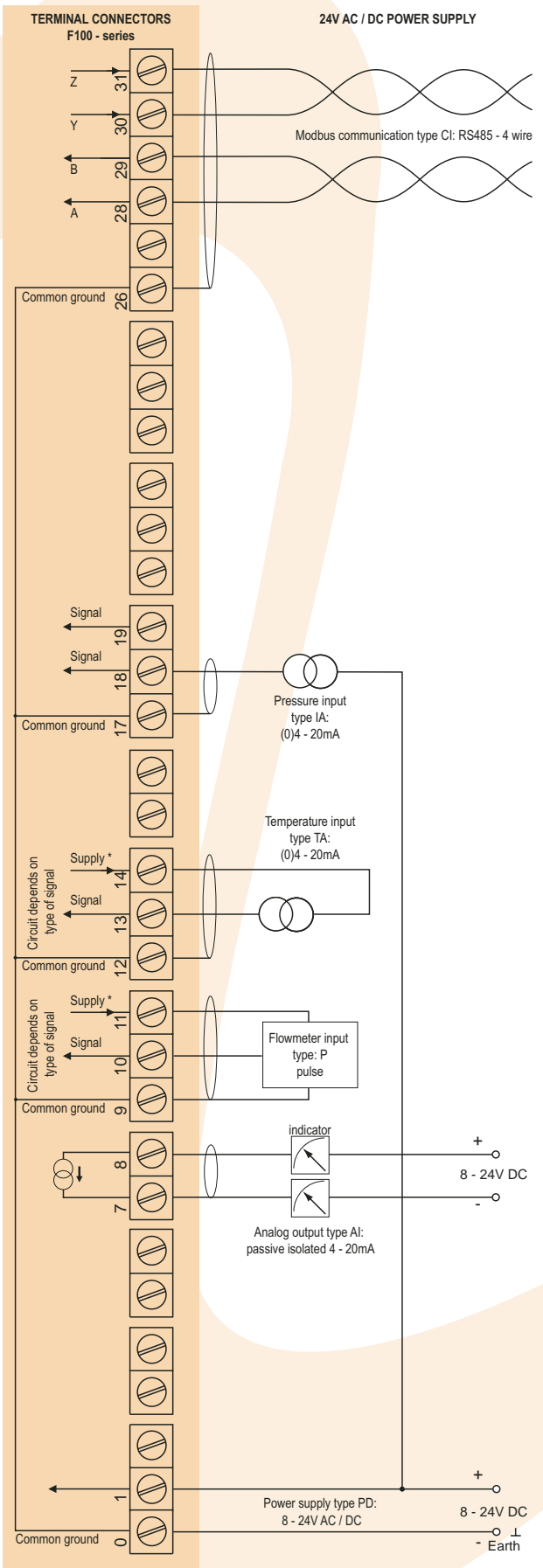

\*Supply voltage: 1.2 - 3.2 - 8.2 - 12 - 24V DC to sensor

Typical wiring diagram F126-A-AA-CB-EG-IA-PM-TP

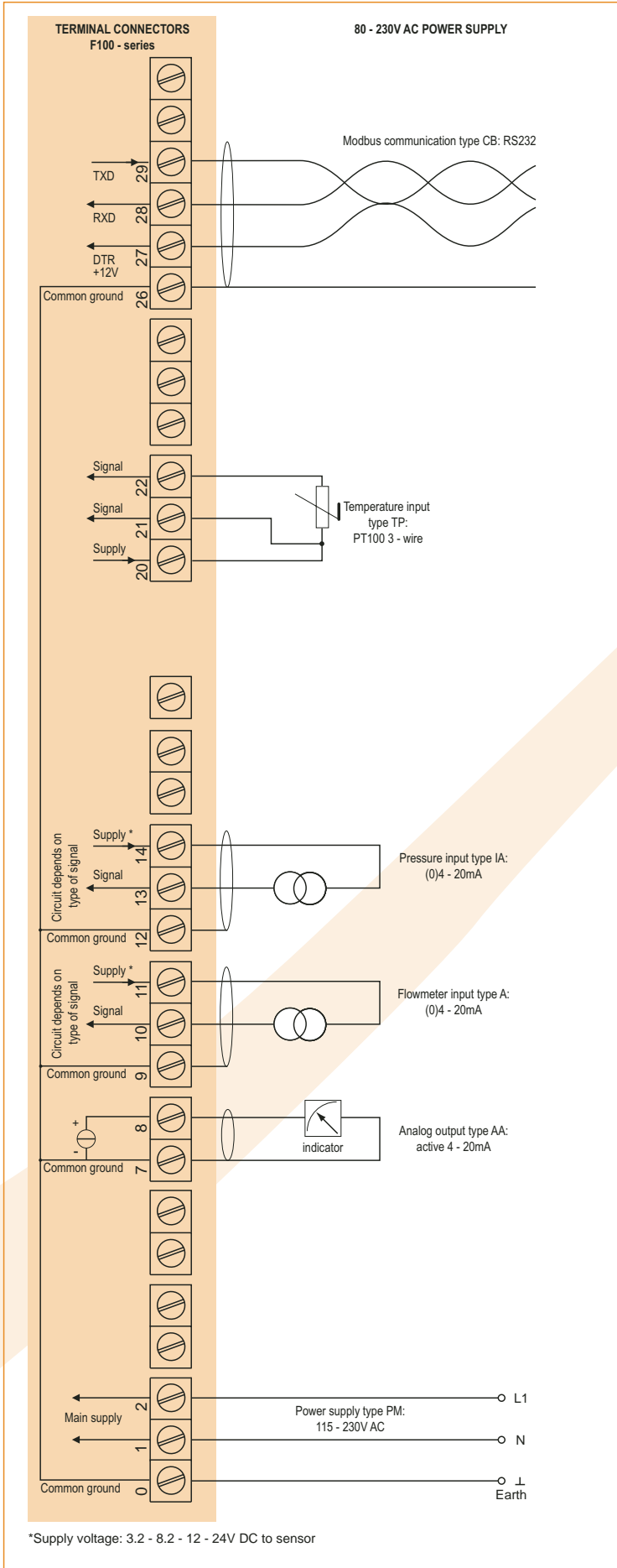

Typical wiring diagram F126-P-AI-CI-EG-IA-PM-TA

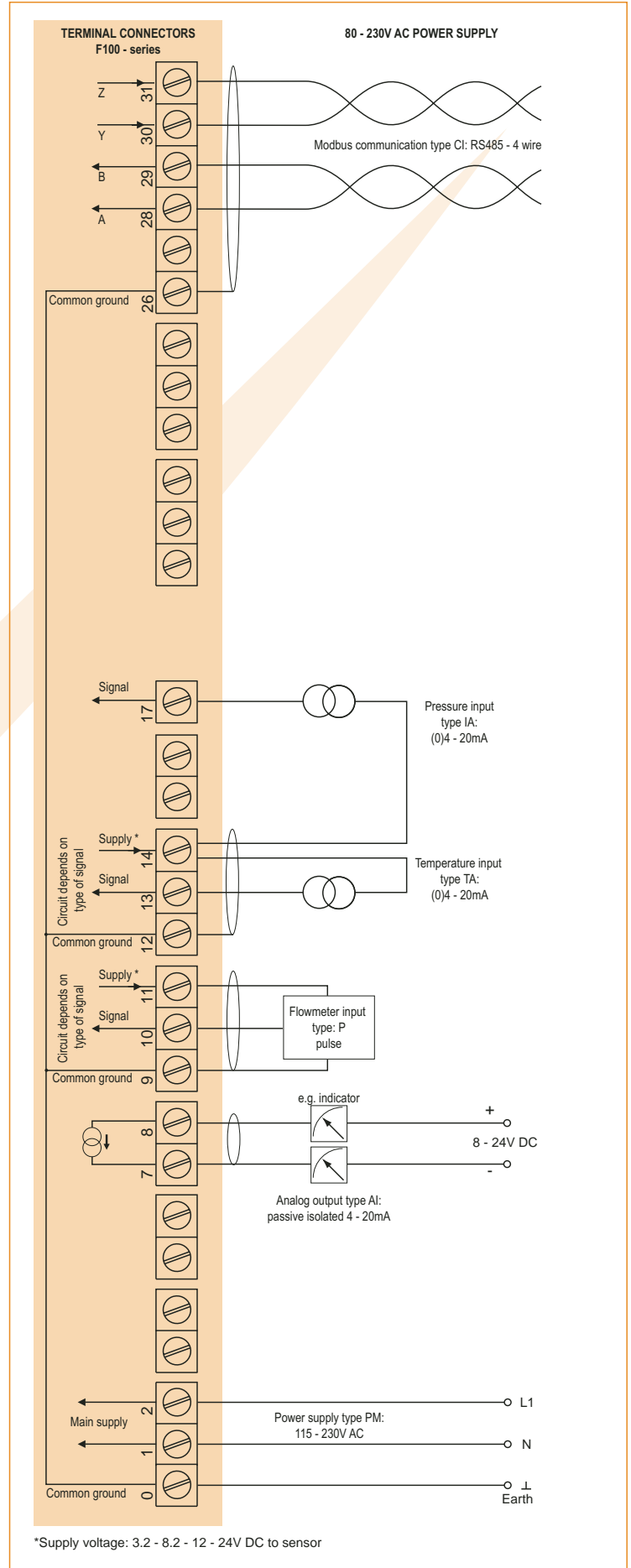

## Hazardous area applications

The F126-EG-XI has been ATEX approved by KEMA for use in intrinsically safe applications. It is approved according to  II 1GD EEx ia IIB/IIC T4 T100°C for gas and dust applications with an operational temperature range of -30°C to +70°C (-22°F to +158°F). It is allowed to connect up to five barriers in IIB applications or one barrier in IIC applications. Full functionality of the F126-EG remains available, including 4 - 20mA output according to the flowrate and Modbus communication (type CT).

Power supply type PD-XI offers a 8.2V sensor supply e.g. for one Namur sensor and two analog sensors. A flame proof enclosure with rating  II 2G EEx d IIB T5 is available as well. Please contact your supplier for further details.

## Certificate of conformity KEMA 03ATEX1074 X



### Configuration example IIB

**F126-P-(AP)-(CT)-EG-IA-PB-TP-XI - battery powered unit**

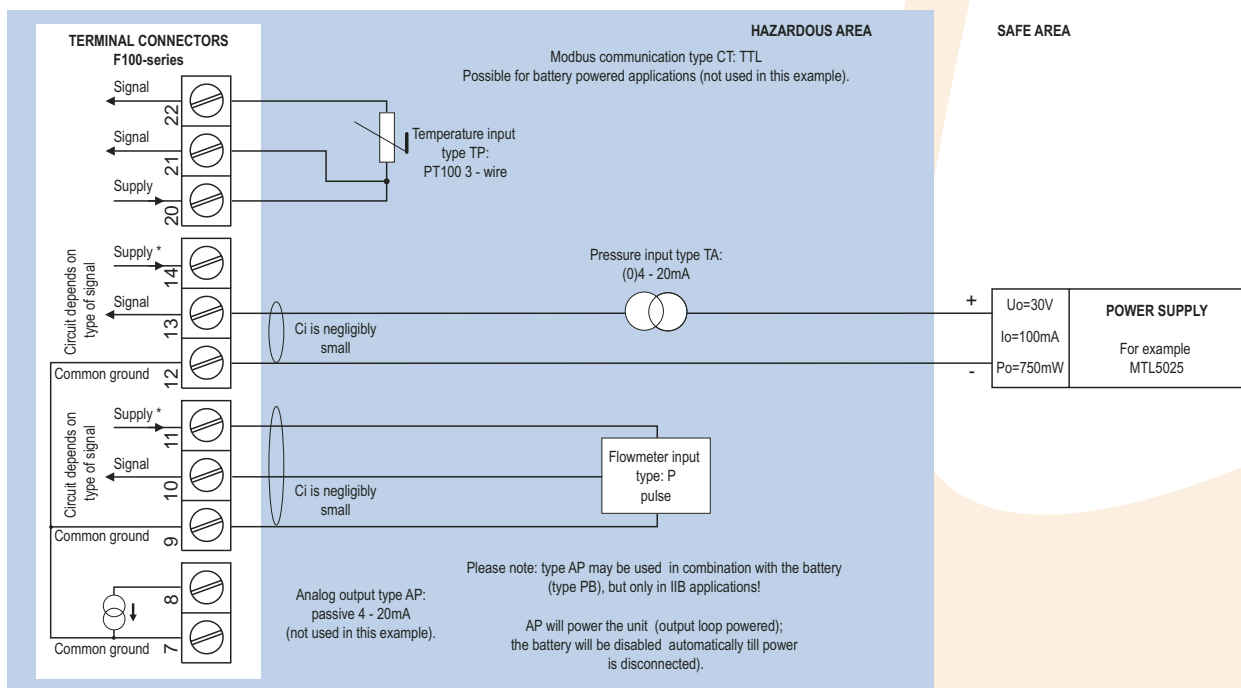

## Configuration example IIB - F126-P-AP-CT-EG-IA-TP-XI - output loop powered

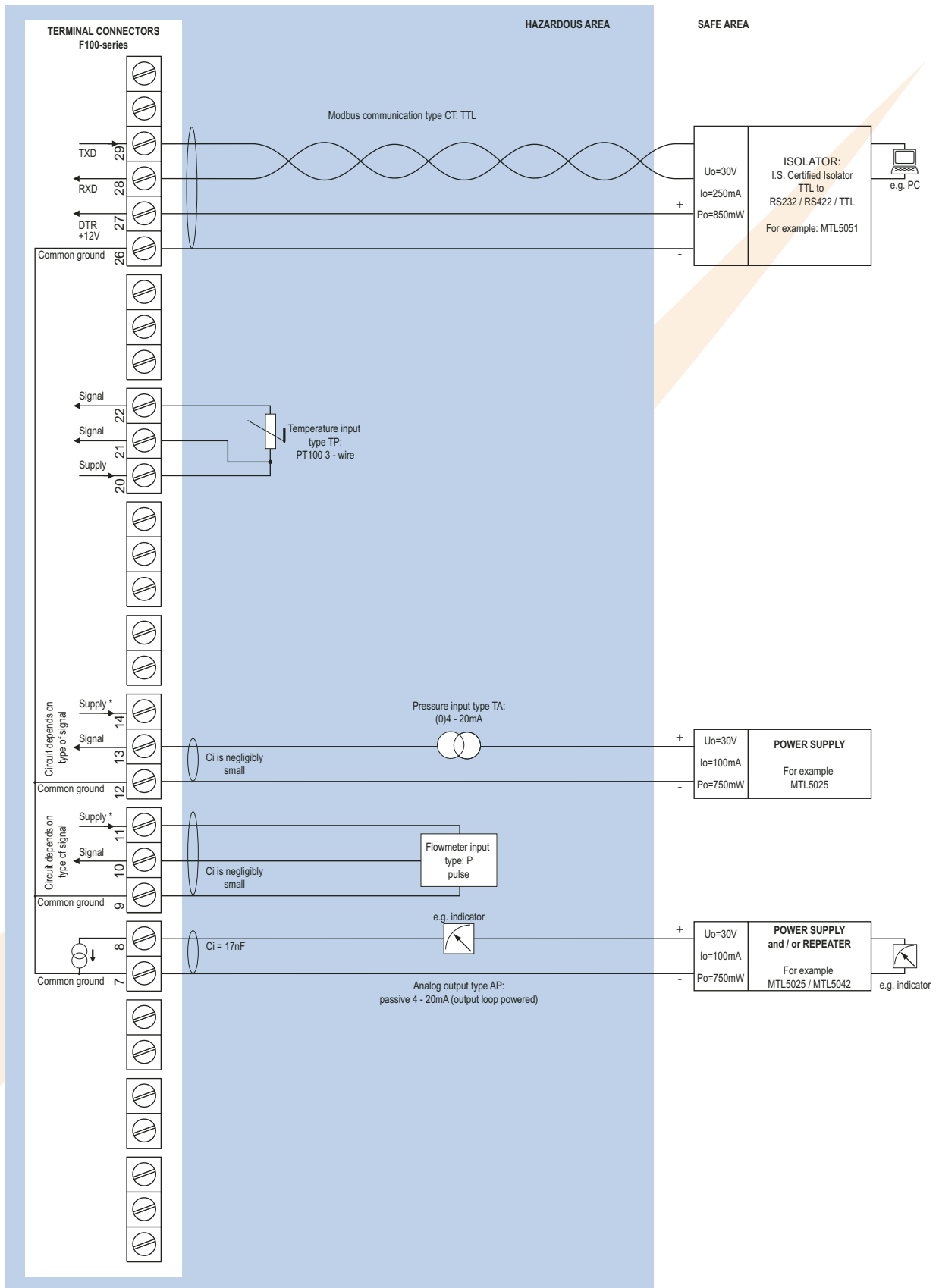

\* Note sensor supply voltage: 1.2V DC for coil sensors or 3.2V DC for other pulse sensors.

## Configuration example IIB and IIC - F126-A-AF-(CT)-EG-IA-PD-TA-XI - power supply 16 - 30V DC

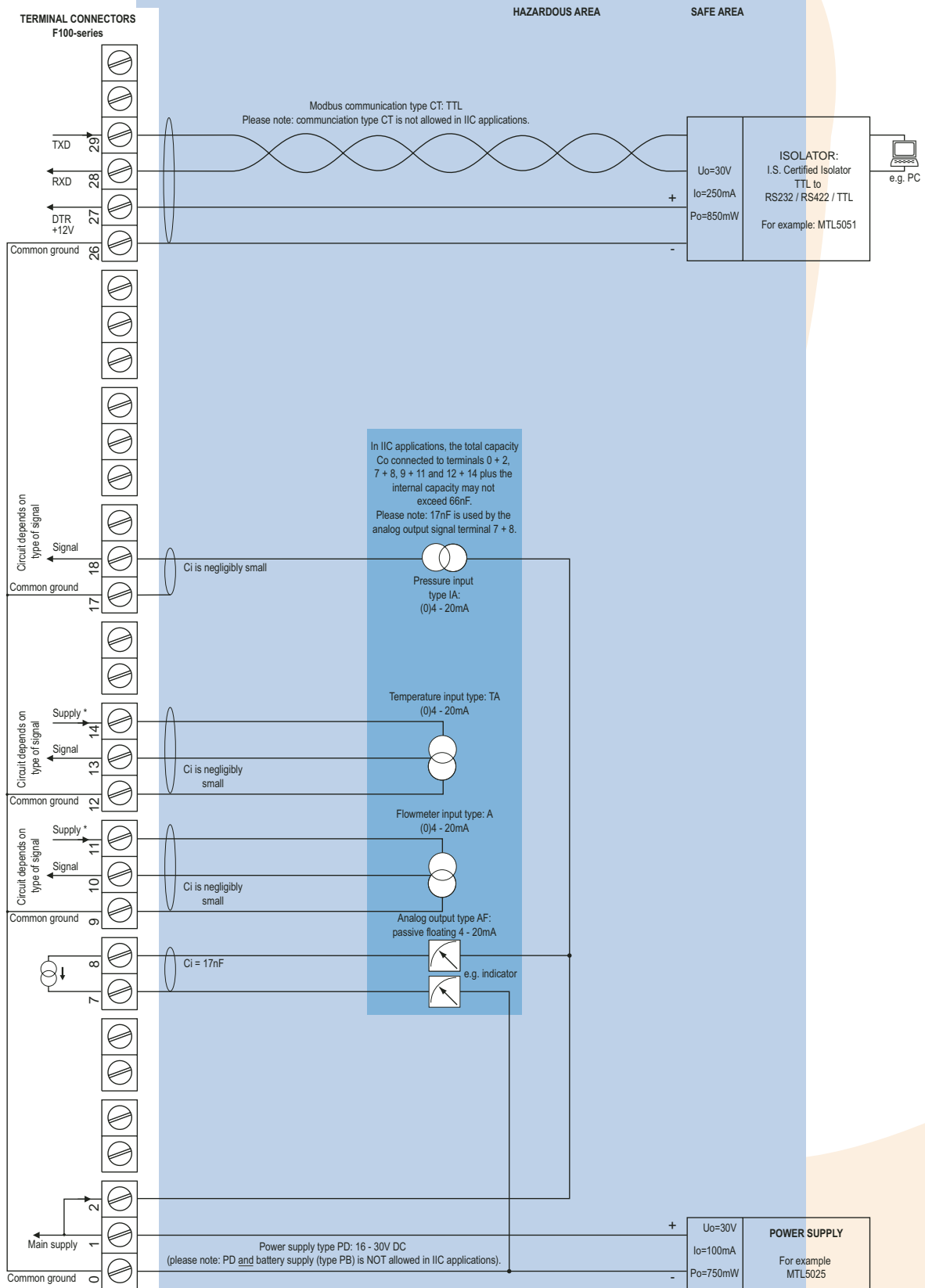

\* Note power supply type PD: the supply voltage to the sensor is as connected to terminal 1 (internally linked).

## Configuration example IIB - F126-A-AF-CT-EG-IA-(PB)-(PD)-(PL)-TA-XI

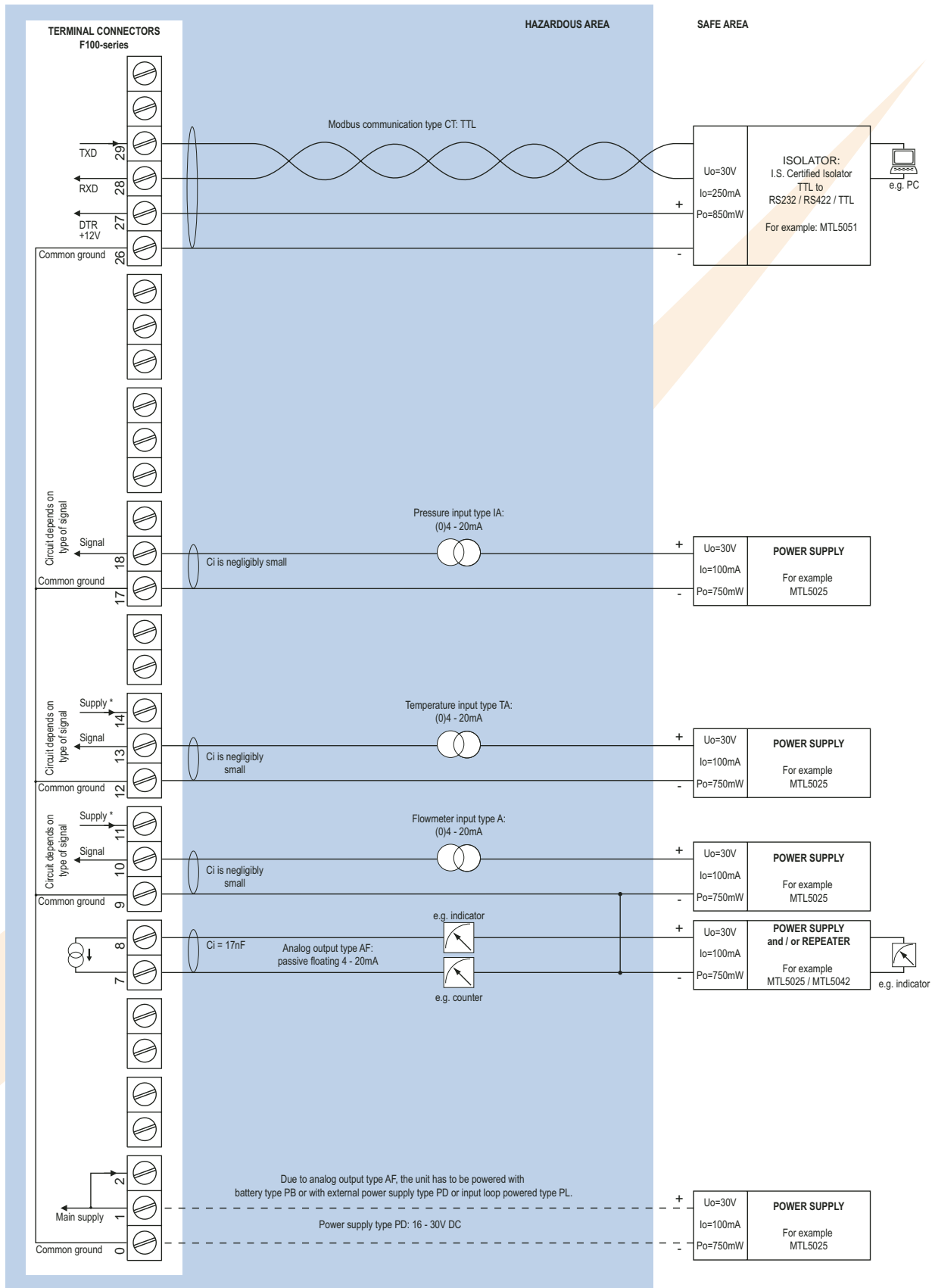

\* Note power supply type PD: the supply voltage to the sensor is as connected to terminal 1 (internally linked).

## Technical specification

### General

Display	
Type	High intensity reflective numeric and alphanumeric LCD, UV-resistant.
Dimensions	90 x 40mm (3.5" x 1.6").
Digits	Seven 17mm (0.67") and eleven 8mm (0.31") digits. Various symbols and measuring units.
Refresh rate	User definable: 8 times/sec. - 30 secs.
Option ZB	LED-backlight - available appr. Jan. 2005.

Casing	
Window	Polycarbonate window.
Sealing	EPDM and PE.
Control keys	Three industrial micro-switch keys. UV-resistant polyester keypad.
Type HA	Die-cast aluminum field mount enclosure IP67 / NEMA 4X with 2-component UV-resistant coating.
Dimensions	130 x 114 x 58mm (5.1" x 4.5" x 2.28") - W x H x D.
Cable Entry	2 x PG9 and 1 x M20 tapped hole in the centre.
Weight	950 gr.
Type HB	Die-cast aluminum panel mount enclosure IP65 / NEMA 4 with 2-component UV-resistant coating.
Dimensions	130 x 114 x 50mm (5.1" x 4.5" x 1.97") - W x H x D.
Panel cut-out	115 x 96mm (4.53" x 3.78") L x H.
Weight	525 gr.
Type HC	ABS panel mount enclosure IP65 / NEMA 4, UV-resistant and flame retardent.
Dimensions	130 x 114 x 48mm (5.1" x 4.5" x 1.89") - W x H x D.
Panel cut-out	115 x 96mm (4.53" x 3.78") L x H.
Weight	300 gr.
Type HD	ABS wall mount enclosure IP67 / NEMA 4X, UV-resistant and flame retardent.
Dimensions	130 x 114 x 71mm (5.1" x 4.5" x 2.8") - W x H x D.
Cable Entry	None, user defined.
Weight	400 gr.
Type HU	Die-cast aluminum field mount enclosure IP67 / NEMA 4X with 2-component UV-resistant coating.
Dimensions	5.1" x 4.5" x 2.28" - W x H x D.
Cable Entry	3 x 1/2" NPT tapped hole.
Weight	950 gr.



Operating temperature	
Operational	-30°C to +80°C (-22°F to +178°F).

Power requirements	
Type PB	Long life Lithium battery - life-time depends upon settings and configuration - up to 5 years.
Type PD	8 - 24V AC/DC ± 10%.
Type PD-XI	16 - 30V DC (Intrinsically Safe).
Type PL	Input loop powered from sensor signal 4 - 20mA (type "A") - requires types AI or AF.
Type PM	115 - 230V AC ± 10%.
Type PX	8 - 28V DC output loop powered unit with analog output signal type AP (or 8 - 24 V AC/DC if type AP will not be used).

Sensor excitation	
Type PB / PX	3.2V DC for pulse signals and 1.2V DC for coil pick-up.
Type PD	1.2 - 3.2 - 8.2 - 12 and 24V DC - max. 50mA@24V DC.
Type PD-XI	1.2 - 3.2 - 8.2V DC - max. 7mA@8.2V DC and mains power supply voltage (as connected to terminal 1).
Note	In case PD-XI and signal input type A or U, the sensor supply volage will be according to power supply voltage as connected to terminal 1.
Type PM	1.2 - 3.2 - 8.2 - 12 and 24V DC - max. 200mA@24V DC.

Terminal connections	
Type	Removable plug-in terminal strip. Wire max. 1.5mm <sup>2</sup> and 2.5mm <sup>2</sup> .

Data protection	
Type	EEPROM backup of all settings. Backup of running totals every minute. Data retention at least 10 years.
Pass-code	Configuration settings can be pass-code protected.

Hazardous area	
Intrinsically safe	ATEX approval ref:  II 1GD EEx ia IIB/IIC T4 T100°C.
Type XI	CSA/FM pending. Maximum ambient +70°C (158°F).
Explosion proof	ATEX approval ref:  II 2G EEx d IIB T5.
Type XD/XF	Dimensions of enclosure: 218 x 418 x 210mm (8.58" x 16.45" x 8.38") L x H x D.
Weight	16 Kg.

Environment	
Electromagnetic compatibility	Compliant ref: EN 61326 (1997), EN 61010-1 (1993).

Signal inputs	
Flowmeter	
Type P	Coil / sine wave (minimum 20mVpp or 80mVpp - sensitivity selectable), NPN/PNP, open collector, reed-switch, Namur, active pulse signals 8 - 12 and 24V DC.
Frequency	Minimum 0Hz - maximum 7kHz for total and flowrate. Maximum frequency depends on signal type and internal low-pass filter. E.g. reed switch with low-pass filter: max. frequency 120Hz.
K-Factor	0.000010 - 9,999,999 with variable decimal position.
Low-pass filter	Available for all pulse signals.
Option ZF	coil sensitivity 10mVpp.
Type A	(0)4 - 20mA. Analog input signal can be scaled to any desired range within 0 - 20mA.
Type U	0 - 10V DC. Analog input signal can be scaled to any desired range within 0 - 10V DC.
Accuracy	14 bit. Error < 0.05%. Low level cut-off programmable.
Span	0.000010 - 9,999,999 with variable decimal position.
Update time	Four times per second.
Voltage drop	Type A: 2.5V@20mA.
Load impedance	Type U: 3kΩ.
Relationship	Linear and square root calculation.
Note	For signal type A and U: external power to sensor is required; e.g. type PD.

## Temperature

Accuracy	14 bit. Error < 0.05%. Low level cut-off programmable.
Update time	Four times per second.
Type TA	(0)4 - 20mA. Analog input signal can be scaled to any desired range within 0 - 20mA.
Span	0.000010 - 9,999,999 with variable decimal position.
Offset	0.00 - 99,999.99 K.
Voltage drop	2.5V@20mA.
Type TP	2 or 3 wire PT100.
Range	-100°C to +200°C (-148°F to 392°F). Accuracy 0.1°C (0.18°F).
Option ZV	Range: -200°C to +800°C (-328°F to 1832°F). Accuracy 0.5°C (0.9°F).
Type TU	0 - 10V DC. Analog input signal can be scaled to any desired range within 0 - 10V DC.
Span	0.000010 - 9,999,999 with variable decimal position.
Offset	0.00 - 99,999.99 K.
Load impedance	3kΩ.
Note 1	For signal TA and TU: power supply to temperature sensor is required; e.g. PD.

## Pressure

Accuracy	14 bit. Error < 0.05%. Low level cut-off programmable.
Update time	Four times per second.
Type IA	(0)4 - 20mA. Analog input signal can be scaled to any desired range within 0 - 20mA.
Span	0.000010 - 9,999,999 with variable decimal position.
Offset	0.000 - 9,999.999.
Voltage drop	2.5V@20mA.
Type IU	0 - 10V DC. Analog input signal can be scaled to any desired range within 0 - 10V DC.
Span	0.000010 - 9,999,999 with variable decimal position.
Load impedance	3kΩ.
Note	For signal type IA and IU: external power to sensor required; e.g. PD.

## Signal outputs

### Analog output

Function	Transmitting compensated flowrate.
Accuracy	10 bit. Error < 0.05%. Analog output signal can be scaled to any desired range.
Update time	Ten times per second.
Type AA	Active 4 - 20mA output (requires PD or PM).
Type AB	Active 0 - 20mA output (requires PD or PM).
Type AF	Passive floating 4 - 20mA output for Intrinsically Safe applications (requires PB, PL or PD).
Type AI	Passive galvanically isolated 4 - 20mA output - also available for battery powered models (requires PB, PD, PL or PM).
Type AP	passive 4 - 20mA output - not isolated. Unit will be loop powered.
Type AU	Active 0 - 10V DC output (requires PD or PM).

### Communication option

Function	Reading display information, reading / writing all configuration settings.
Type CB	RS232
Type CH	RS485 2-wire
Type CI	RS485 4-wire
Type CT	TTL Intrinsically Safe.
Protocol	Modbus RTU.
Speed	1200 - 2400 - 4800 - 9600 baud.
Addressing	Maximum 255 addresses.

## Operational

### Operator functions

Displayed functions	<ul style="list-style-type: none"> <li>Compensated flowrate.</li> <li>Compensated total and accumulated total.</li> <li>Actual line temperature.</li> <li>Actual line pressure</li> <li>Total can be reset to zero by pressing the CLEAR-key twice.</li> </ul>
---------------------	--

### Total

Digits	7 digits.
Units	L, m3, GAL, USGAL, KG, lb, bbl, no unit.
Decimals	0 - 1 - 2 or 3.
Note	Total can be reset to zero.

### Accumulated total

Digits	11 digits.
Units / decimals	According to selection for total.
Note	Can not be reset to zero.

### Flowrate

Digits	7 digits.
Units	mL, L, m3, Gallons, KG, Ton, lb, bl, cf, RND, ft3, scf, Nm3, NI, ical - no units.
Decimals	0 - 1 - 2 or 3.
Time units	/sec - /min - /hr - /day.

### Line temperature

Digits	6 digits.
Units	°C, °F or K.
Decimals	1.

### Line pressure

Digits	6 digits.
Units	mbar, bar, PSI, no-unit.
Decimals	1.

### Flow equations

Type EG	Corrected gas volume.
Formula	$Q_{normal} = Q \times \left( \frac{P}{P_{normal}} \right) \times \left( \frac{T_{normal}}{T} \right) \times \left( \frac{C_{normal}}{C} \right)$
Normal pressure	Default: 1.013 bar.
Normal temperature	Default: 273.15K (0°C / 32°F)

## Display example - 90 x 40mm (3.5" x 1.6")

TOTAL	m <sup>3</sup>	
▲	139785.3	
RATE	RUN	1853 NM3/HR

## Ordering information

Example (standard configuration)

F126-P-AP-CX-EG-HC-IA-PX-TA-XX-ZX.

Explanation standard configuration:

**P:** flowmeter signal: pulse; **AP:** passive 4 - 20mA analog output; **CX:** no communication; **EG:** equations corrected gas volume; **HC:** ABS panel mount enclosure; **IA:** (0)4 - 20mA pressure input signal; **PX:** the unit is powered by the analog output loop, type AP: 8 - 28V DC (or AC); **TA:** (0)4 - 20mA temperature input signal; **XX:** Safe area; **ZX:** no options.

Ordering information:	F126	-	-A	-C	-EG	-H	-I	-P	-T	-X	-Z
<b>Flowmeter input signal</b>											
A	⊗										
P	⊗										
U	⊗										
<b>Analog output signal</b>											
AA											
AB											
AF	⊗										
AI											
AP	⊗										
AU											
<b>Communication</b>											
CB											
CH											
CI											
CT	⊗										
CX	⊗										
<b>Flow equations</b>											
EG	⊗										
<b>Enclosure</b>											
HA	⊗										
HB	⊗										
HC	⊗										
HD	⊗										
HU	⊗										
<b>Pressure input</b>											
IA	⊗										
IU	⊗										
<b>Power supply</b>											
PB	⊗										
PD	⊗										
PL	⊗										
PM											
PX	⊗										
<b>Temperature input</b>											
TA	⊗										
TP	⊗										
TU	⊗										
<b>Hazardous area</b>											
XI	⊗										
XD	⊗										
XF	⊗										
XX											
<b>Other options</b>											
ZB	⊗										
ZF	⊗										
ZV	⊗										
ZX	⊗										

The bold marked text contains the standard configuration.

⊗ Available Intrinsically Safe.

Specifications are subject to change without notice.

FLUIDWELL bv  
P.O. Box 6  
5460 AA - Veghel - The Netherlands  
Tel.: +31 (0)413 343786  
Fax.: +31 (0)413 363443  
sales@fluidwell.com  
Internet: www.fluidwell.com

