

PROCESS & TEMPERATURE UNIVERSAL INPUT DIGITAL METERS

NOVA PD560 Series



- Thermocouple, RTD, & Process Inputs
- Universal Power Supply 100-240 VAC
- Up to 3 Alarm Relays
- Retransmitting 4-20 mA Output
- Input Max/Min Display Reset with Digital Inputs
- RS-485 Serial Communications Option
- Modbus[®] RTU/ASCII Communications
- Free Monitoring & Data Logging Software
- IP55 & IP65 Fronts
- 1/8 & 1/4 DIN Sizes
- 3 Year Warranty

PRECISION DIGITAL CORPORATION

PRECISION
DIGITAL

www.predig.com

CUSTOM OPERATING DISPLAYS

The Nova Digital Meters have dual four-digit LEDs and can display commonly accessed parameters such as the maximum and minimum input values.

Operating Display Navigation

To access additional display information without the need to enter the setup menus, simply press the **SET/ENT** button.



Main Operating Display

- PV window displays process variable
- Press the **SET/ENT** button to move to the next display window



User Defined Display 1

- Display any setup parameter
- Parameters are fully functional, and can be set through this display
- Set by the user with parameter **US1**
- Press the **SET/ENT** button to move to the next display window

Example:

US1 Set to Display PV Max



User Defined Display 2

- Display any setup parameter
- Parameters are fully functional, and can be set through this display
- Set by the user with parameter **US2**
- Press the **SET/ENT** button to return to the main operating display

Example:

US2 Set to Display PV Min

EASY SETUP & PROGRAMMING

All programming of a Nova Digital Meter is done through the front panel. No switches or jumpers are required.

Front Panel Buttons

- Press the **SET/ENT** button to confirm an entered value. Hold the button for 3 seconds to enter or exit the setup groups. Press the **SET/ENT** button to access the next parameter when in a setup group.
- Press the **Up** button to increase numerical values or scroll through parameter options and group menus.
- Press the **Down** button to decrease numerical values or scroll through parameter options and group menus.
- Press the **LEFT** button to move to the next digit during numerical value programming.

Setup Group Menus

For easy parameter navigation, all parameters are grouped by category. To access the group menus, press and hold the **SET/ENT** button for 3 seconds. Navigate through the group menus using the **UP** and **DOWN** arrow buttons as shown. To enter a group menu to edit or view parameters, press the **SET/ENT** button.

Button	PV Display	Group Definition
ENT	PVd	Password
▲▼	G.CtL	Control Group
▲▼	G.In	Input Group
▲▼	G.ALñ	Alarm Group
▲▼	G.rEt	Retransmission Group
▲▼	G.Coñ*	Communications Group*

*This group menu appears only on models with the serial communication option.

Menu Password

To prevent unauthorized changes to key parameters, a user defined lockout password must be entered to access the group menus that are not commonly used during operation. Enter the password at the prompt when navigating the group menus by pressing the **SET/ENT** button. The default password is 0.

Easy to Use Menu Structure

Each parameter is located in an associated menu group.

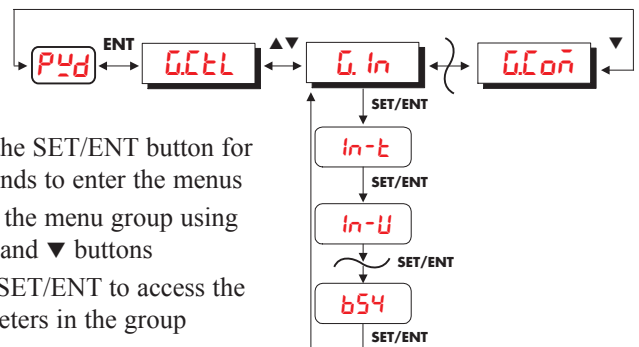

- Hold the **SET/ENT** button for 3 seconds to enter the menus
- Select the menu group using the **▲** and **▼** buttons
- Press **SET/ENT** to access the parameters in the group
- Set the value for the parameter, and use the **SET/ENT** button to select the next parameter
- Hold the **SET/ENT** button for 3 seconds to return to the operating display

For a complete list of setup parameters, their functions, and setting options, refer to the PD560 Series Instruction Manual.

PROCESS & TEMPERATURE INPUTS

Nova Digital Meters use a single universal input that accepts process and temperature inputs.

Thermocouple: J, K, T, E, R, B, S, L, N, U, W, Platinel II

RTD: Pt100 (0.00385), JPt100 (0.00392)

Process: -10 to 20 mV, 0 to 100 mV

0.4 to 2 V, 1 to 5 V, 0 to 10 V

4 to 20 mA input with a resistor shunt

GENERAL FEATURES

The PD560 Series of meters combines excellent standard features including a universal input, alarm relay, and a 4 to 20 mA retransmitting output with powerful options including an additional two alarm relays, digital inputs, and RS-485 serial communication including Modbus.

Alarm Relays

All PD560 Series Digital Meters have a standard 3 A Form C (SPDT) alarm relay. Up to two additional 1 A Form A (SPST) relays may be added. All relays can be programmed for a variety of alarm types.

- High/Low Alarms
- Set Point Deviation Alarms
- Fail-Safe and Standby Alarms
- Relay Delays and Reset Deadbands

4-20 mA Retransmitting Output

A 4-20 mA powered output is standard on all PD560 Series models. The output can be programmed to transmit over any input scale for any input type.

Transmitter Loop Power Supply

The 4-20 mA retransmitting output may be configured to provide a 14 to 18 VDC @ 20 mA transmitter power supply.

Input Bias Adjustment

Up to five bias points can be used to provide precise offset adjustments at specific input values. The controller will use the offset to create a smooth input value curve leading up to the bias points.

Display Max/Min Input Values

PD560 Digital Meters can record and display maximum and minimum input values. These values will be stored until reset by the user power to the meter is lost. Through the use of the user defined displays, these values can be accessible with the push of the SET/ENT button.

Digital Input Max/Min Reset

Two digital inputs can be added as an optional feature. Digital inputs are activated by closing contacts or low logic levels. The configuration of the two inputs can be used to hold or reset the maximum and minimum input values simultaneously or independently.

DISL	DI1	DI2	Operation
1	off	-	Reset MIN,MAX
	on	-	Start MIN,MAX
2	off	-	Reset MIN
	on	-	Start MIN
	-	off	Reset MAX
	-	on	Start MAX

NO switches (external excitation not required) or open collector transistor

Serial Communications & Adapters

Nova meters with the serial communications option can be used for data acquisition or with Modbus communication (RTU and ASCII). Nova meters transmit via RS-485. PDA7485 RS-232 to RS-485 isolated and non-isolated converters and PDA8485 USB to RS-485 isolated and non-isolated converters are available for use with the Nova Multi-Monitoring software or other PC applications.

NOVA PC SOFTWARE

Any Nova Controller with the serial communications option can be configured to interface with the Nova Multi-Monitoring PC software. Up to 30 meters can be monitored and operated, and each can use independent data logging.

- Easy to Set Up and Use
- Connect up to 30 Nova meters
- View PV and Alarm Status
- Log, View, and Save Data in Spreadsheet Files
- Free Download from www.predig.com

Specifications

System Requirements: Windows® 95\98\ME\2000\XP

Communications: An RS-232 to RS-485 or USB to RS-485 converter may be used for communication with a PC and Nova Multi-Monitoring Software.

Number of Units: Up to 30 Nova Controllers

Baud Rate: 9,600 to 19,200 bps

Data Logging: Graph and save data as .hdr format. Each controller saves graphs independently. Data exportable in spreadsheet format.

Logging Interval: 1 second to 24 hours

Simultaneous Monitoring

Simultaneously monitor up to 30 Nova Meters and view the PV and alarm status for all connected controllers. The main view screen also displays the basic model numbers of all connected units. Any series of Nova Controllers with the serial communications option may be monitored with this software.



Simultaneously View Up to 30 Nova Controllers

Real Time Indication and Graphing

A detailed operation screen for each controller indicates the model number of the meter, PV, alarm conditions, and maximum and minimum input values. A live updating graph shows PV information as it is logged.

Data Acquisition

PV data can be logged independently for each meter, and each can have a distinct file name, save location, and logging interval. This data can be graphed using the Data Viewer for quick and clear analysis. Logged data can be exported into spreadsheet format.

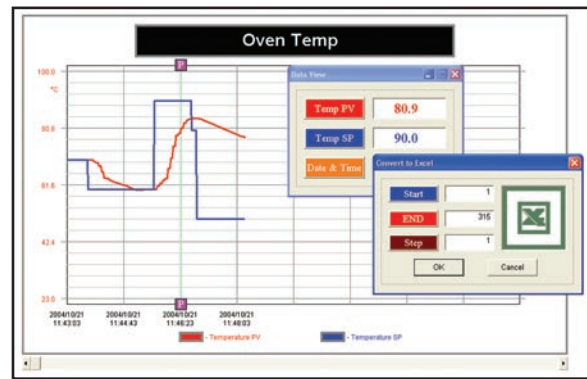

View Logged Data Graphs and Export Data

DIMENSIONS AND PANEL CUTOUTS

**Units: inches
(mm)**

PD562

1/8 DIN (H) (96 x 48)

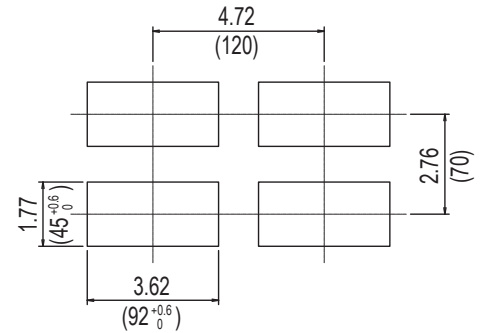
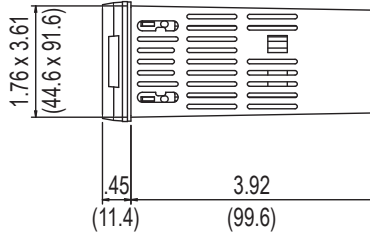
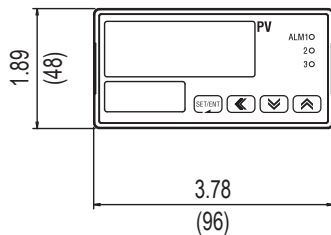

PD568

1/4 DIN (96 x 96)

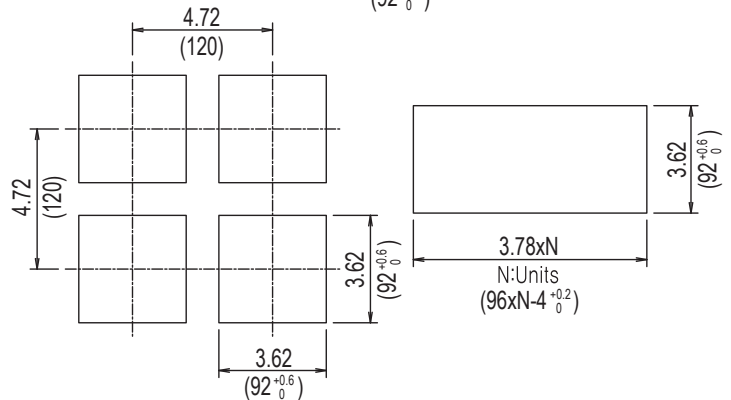
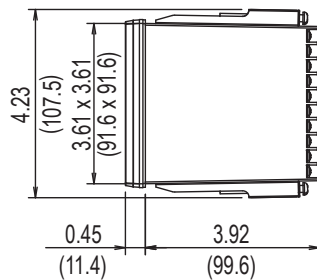
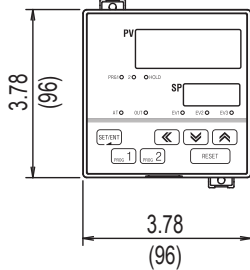

MODEL NUMBER GUIDE

The following guide describes the possible PD560 Series Nova Digital Process & Temperature Meter model numbers. Refer to the price list for the complete list of models and accessories.

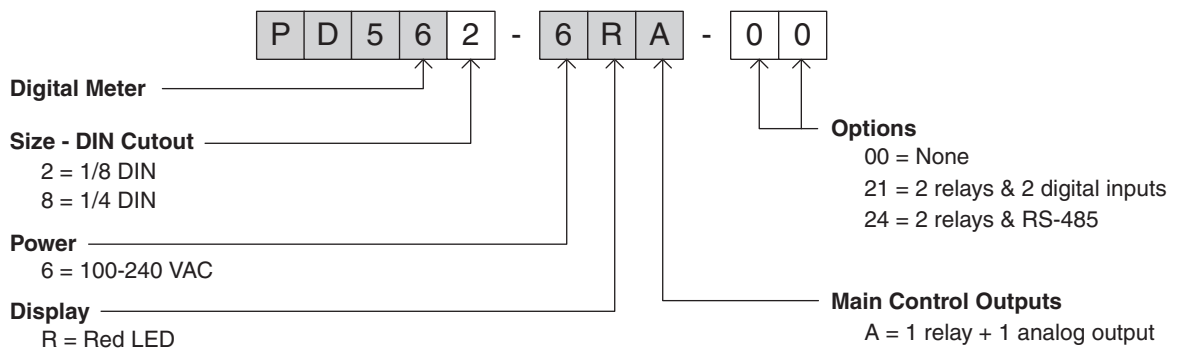

CONNECTIONS

PD562

: Options

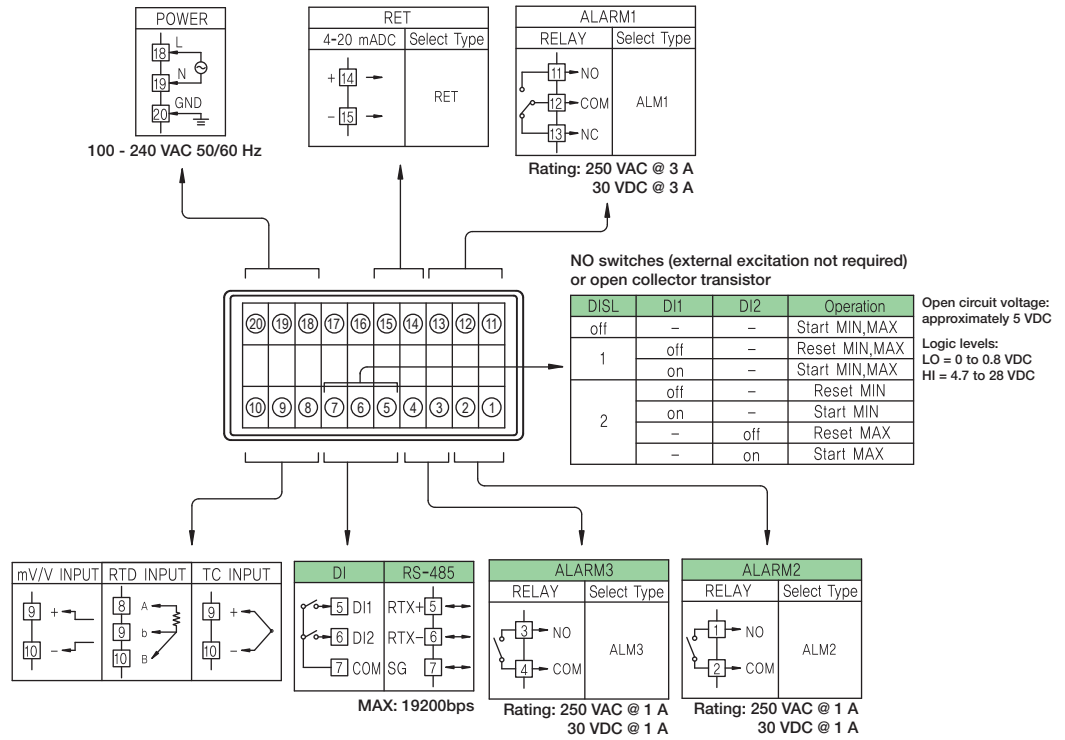

PD568

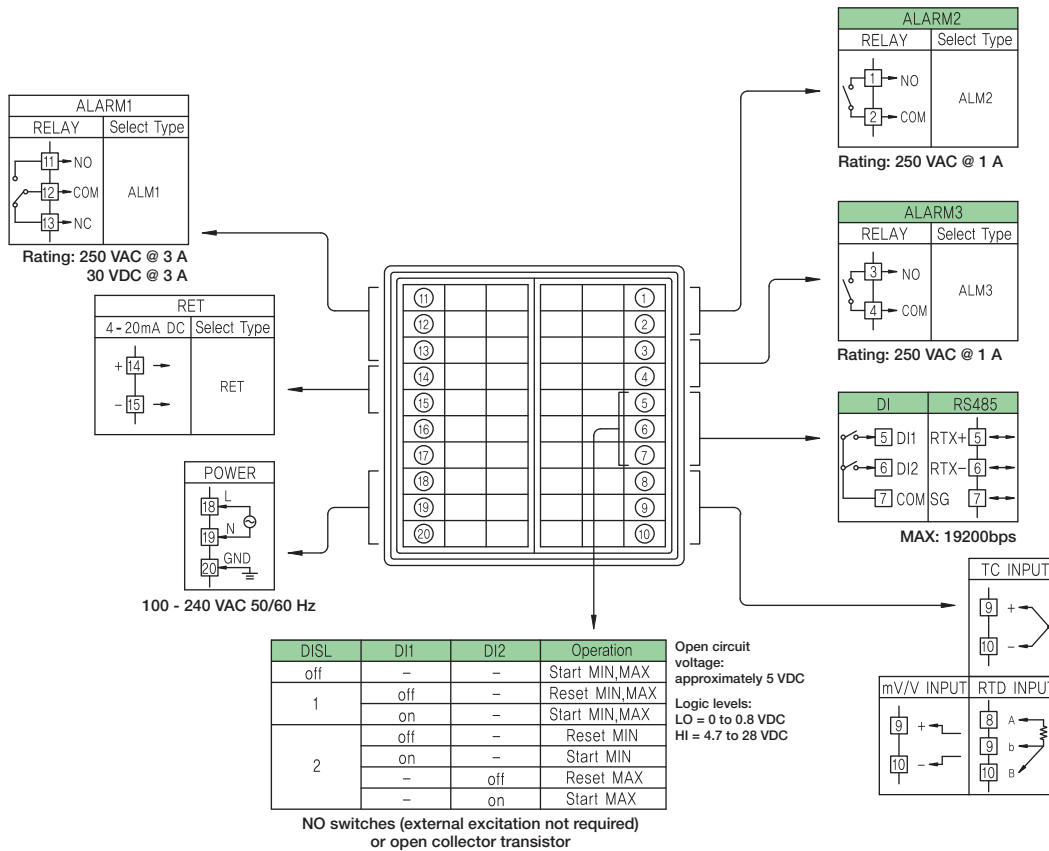

SPECIFICATIONS

Except where noted all specifications apply to operation at +25°C.

General

Display: Dual 4 digits, red LED, -1999 to 9999

DIN Sizes	PV Display Inch (mm)	SP Display Inch (mm)	Weight oz (g)
1/8 (H)	0.78 (19.8)	0.45 (11.5)	10.0 (285)
1/4	0.81 (20.5)	0.43 (11.0)	13.9 (394)

Front Panel: Panel gasket provided

1/8 DIN: IP65

1/4 DIN: IP55

Programming Methods: Four front panel buttons and Modbus

Noise Filter: Programmable 1 to 120 seconds, or off

Display Update Rate: 4/second

Max/Min Display: Stored until reset by user or meter is turned off.

Password: Restricts modification of programmed settings.

Non-Volatile Memory: Settings stored for a minimum of 10 years.

Power: 100-240 VAC, 50/60 Hz, 10 W

Required Fuse: UL Recognized, 1 A, 250 V, slow-blow

Isolation: 2300 V input/output-to-power line; 4 kV relay output-to-input/output/power line.

Operating Temperature: 10 to 50°C

Storage Temperature: -40 to 85°C

Relative Humidity: 20 to 90% non-condensing

Enclosure: 1/8 & 1/4 DIN available; impact-resistant plastic; color: black

Approvals: UL & C-UL Recognized, CE Compliant

UL File Number: E244207; Process Control Equipment

Warranty: 3 years parts & labor

Extended Warranty: 1 or 2 years, refer to Price List for details.

Temperature Inputs

Inputs: Factory calibrated, field selectable: J, K, T, E, B, R, S, L, U, N, W, and Platinel II thermocouples and 100 Ω platinum RTD (0.00385 or 0.00392 curve)

Cold Junction Reference: Automatic or off

Offset Adjustment: Four programmable input bias zones

Sensor Break: Up or down scale, user selectable; display reads 5.0Pn; alarm relays will follow the up or down scale selection.

Type	Range (°C)	Range (°F)	Accuracy*
Thermocouple	K1	-200 to 1370	-300 to 2500
	K2	-199.9 to 999.9	0 to 2300
	J	-199.9 to 999.9	-300 to 2300
	T	-199.9 to 400.0	-300 to 750
	E	-199.9 to 999.9	-300 to 1800
	B	0 to 1800	32 to 3300
	R	0 to 1700	32 to 3100
	S	0 to 1700	32 to 3100
	L	-199.9 to 900.0	-300 to 1600
	U	-199.9 to 400.0	-300 to 750
RTD	N	-200 to 1300	-300 to 2400
	W	0 to 2300	32 to 4200
	Platinel II	0 to 1390	32 to 2500
	PtA	-199.9 to 850.0	-300 to 1560
	PtB	-199.9 to 500.0	-199.9 to 999.9
	PtC	-19.99 to 99.99	-4.0 to 212.0
	JPtA	-199.9 to 500.0	-199.9 to 999.9
	JPtB	-150.0 to 150.0	-199.9 to 300.0

*Performance within recommended operating conditions (10 to 50 °C, 20 to 90% RH)

Process Inputs

Inputs: Field selectable: 0.4 to 2.0 V, 1 to 5 V, 0 to 10 V, -10 to 20 mV, 0 to 100 mV. 4-20 mA input requires 100 Ω resistor connected across input terminals (order P/N: PDX-RES1).

Accuracy: ±0.1% FS ±1 count

Decimal Point: Up to 3 decimals: 9.999, 99.99, 999.9, or 9999

Calibration: All inputs are calibrated at the factory

Scale Range: User programmable over entire range

Transmitter Supply: 14 to 18 VDC @ 20 mA; available instead of retransmitting analog output; selection is made through the front panel.

Alarm Relays

Ratings: 1 Form C (SPDT) standard; rated 3 A @ 30 VDC or 3 A @ 250 VAC resistive load. 1 or 2 Form A (SPST) optional; rated 1 A @ 30 VDC or 1 A @ 250 VAC resistive load.

High/Low Alarm: User may program any alarm for absolute high or low operation, forward or reverse (fail-safe) mode.

Alarm Deadband: 0-100% FS, user selectable

Alarm Delay: 0 to 99 minutes and 59 seconds

Reverse Operation (Fail-Safe): Programmable, independent for each alarm. Relay coils are energized in non-alarm condition. In case of power failure, relays will go to alarm state.

Forward Operation: Relay coils are energized in alarm condition. In case of power failure, relays will go to non-alarm state.

Auto Alarm Initialization: Normal and standby operation independent for each alarm. Normal alarms will reflect the state of the input to the meter at all times. Standby alarms will not trigger if the change to alarm state is a result of power up cycle, set point change, or alarm configuration change.

4-20 mA Retransmitting Output

Scaling Range: 4-20 mA output can be scaled for any display

Accuracy: ±0.1% FS

Power: Internally powered 4-20 mA output

Isolation: 500 V input-to-output

Output Loop Resistance: 600 Ω max

Digital Inputs

Configuration: Two contacts. Two operating modes.

Contacts: Normally open switches (external excitation note required) or open collector transistor

Open Circuit Voltage: Approximately 5 VDC

Logic Levels: LO = 0 to 0.8 VDC, HI = 4.7 to 28 VDC

Operation Modes: Mode 1: Store and reset max & min display values simultaneously. Mode 2: Store and reset max & min display values independently.

Serial Communications

Compatibility: EIA-485

Protocols: PC, Modbus (ASCII, RTU)

Address: 1 to 99 (Max 31 units connected)

Baud Rate: 600 to 19,200 bps

Transmit Time Delay: 0 to 100 ms

Data: 7 or 8 bit, automatic when using Modbus protocol

Stop Bit: 1 or 2

Parity: None, even, or odd

LDS560_B
06/05