

# NOVA

## PROCESS & TEMPERATURE CONTROLLERS

### DIGITAL CONTROLLER



### PROGRAMMABLE CONTROLLER



### DIGITAL METER



### LIMIT CONTROLLER





Jeffrey L. Peters  
President

Our new line of high accuracy digital process and temperature controllers expands on our 31-year history of providing customers with the best in digital display and control instrumentation. These controllers are available in a wide variety of enclosure sizes, accept all popular temperature sensors, and can be set up and operated with ease. So whether your application requires an auto-tune PID controller with two program storage capability or a simple limit controller, I think you will find what you are looking for here.

## Our Pledge to You!

- **Quality Policy**  
Through the combined efforts of all employees, we will pursue quality leadership through error free results in our products, processes, and services. Our goal is complete customer satisfaction and our commitment is to continuous improvement
- **No Minimum Order Requirement**
- **Drop Shipments at No Extra Charge**
- **Fast Warranty Replacements**
- **Fast, Courteous, and Knowledgeable Customer Service**



## Accuracy Reliability Convenience

*Your Complete Source for  
Controllers and Digital Meters*

- Instruction Manuals and Data Sheets
- Download the Free Nova Software
- Available 24 Hours a Day

[www.predig.com](http://www.predig.com)

## C

### ONTENTS

#### SERIES OVERVIEW

- 3 PD500 SERIES COMPARISON
- 4 PD540 SERIES DIGITAL CONTROLLER
- 6 PD550 SERIES PROGRAMMABLE CONTROLLER
- 8 PD560 SERIES DIGITAL METER
- 9 PD570 SERIES LIMIT CONTROLLER
- 10 SPECIAL FEATURES

#### PRODUCT DETAILS

- 13 PD540 SERIES DIGITAL CONTROLLER
- 18 PD550 SERIES PROGRAMMABLE CONTROLLER
- 22 PD560 SERIES DIGITAL METER
- 24 PD570 SERIES LIMIT CONTROLLER
- 26 DIMENSIONS AND PANEL CUTOUTS

DISCLAIMER: The information contained in this document is subject to change without notice. Precision Digital Corporation makes no representations or warranties with respect to the contents hereof, and specifically disclaims any implied warranties of merchantability or fitness for a particular purpose.

**PRECISION  
DIGITAL**

[www.predig.com](http://www.predig.com)

*Process & Temperature Controllers*

# NOVA

DIGITAL CONTROLLER  
 PROGRAMMABLE RAMP & SOAK CONTROLLER  
 DIGITAL METER  
 LIMIT CONTROLLER

A COMPLETE RANGE OF EXCEPTIONAL CONTROLLERS

## PD500 SERIES COMPARISON

	PD540 Series	PD550 Series	PD560 Series	PD570 Series
Controller Type	<b>Digital Controller</b>	<b>Ramp &amp; Soak Controller</b>	<b>Digital Meter</b>	<b>Limit Controller</b>
PID Control Outputs	Three Relays <sup>2</sup> Two Analog <sup>3</sup>	Three Relays <sup>2</sup> Two Analog <sup>3</sup>		
Limit Control Relay				One Latching Relay
Alarm Output Relays Only	(See Note 2)	(See Note 2)	Three Alarm Relays	One Alarm Relay
Retransmitting Outputs	(See Note 3)	(See Note 3)	One 4-20 mA	One 4-20 mA
Digital Inputs	Two	Two	Two	
Digital Outputs		Four		
Max/Min and Time Display			Max/Min Value	Max/Min Value, Over Limit Time
Set Point Programming		2 Programs, 15 Segments Each		Yes
Modbus Available	Yes	Yes	Yes	RS-485
Serial Communications	RS-485	RS-485	RS-485	

- Notes:
1. Maximum available options for each category shown above.
  2. PID controlled time proportional relay activation and alarm capabilities.
  3. Analog outputs capable of 4-20 mA or voltage pulse settings, and may be configured as retransmitting or PID control outputs.

PD540 SERIES  
DIGITAL CONTROLLER

# NOVA

## PD540



1/16 DIN

## PD544



3/16 DIN

Overall Size	Inches (for reference only)	1.89 x 1.89 x 3.94	2.83 x 2.83 x 3.94
	Millimeters (mm)	48 x 48 x 100	72 x 72 x 100
4 Digit LED Display Height		PV 0.45" (11.3 mm), SP 0.37" (9.5 mm)	PV 0.55" (14.0 mm), SP 0.47" (12.0 mm)
Display Update Rate		4/Second	
Indication Accuracy		±0.1% FS	
Control Loops and Modes		Single-Loop Control or Heating & Cooling	
Running Modes		Auto/Manual Output Control, Run/Stop (Manual or Timer)	
Number of Set Points		4 SP (3 PID Zones and 1 Deviation PID Zone)	
Sensor	PV Input	Universal Input	
	TC	J, K, T, E, R, B, S, L, N, U, W, Platinel II	
	RTD	Pt100 (0.00385), JPt100 (0.00392)	
	VDC	-10-20 mV, 0-100 mV, 0.4-2.0 V, 1-5 V, 0-10 V	
Control	Control Outputs	Universal Output (Max 3)	Universal Output (Max 5)
	Time-Proportional PID	Relay, SSR (V-Pulse)	
	Continuous PID	SCR (4-20 mA)	
Alarm	Capacity	1 Point Standard (Max 2)	1 Point Standard (Max 3)
	Type	20 Types (High/Low Temp Limit, Temp Deviation Range, etc)	
Retransmitting Output & Power Supply		4-20 mA (PV, SP, MV) or 14-18 VDC @ 20 mA Loop Power Supply	
SP Slope Rate		0-99 min 59 sec or 0-99 hour 59 min	
Digital Input	Number	2	
	Function	SP Select, Run/Stop	
Communication Protocols		PC Software, Modbus (ASCII, RTU), SYNC (Master, Slave)	
Power Supply		100-240 VAC, 50/60 Hz, 10 Watts Max	

### Model Number Guide

The ordering guide to the right describes how to order the best controller to fit your needs. Each of the following pages contain a specialized guide for the controller type and size described on that page.

#### Ordering Example:

A PD540 series 1/16 DIN Digital Temperature Controller with one 4-20 mA control output and two relays, as well as the serial communication option, would be ordered as a PD540-6RA-14.

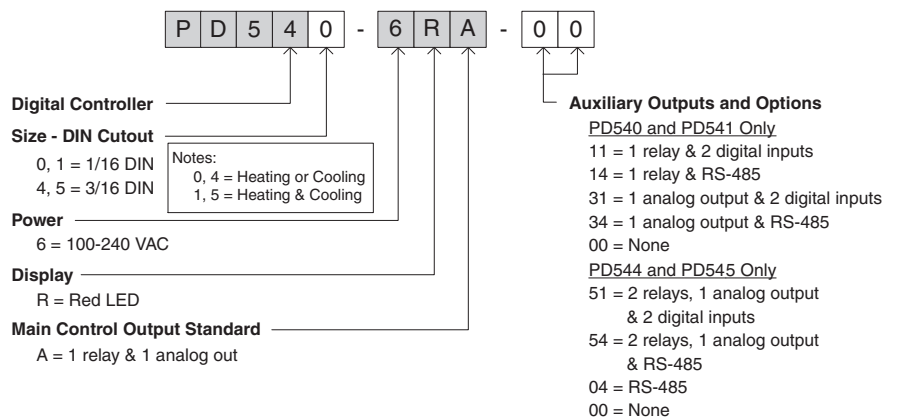

PD542



1/8 DIN(H)

PD546



1/8 DIN (V)

PD548



1/4 DIN

96 x 48 x 100

3.78 x 1.89 x 3.94

PV 0.78" (19.8 mm), SP 0.45" (11.5 mm)

48 x 96 x 100

1.89 x 3.78 x 3.94

PV 0.54" (13.6 mm), SP 0.41" (10.5 mm)

96 x 96 x 100

3.78 x 3.78 x 3.94

PV 0.81" (20.5 mm), SP 0.43" (11.0 mm)

4/Second

±0.1% FS

Single-Loop Control or Heating & Cooling

Auto/Manual Output Control, Run/Stop (Manual or Timer)

4 SP (3 PID Zones and 1 Deviation PID Zone)

Universal Input

J, K, T, E, R, B, S, L, N, U, W, Platine II

Pt100 (0.00385), JPt100 (0.00392)

-10-20 mV, 0-100 mV, 0.4-2.0 V, 1-5 V, 0-10 V

Universal Output (Max 5)

Relay, SSR (V-Pulse)

SCR (4-20 mA)

1 Point Standard (Max 3)

20 Types (High/Low Temp Limit, Temp Deviation Range, etc)

4-20 mA (PV, SP, MV) or 14-18 VDC @ 20 mA Loop Power Supply

0-99 min 59 sec or 0-99 hour 59 min

2

SP Select, Run/Stop

PC Software, Modbus (ASCII, RTU), SYNC (Master, Slave)

100-240 VAC, 50/60 Hz, 10 Watts Max

Model Number Guide

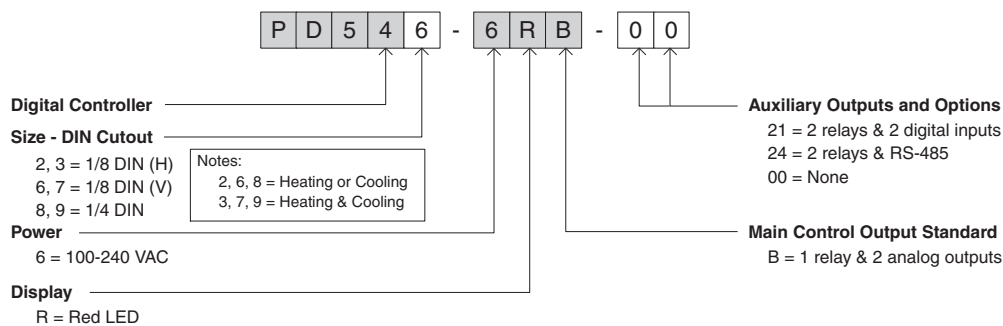

Ordering Example: A PD540 series 1/8 DIN (V) Digital Temperature Controller with two 4-20 mA outputs, three relays, and the serial communication option would be ordered as a PD546-6RB-24.

PD550 SERIES  
PROGRAMMABLE  
RAMP & SOAK CONTROLLER

# NOVA

## PD550



1/16 DIN

## PD554



3/16 DIN

Overall Size	Inches (for reference only)	1.89 x 1.89 x 3.94	2.83 x 2.83 x 3.94
	Millimeters (mm)	48 x 48 x 100	72 x 72 x 100
4 Digit LED Display Height		PV 0.45" (11.3 mm), SP 0.37" (9.5 mm)	PV 0.55" (14.0 mm), SP 0.47" (12.0 mm)
Display Update Rate		4/Second	
Indication Accuracy		±0.1% FS	
Control Loops and Modes		Single-Loop Control	
Running Modes		Prog/Reset (3 PID Zones and 1 Deviation PID Zone)	
Number of Programs		2 Program Patterns	
Number of Segments		15 Segments in Two Programs or One 30-Segment Program	
Sensor	PV Input	Universal Input	
	TC	J, K, T, E, R, B, S, L, N, U, W, Platinel II	
	RTD	Pt100 (0.00385), JPt100 (0.00392)	
	VDC	-10-20 mV, 0-100 mV, 0.4-2.0 V, 1-5 V, 0-10 V	
Control	Control Output	Universal Output (Max 3)	Universal Output (Max 5)
	Time-Proportional PID	Relay, SSR (V-Pulse)	
	Continuous PID	SCR (4-20 mA)	
Events (Max 7)	Capacity	1 Point Standard (Max 2)	1 Point Standard (Max 3)
	Alarm Types	20 Types (High/Low Temp Limit, Temp Deviation Range, etc)	
	Inner SP Signal	2 Points (PV, SP, TSP)	
	Program Time Signal	1 Point	
	Others	1 (Run, Pattern End, Up, Down, Soak)	
Retransmitting Output & Power Supply		4-20 mA (PV, SP, MV) or 14-18 VDC @ 20 mA Loop Power Supply	
Digital Input	Number	2	
	Function	4 Types (Run, Hold, Step, Reset)	
Communication Protocols		PC Software, Modbus (ASCII, RTU), SYNC (Master)	
Power Supply		100-240 VAC, 50/60 Hz, 10 Watts Max	

### Model Number Guide

#### Ordering Example:

A PD550 series 1/16 DIN Programmable Ramp & Soak Controller with one 4-20 mA control output, two relays, and digital inputs would be ordered as a PD550-6RA-11

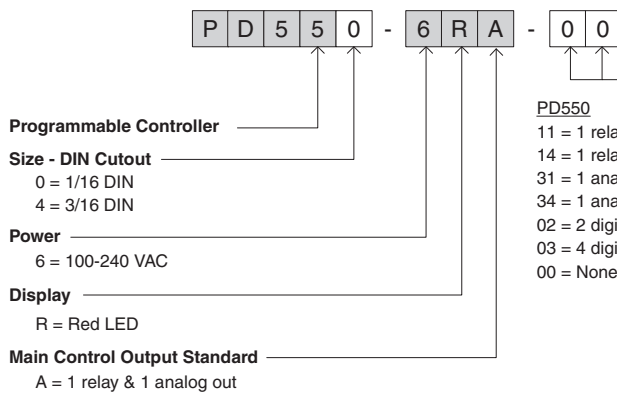

#### Auxiliary Outputs and Options

##### PD550

- 11 = 1 relay & 2 digital inputs
- 14 = 1 relay & RS-485
- 31 = 1 analog output & 2 digital inputs
- 34 = 1 analog output & RS-485
- 02 = 2 digital outputs
- 03 = 4 digital outputs
- 00 = None

##### PD554

- 51 = 2 relays, 1 analog output & 2 digital inputs
- 54 = 2 relays, 1 analog output & RS-485
- 52 = 2 relays, 1 analog output & 2 digital outputs
- 53 = 2 relays, 1 analog output & 4 digital outputs
- 02 = 2 digital outputs
- 03 = 4 digital outputs
- 04 = RS-485
- 00 = None

PD556



1/8 DIN (V)

PD558



1/4 DIN

1.89 x 3.78 x 3.94

48 x 96 x 100

PV 0.54" (13.6 mm), SP 0.41" (10.5 mm)

3.78 x 3.78 x 3.94

96 x 96 x 100

PV 0.81" (20.5 mm), SP 0.43" (11.0 mm)

4/Second

±0.1% FS

Single-Loop Control

Prog/Reset (3 PID Zones and 1 Deviation PID Zone)

2 Program Patterns

15 Segments in Two Programs or One 30-Segment Program

Universal Input

J, K, T, E, R, B, S, L, N, U, W, Platinel II

Pt100 (0.00385), JPt100 (0.00392)

-10-20 mV, 0-100 mV, 0.4-2.0 V, 1-5 V, 0-10 V

Universal Output (Max 5)

Relay, SSR (V-Pulse)

SCR (4-20 mA)

1 Point Standard (Max 3)

20 Types (High/Low Temp Limit, Temp Deviation Range, etc)

2 Points (PV, SP, TSP)

1 Point

1 Point (Run, Pattern End, Up, Down, Soak)

4-20 mA (PV, SP, MV) or 14-18 VDC @ 20 mA Loop Power Supply

2

4 Types (Run, Hold, Step, Reset)

PC Software, Modbus (ASCII, RTU), SYNC (Master)

100-240 VAC, 50/60 Hz, 10 Watts Max

Model Number Guide

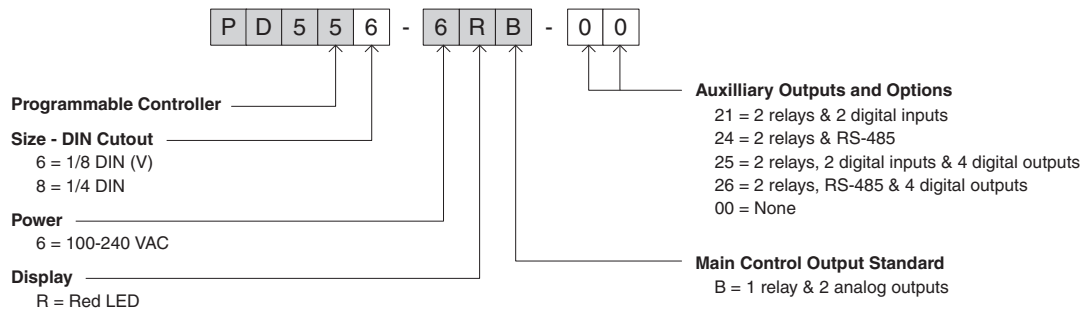

Ordering Example: A PD550 series 1/8 DIN (V) Programmable Ramp & Soak Controller with two 4-20 mA outputs, three relays, and the serial communication option would be ordered as a PD556-6RB-24.

PD560 SERIES  
DIGITAL METER

# NOVA

## PD562



## PD568



Overall Size	Millimeters (mm)	3.78 x 1.89 x 3.94	3.78 x 3.78 x 3.94
	Inches (for reference only)	96 x 48 x 100	96 x 96 x 100
4 Digit LED Display Height		PV 0.78" (19.8 mm), SP 0.45" (11.5 mm)	PV 0.81" (20.5 mm), SP 0.43" (11.0 mm)
Display Update Rate		4/Second	
Indication Accuracy		±0.1% FS	
Sensor	PV Input	Universal Input	
	TC	J, K, T, E, R, B, S, L, N, U, W, Platinel II	
	RTD	Pt100 (0.00385), JPt100 (0.00392)	
	VDC	-10-20 mV, 0-100 mV, 0.4-2.0 V, 1-5 V, 0-10 V	
Alarm	Capacity	1 Point Standard (Max 3)	
	Type	8 Types (High/Low Temp Limit, Temp Deviation Range, etc)	
Retransmitting Output & Power Supply		4-20 mA (PV) or 14-18 VDC @ 20 mA Loop Power Supply	
Digital Input	Number	2	
	Function	2 Types (PV Max/Min, Reset Max/Min)	
Communication Protocols		PC Software, Modbus (ASCII, RTU)	
Power Supply		100-240 VAC, 50/60 Hz, 10 Watts Max	

### Model Number Guide

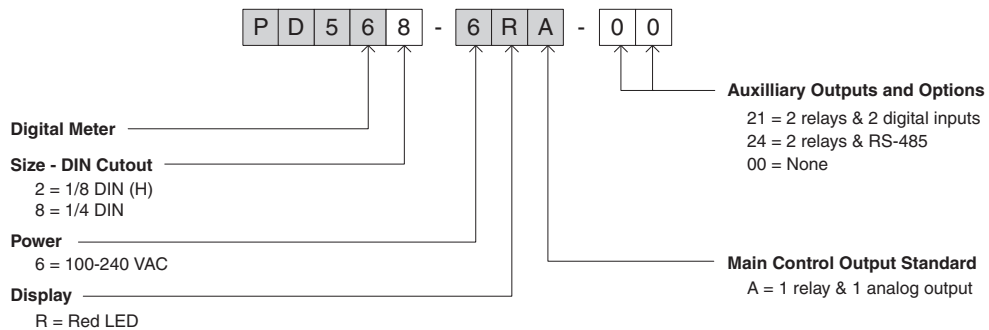

Ordering Example: A PD560 series 1/4 DIN Digital Meter with one 4-20 mA retransmitting output, three relays, and digital inputs would be ordered as a PD568-6RA-21.

PD570

PD578

PD570 SERIES  
LIMIT CONTROLLER

NOVA



1/16 DIN



1/4 DIN

Overall Size	Inches (for reference only)	1.89 x 1.89 x 3.94	3.78 x 3.78 x 3.94
	Millimeters (mm)	48 x 48 x 100	96 x 96 x 100
4 Digit LED Display Height		PV 0.45" (11.3 mm), SP 0.37" (9.5 mm)	PV 0.81" (20.5 mm), SP 0.43" (11.0 mm)
Display Update Rate		4/Second	
Indication Accuracy		±0.1% FS	
Control Loops and Modes		Single-Loop Control Heating or Cooling	
Sensor	PV Input	Universal Input	
	TC	J, K, T, E, R, B, S, L, N, U, W, Platinel II	
	RTD	Pt100 (0.00385), JPt100 (0.00392)	
	VDC	-10-20 mV, 0-100 mV, 0.4-2.0 V, 1-5 V, 0-10 V	
Alarm	Capacity	1 Point Standard	
	Type	20 Types (High/Low Temp Limit, Temp Deviation Range, etc)	
Retransmitting Output & Power Supply		4-20 mA (PV, SP) or 14-18 VDC @ 20 mA Loop Power Supply	
Communication Protocols		PC Software, Modbus (ASCII, RTU)	
Power Supply		100-240 VAC, 50/60 Hz, 10 Watts Max	

Model Number Guide

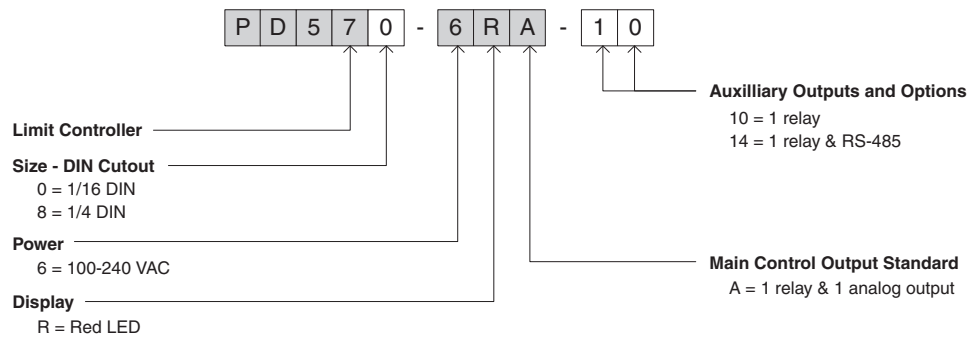

Ordering Example: A PD570 series 1/4 DIN Limit Controller with one 4-20 mA retransmitting output, one latching relay, and one alarm relay would be ordered as a PD578-6RA-10.

# Unique Features of the Nova Series Controllers

## Multiple Simultaneous Outputs (Max 5)

- Multiple and simultaneous output types are available, including relays, SSR (V-Pulse), and SCR (4-20 mA).
- Maximum of five heaters can be controlled with just one controller.

### Available Outputs

		Control Output			SUB (Aux) Relay Output		Digital Output			
		1	2	3	1	2	D01 - D04			
Output Settings	PD550 Series Programmable Controller	PD540 Series Digital Controller	Control PID Output (Heat)	✓	✓	✓	✓	✓		
			Control PID Output (Cool)	✓	✓	✓	✓	✓		
			Alarm 1	✓			✓	✓		✓
			Alarm 2	✓			✓	✓		✓
			Alarm 3	✓			✓	✓		✓
			Running	✓			✓	✓		✓
			Retransmitting Output		✓	✓				
			Inner SP Signal Output 1	✓			✓	✓		✓
			Inner SP Signal Output 2	✓			✓	✓		✓
			Time Signal Output	✓			✓	✓		✓
			Program End Alert	✓			✓	✓		✓
			SP Status (Up, Down, Soak)							✓

## Easy Parameter Setup With Dual LED Displays

- Dual LED displays show both the parameter being set, and its setting options.

## Built-in Run and Stop Output Functions (Manual and Timer)

- Manual output Run/Stop control through easily accessible menus.
- Timer functions can be set to activate the outputs after a set time from power-up, and to turn the outputs off after another set time period.

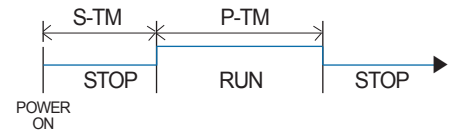

## Programmable Temperature Bias (4 Zones)

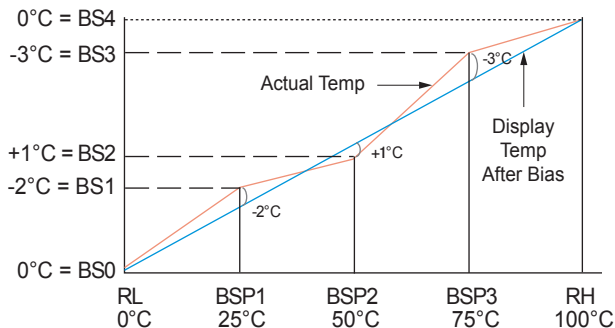

The actual temperature is shown within the range of 0°C (RL) and 100°C (RH). Bias points have been used to adjust the displayed temperature as shown in the graph.

To establish this bias, the settings are shown below.

Temperature Settings to Establish Where the Bias Occurs				
RL	BSP1	BSP2	BSP3	RH
0°C	25°C	50°C	75°C	100°C
Bias Offset for Each Point				
BS0	BS1	BS2	BS3	BS4
0°C	-2°C	+1°C	-3°C	0°C

The graph to the left illustrates how these settings affect the displayed temperature.

### Auto-Tuning PID with Automatic Gain Control

- All PID control parameters set automatically with Auto-tuning.
- Adjustable Gain value allows for simple user adjustments.
- To reach the set point faster, lower the Gain value.
- To achieve greater accuracy with less overshoot, increase the Gain value.
- Fuzzy Logic used to achieve high accuracy results.

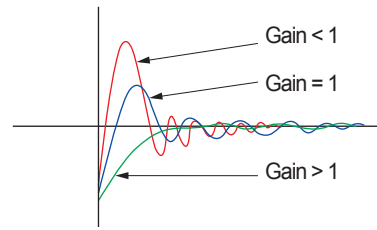

### Limit Controller for Checking Temperatures

- Latching relay used for limit control.
- Front panel button used to reset the latching relay.
- Alarm relay for added monitoring capabilities.
- Can monitor heating or cooling processes.
- Maximum and minimum temperatures recorded for display at the push of a button.
- Time since system shutdown stored and displayed until system reset.

### Universal Input Selection

Input		Temperature Range (°C)	Temperature Range (°F)	Accuracy*
Thermocouple	K1	-200 to 1370	-300 to 2500	
	K2	-199.9 to 999.9	0 to 2300	≥ 0°C : ±0.1% ±1 count
	J	-199.9 to 999.9	-300 to 2300	< 0°C : ±0.2% ±1 count
	T	-199.9 to 400.0	-300 to 750	
	B	0 to 1800	32 to 3300	≥ 400°C : ±0.15% ±1 count < 400°C : ±5% ±1 count
	R	0 to 1700	32 to 3100	
	S	0 to 1700	32 to 3100	±0.15% ±1 count
	E	-199.9 to 999.9	-300 to 1800	≥ 0°C : ±0.1% ±1 count
	L	-199.9 to 900.0	-300 to 1600	< 0°C : ±0.2% ±1 count
	U	-199.9 to 400.0	-300 to 750	
	N	-200 to 1300	-300 to 2400	≥ 0°C : ±0.1% ±1 count < 0°C : ±0.25% ±1 count
W	0 to 2300	32 to 4200	±0.2% ±1 count	
Platinel II	0 to 1390	32 to 2500	±0.1% ±1 count	
RTD	PtA	-199.9 to 850.0	-300 to 1560	±0.1% ±1 count**
	PtB	-199.9 to 500.0	-199.9 to 999.9	
	PtC	-19.99 to 99.99	-4.0 to 212.0	±0.2% ±1 count
	JPtA	-199.9 to 500.0	-199.9 to 999.9	±0.1% ±1 count**
	JPtB	-150.0 to 150.0	-199.9 to 300.0	
DC Voltage	0.4 to 2.0 V	0.400 to 2.000		All Voltage Ranges ±0.1% ±1 count Display range can be scaled between -1999 and 9999.
	1 to 5 V	1.000 to 5.000		
	0 to 10 V	0.00 to 10.00		4 to 20 mA Range To accept a 4 to 20 mA signal, select 0.4 to 2.0 VDC input and connect a 100 Ω resistor across the input terminals.
	-10 to 20 mV	-10.00 to 20.00		
	0 to 100 mV	0.0 to 100.0		

\*Performance at optimal operating conditions (23 ± 2°C, 55 ± 10% RH, 50/60 Hz AC powered)

\*\*For a range scale of 0 to 100°C: ±0.3°C ±1 count, and for a range scale of -100 to 100°C: ±0.5°C ±1 count

## Control Modes

Type of Control Mode	Description
Continuous PID	Output Current: 4-20 mA (600 $\Omega$ maximum) Output Accuracy: $\pm 0.1\%$ of FS
Time-Proportional PID Voltage Pulse Output	Voltage 'On': 15 VDC (600 $\Omega$ minimum, current limited to 30 mA) Voltage 'Off': < 0.1 VDC Cycle Time: 1 to 300 seconds, user selectable
Time-Proportional PID Relay Output	Contact Rating: 250 VAC @ 3 A, 30 VDC @ 3 A (resistive load) Cycle Time: 1 to 300 seconds, user selectable

## 20 Alarm Types



**S** indicates standby operation

**F** for forward operation:  
Relay energized in alarm condition.  
**r** for reverse operation (fail-safe):  
Relay energized during normal  
operating conditions.

Decimal point always displayed

**H** indicates high alarm  
**L** indicates low alarm  
**o** outside range of deviation band  
**i** inside range of deviation band

**A** indicates an absolute value alarm  
**d** indicates deviation alarm

No.	Type	Display
1	Absolute Value High Limit Alarm (Forward)	<b>AHF</b>
2	Absolute Value Low Limit Alarm (Forward)	<b>ALF</b>
3	High Limit Deviation Alarm (Forward)	<b>dHF</b>
4	Low Limit Deviation Alarm (Forward)	<b>dLF</b>
5	High Limit Deviation Alarm (Reverse)	<b>dHr</b>
6	Low Limit Deviation Alarm (Reverse)	<b>dLr</b>
7	High and Low Limit Deviation Alarm (Forward)	<b>doF</b>
8	High and Low Limit Range Deviation Alarm (Forward)	<b>d iF</b>
9	Absolute Value High Limit Alarm (Reverse)	<b>AHr</b>
10	Absolute Value Low Limit Alarm (Reverse)	<b>ALr</b>
11	Absolute Value High Limit Alarm with Standby (Forward)	<b>AHFS</b>
12	Absolute Value Low Limit Alarm with Standby (Forward)	<b>ALFS</b>
13	High Limit Deviation Alarm with Standby (Forward)	<b>dHFS</b>
14	Low Limit Deviation Alarm with Standby (Forward)	<b>dLFS</b>
15	Low Limit Deviation Alarm with Standby (Reverse)	<b>dHrS</b>
16	High Limit Deviation Alarm with Standby (Reverse)	<b>dLrS</b>
17	High and Low Limit Deviation Alarm with Standby (Forward)	<b>doFS</b>
18	High and Low Limit Range Deviation Alarm with Standby (Forward)	<b>d iFS</b>
19	Absolute Value High Limit Alarm with Standby (Reverse)	<b>AHrS</b>
20	Absolute Value Low Limit Alarm with Standby (Reverse)	<b>ALrS</b>



Digital Controller PD540

- Dual LED displays show the set point and process variable
- Gain function protects against overshoot
- 1 alarm relay output standard
- Programmable Run/Stop timer
- Control output On/Off status with timer or manually
- Running status LED for auxiliary outputs
- Temperature bias function (Max 4 zones)
- Heating and cooling control available
- Auto-tuning PID parameter calculation
- Modbus, PC Software, and Sync communications option

Special Features

- High accuracy  $\pm 0.1\%$
- 18 bit A/D converter
- Universal input: TC, RTD, VDC
- Up to three simultaneous outputs



1/16 DIN

Operating Display



► Display output status in Stop mode



► Display control output status (% FS of output)



► Select SP number



► Set alarm 1 value

Value set by user

Terminal Assignment

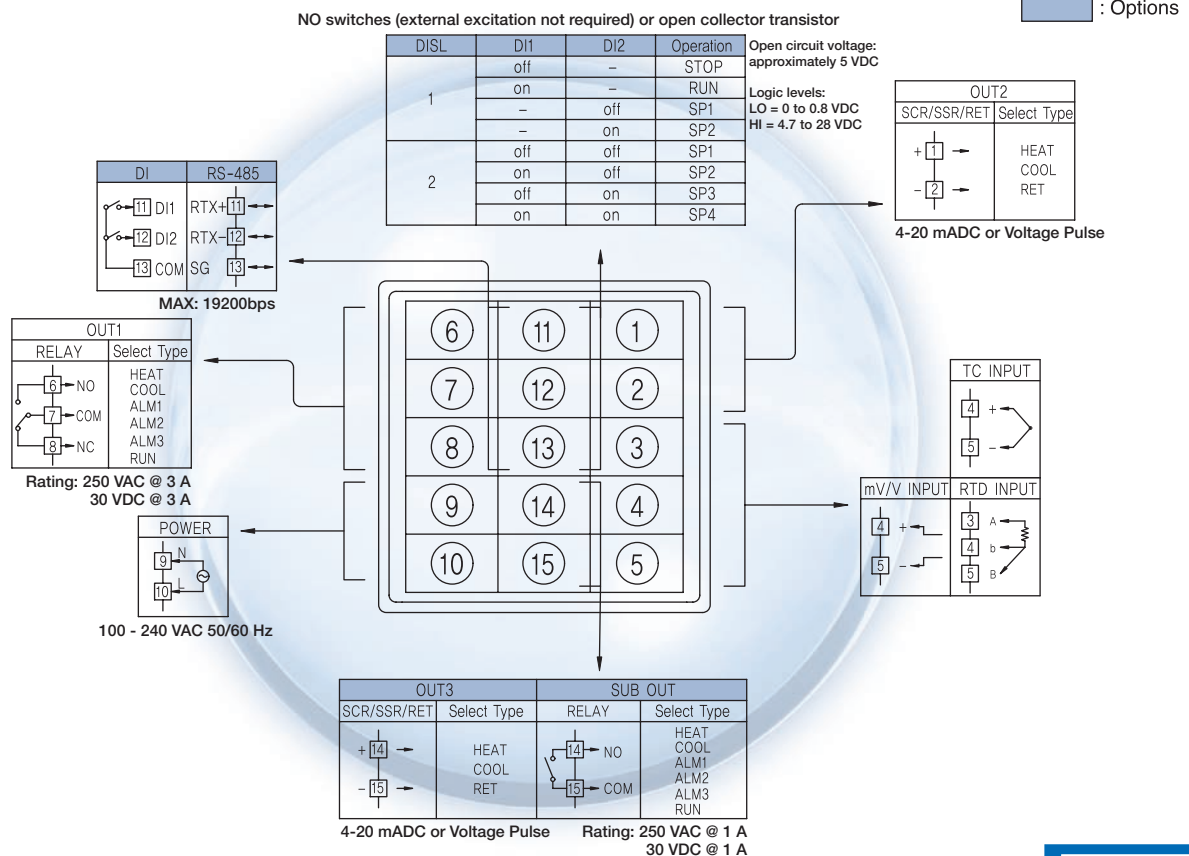



**Digital Controller PD544**

- Dual LED displays show the set point and process variable
- Gain function protects against overshoot
- 1 alarm relay output standard
- Programmable Run/Stop timer
- Control output On/Off status with timer or manually
- Running status LED for auxiliary outputs
- Temperature bias function (Max 4 zones)
- Heating and cooling control available
- Auto-tuning PID parameter calculation
- Modbus, PC Software, and Sync communications option

**Special Features**

- High accuracy  $\pm 0.1\%$
- 18 bit A/D converter
- Universal input: TC, RTD, VDC
- Up to five simultaneous outputs

3/16 DIN

**Operating Display**



► Display output status in Stop mode



► Display control output status (% FS of output)



► Select SP number



► Set alarm 1 value

Value set by user

**Terminal Assignment**

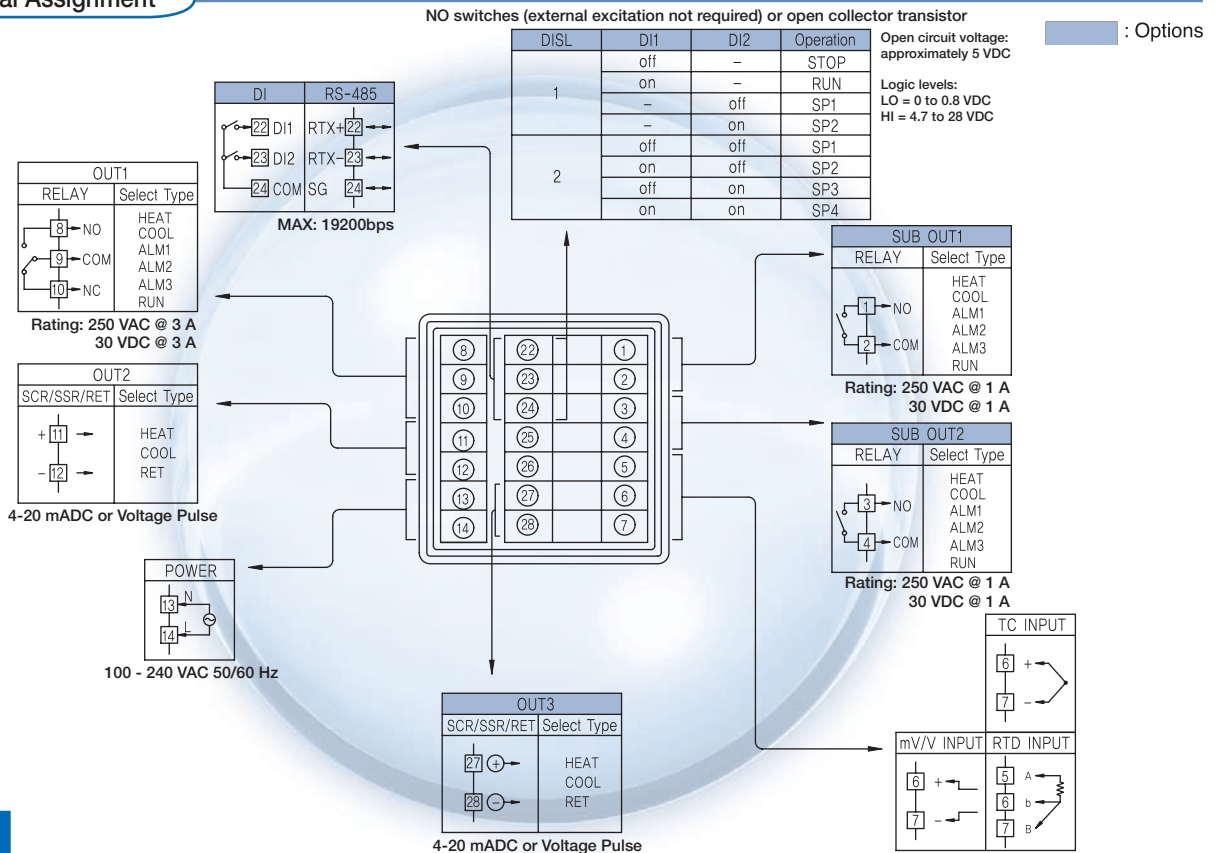



**Special Features**

- High accuracy  $\pm 0.1\%$
- 18 bit A/D converter
- Universal input: TC, RTD, VDC
- Up to five simultaneous outputs



1/8 DIN (H)

**Digital Controller PD542**

- Dual LED displays show the set point and process variable
- Gain function protects against overshoot
- 1 alarm relay output standard
- Programmable Run/Stop timer
- Control output On/Off status with timer or manually
- Running status LED for auxiliary outputs
- Temperature bias function (Max 4 zones)
- Heating and cooling control available
- Auto-tuning PID parameter calculation
- Modbus, PC Software, and Sync communications option

**Operating Display**



► Display output status in Stop mode



► Display control output status (% FS of output)



► Select SP number



► Set alarm 1 value

Value set by user

**Terminal Assignment**

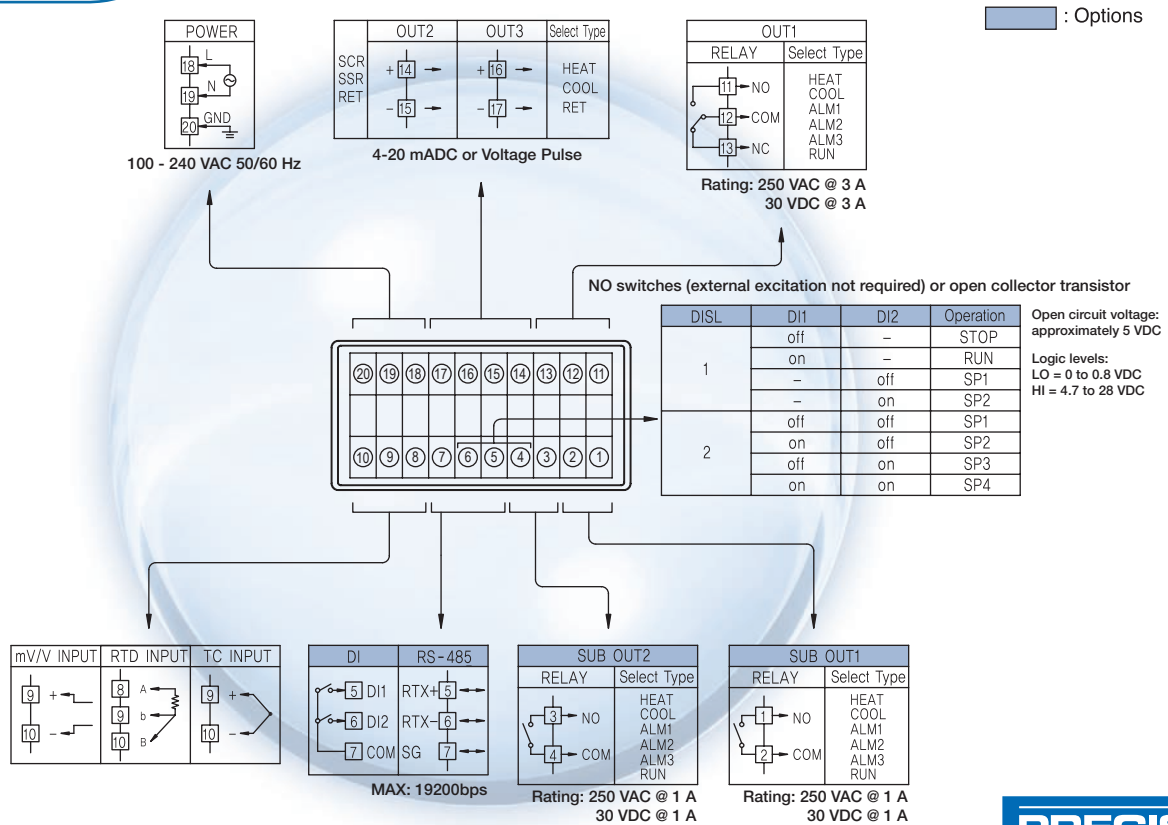



**Digital Controller PD546**

- Dual LED displays show the set point and process variable
- Gain function protects against overshoot
- 1 alarm relay output standard
- Programmable Run/Stop timer
- Control output On/Off status with timer or manually
- Running status LED for auxiliary outputs
- Temperature bias function (Max 4 zones)
- Heating and cooling control available
- Auto-tuning PID parameter calculation
- Modbus, PC Software, and Sync communications option

**Special Features**

- High accuracy  $\pm 0.1\%$
- 18 bit A/D converter
- Universal input: TC, RTD, VDC
- Up to five simultaneous outputs

1/8 DIN (V)

**Operating Display**



► Display output status in Stop mode



► Display control output status (% FS of output)



► Select SP number



► Set alarm 1 value

Value set by user

**Terminal Assignment**

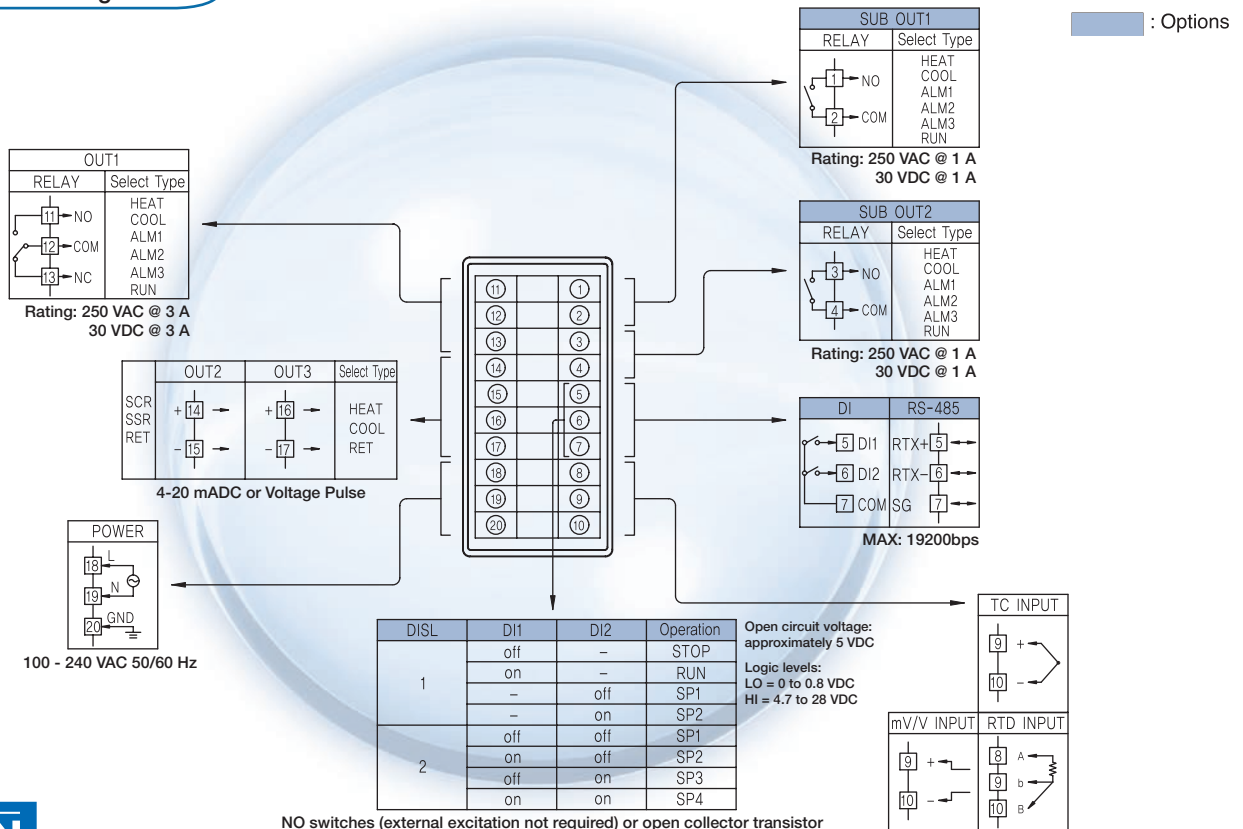



**Digital Controller PD548**

- Dual LED displays show the set point and process variable
- Gain function protects against overshoot
- 1 alarm relay output standard
- Programmable Run/Stop timer
- Control output On/Off status with timer or manually
- Running status LED for auxiliary outputs
- Temperature bias function (Max 4 zones)
- Heating and cooling control available
- Auto-tuning PID parameter calculation
- Modbus, PC Software, and Sync communications option

**Special Features**

- High accuracy  $\pm 0.1\%$
- 18 bit A/D converter
- Universal input: TC, RTD, VDC
- Up to five simultaneous outputs

1/4 DIN

**Operating Display**



► Display output status in Stop mode



► Display control output status (% FS of output)



► Select SP number



► Set alarm 1 value

Value set by user

**Terminal Assignment**

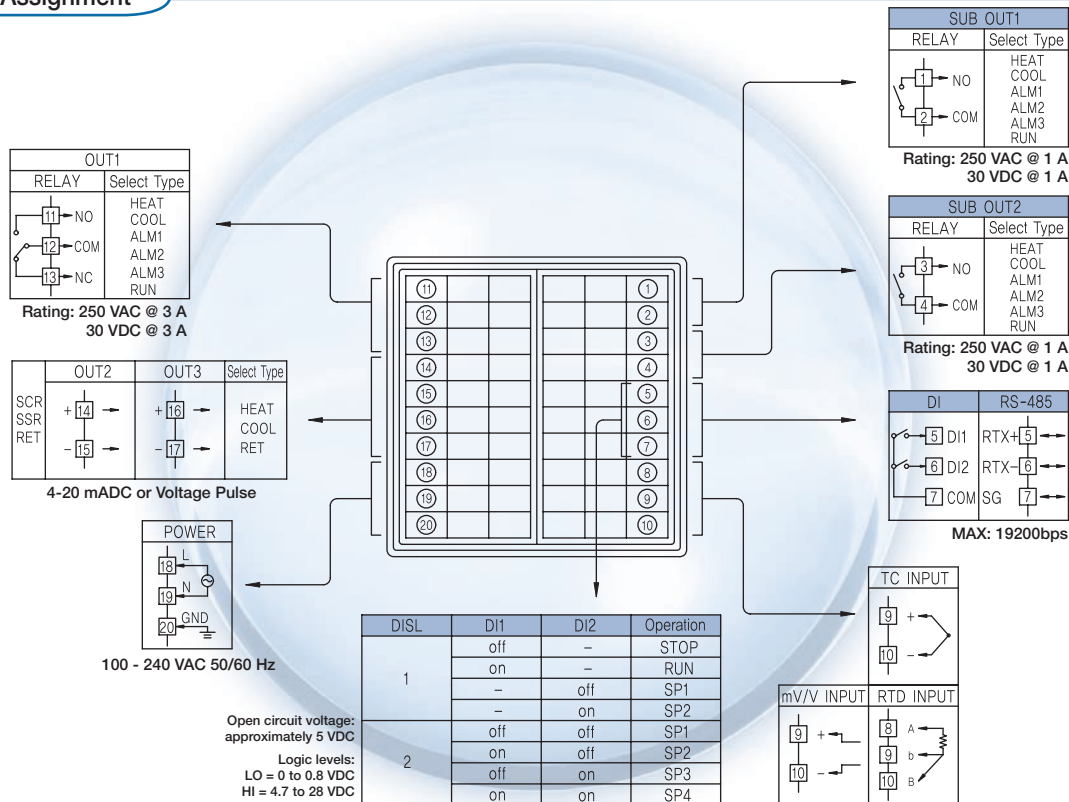

Options



**Programmable Controller PD550**

**Special Features**

- High accuracy  $\pm 0.1\%$
- 18 bit A/D converter
- Universal input: TC, RTD, VDC
- Multiple simultaneous outputs (Max 3)
- Easy to set up parameters and programs
- Gain function to protect against temperature overshoot



1/16 DIN

- Ramp & soak with up to 30 segments
- Two programs with 15 segments each
- Running status LED for auxiliary output
- Variety of auxiliary outputs available (IS, TS, Prog, END)
- Program Run/Stop controlled by Digital Input option
- Temperature bias function (Max 4 zones)
- Auto-tuning PID parameter calculation
- Modbus, PC Software, and Sync communications option

**Operating Display**



► Display output status in Stop mode



► Display control output status (% FS of output)



► Display indicates program running status



► To jump to next program segment: Step = On



► To hold currently running program: "Hold=On"

**Terminal Assignment**

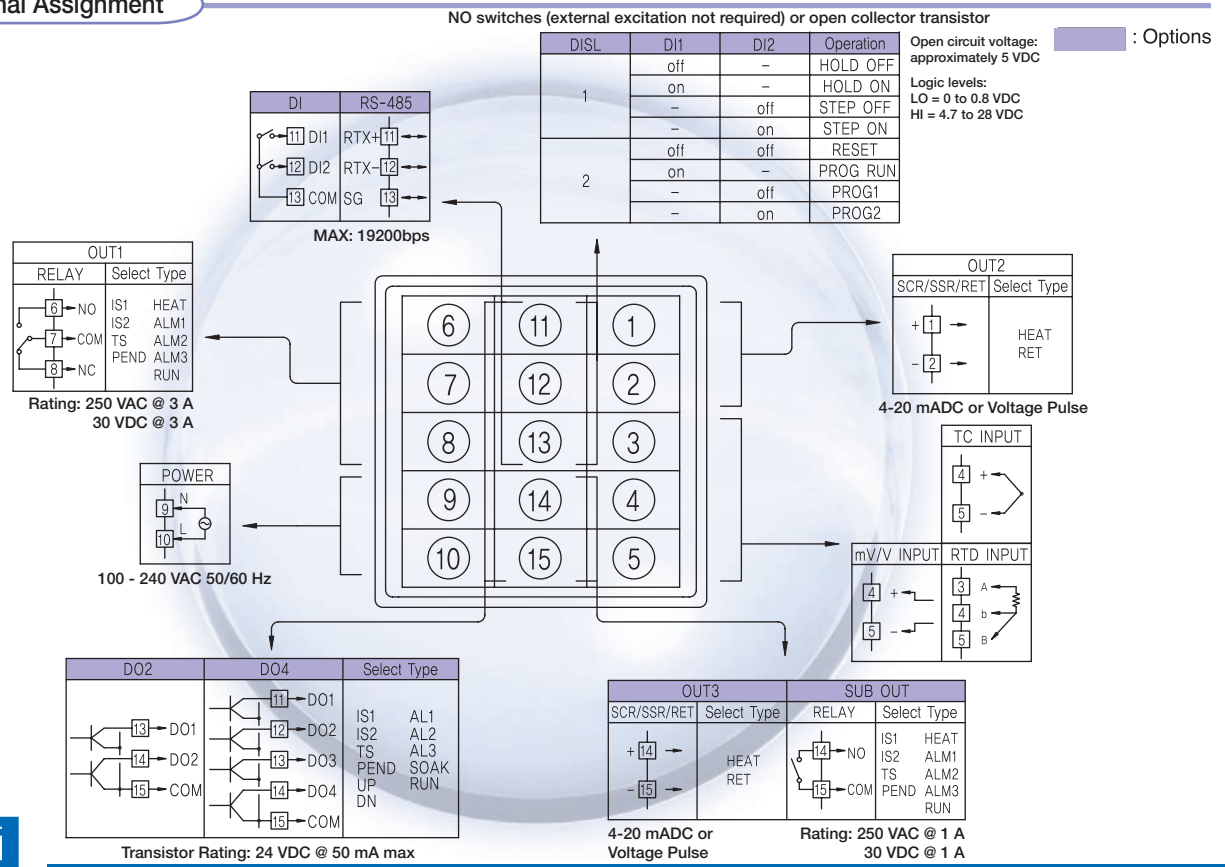



**Programmable Controller PD554**

**Special Features**

- High accuracy  $\pm 0.1\%$
- 18 bit A/D converter
- Universal input: TC, RTD, VDC
- Multiple simultaneous outputs (Max 5)
- Easy to set up parameters and programs
- Gain function to protect against temperature overshoot

- Ramp & soak with up to 30 segments
- Two programs with 15 segments each
- Running status LED for auxiliary output
- Variety of auxiliary outputs available (IS, TS, Prog, END)
- Program Run/Stop controlled by Digital Input option
- Temperature bias function (Max 4 zones)
- Auto-tuning PID parameter calculation
- Modbus, PC Software, and Sync communications option

3/16 DIN

**Operating Display**



► Display output status in Stop mode



► Display control output status (% FS of output)



► Display indicates program running status



► To jump to next program segment: Step = On



► To hold currently running program: "Hold=On"

**Terminal Assignment**

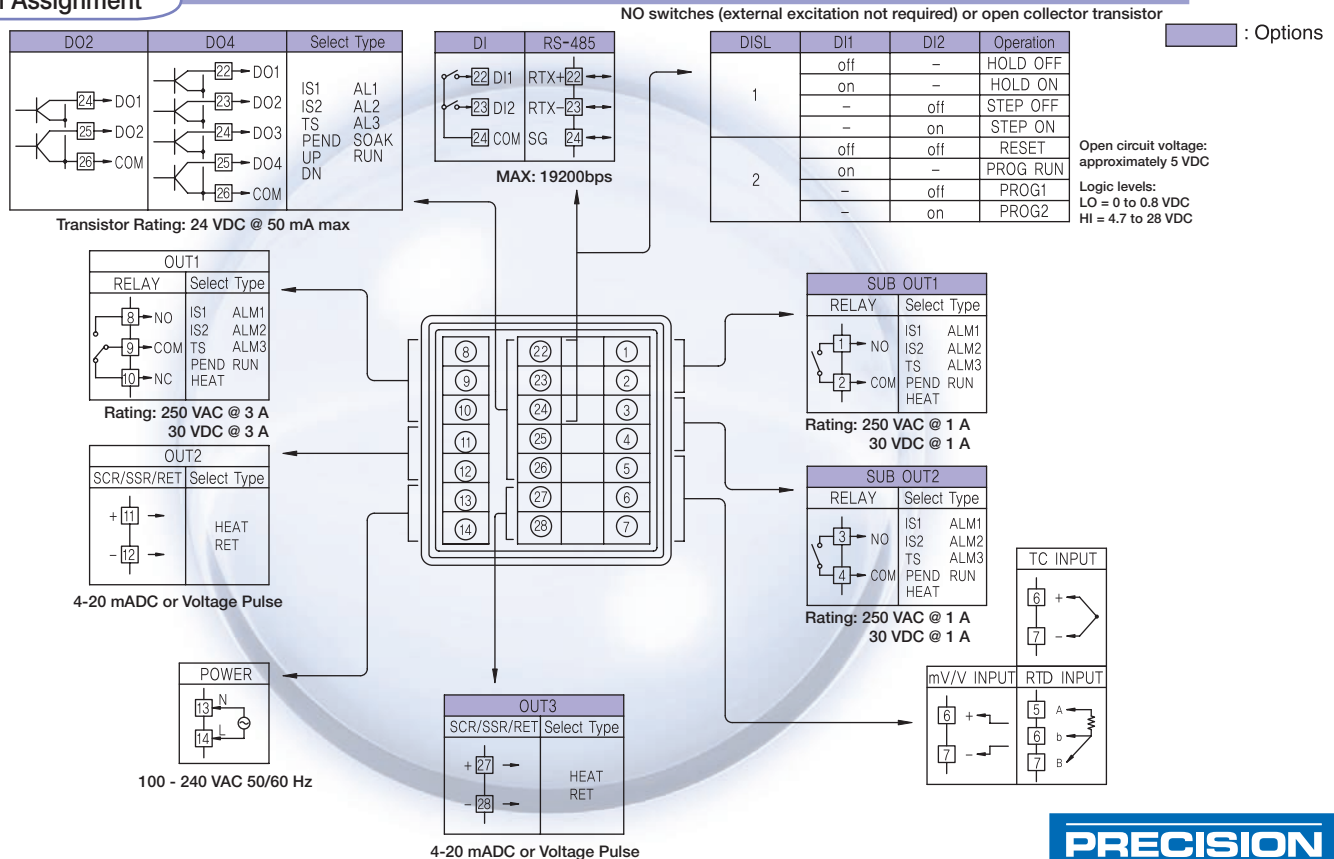



**Programmable Controller PD556**

**Special Features**

- High accuracy  $\pm 0.1\%$
- 18 bit A/D converter
- Universal input: TC, RTD, VDC
- Multiple simultaneous outputs (Max 5)
- Easy to set up parameters and programs
- Gain function to protect against temperature overshoot

- Ramp & soak with up to 30 segments
- Two programs with 15 segments each
- Running status LED for auxiliary output
- Variety of auxiliary outputs available (IS, TS, Prog, END)
- Program Run/Stop controlled by Digital Input option
- Temperature bias function (Max 4 zones)
- Auto-tuning PID parameter calculation
- Modbus, PC Software, and Sync communications option

1/8 DIN (V)

**Operating Display**



► Display output status in Stop mode



► Display control output status (% FS of output)



► Display indicates program running status



► To jump to next program segment: Step = On



► To hold currently running program: "Hold=On"

**Terminal Assignment**

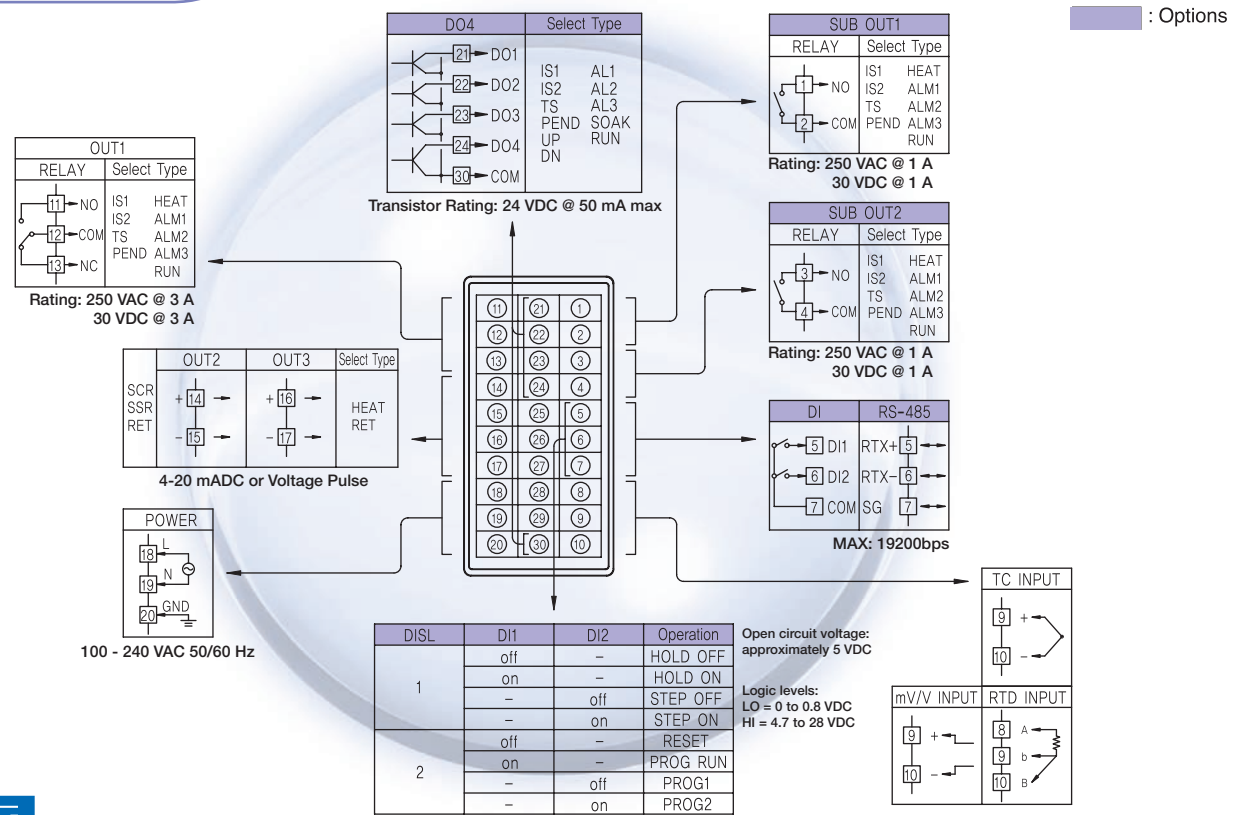

NO switches (external excitation not required) or open collector transistor



**Programmable Controller PD558**

**Special Features**

- High accuracy  $\pm 0.1\%$
- 18 bit A/D converter
- Universal input: TC, RTD, VDC
- Multiple simultaneous outputs (Max 5)
- Easy to set up parameters and programs
- Gain function to protect against temperature overshoot

- Ramp & soak with up to 30 segments
- Two programs with 15 segments each
- Running status LED for auxiliary output
- Variety of auxiliary outputs available (IS, TS, Prog, END)
- Program Run/Stop controlled by Digital Input option
- Temperature bias function (Max 4 zones)
- Auto-tuning PID parameter calculation
- Modbus, PC Software, and Sync communications option

1/4 DIN

**Operating Display**



► Display output status in Stop mode



► Display control output status (% FS of output)



► Display indicates program running status



► To jump to next program segment: Step = On



► To hold currently running program: "Hold=On"

**Terminal Assignment**

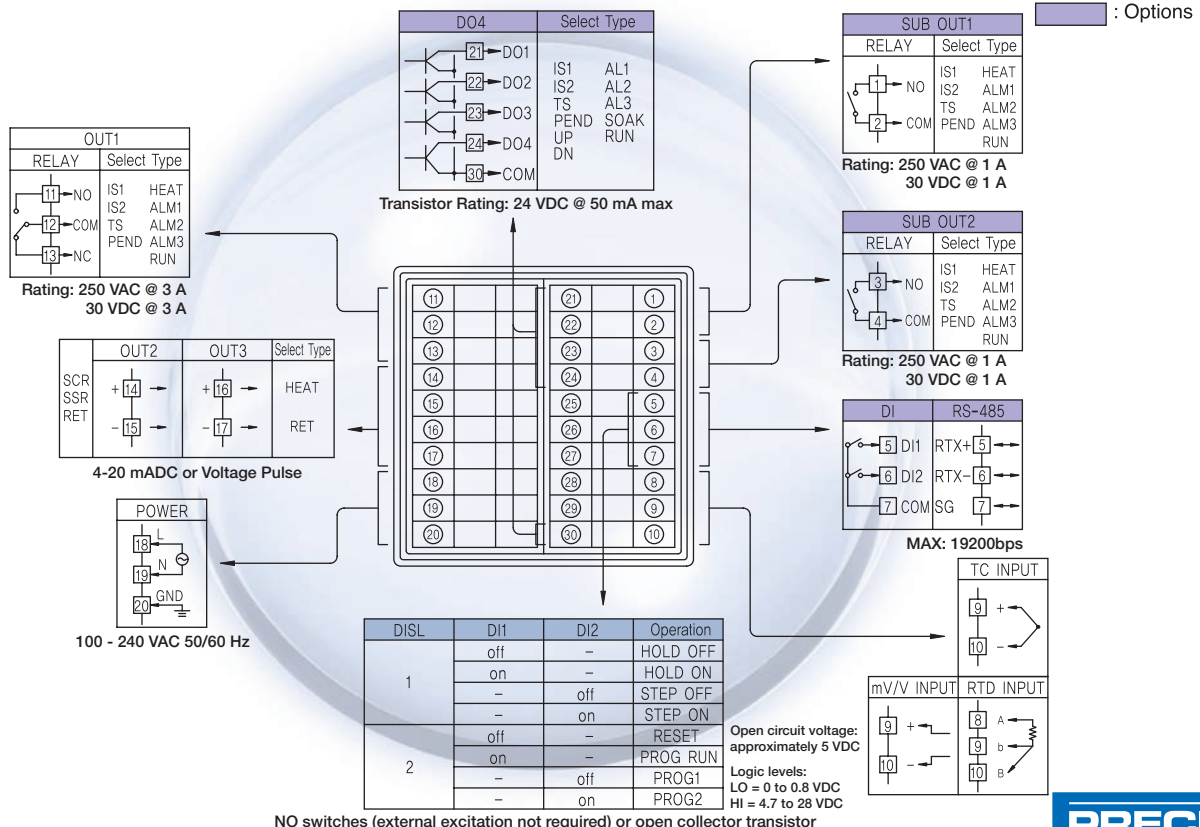



### Special Features

- High accuracy  $\pm 0.1\%$
- Universal input: TC, RTD, VDC
- Alarm relay outputs, max 3
- Easy to set parameters and alarm values



### Digital Meter PD562

- Stores and displays max/min temperature values
- 1 retransmitting and 1 alarm output standard
- Reset function through Digital Input option
- Modbus and PC Software communications option

1/8 DIN (H)

### Operating Display



► Display input value



► Display maximum measured value



► Display minimum measured value

### Terminal Assignment

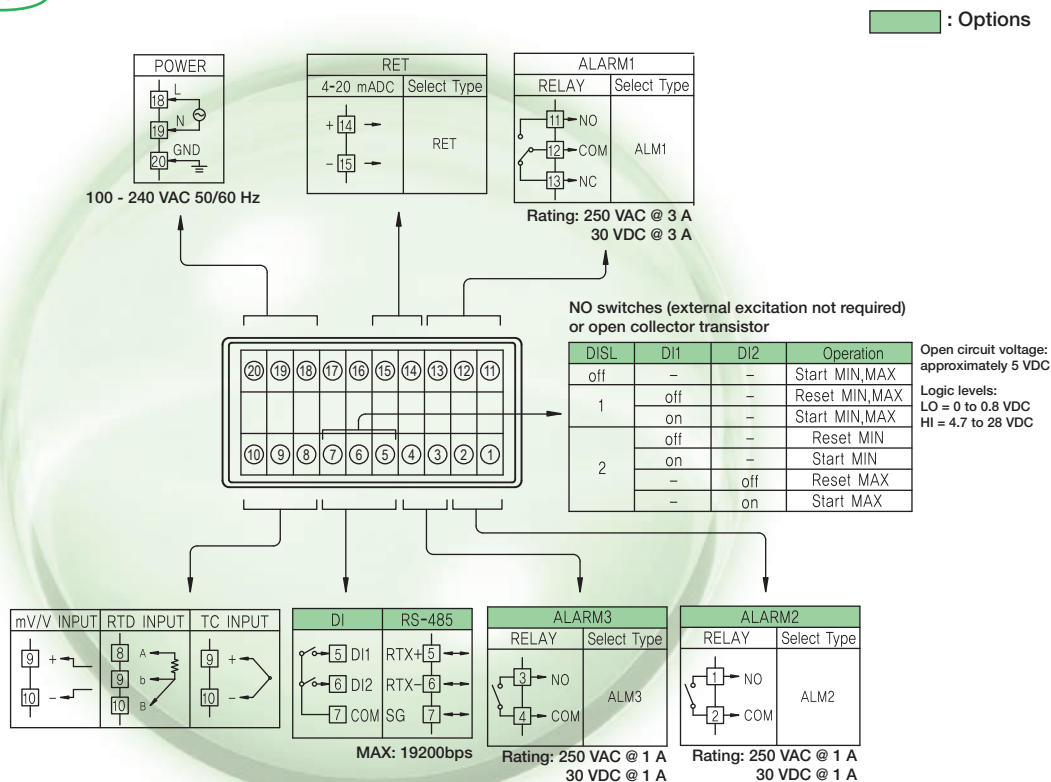



**Special Features**

- High accuracy  $\pm 0.1\%$
- Universal input: TC, RTD, VDC
  - Alarm relay outputs, max 3
- Easy to set parameters and alarm values

**Digital Meter PD568**

- Stores and displays max/min temperature values
- 1 retransmitting and 1 alarm output standard
- Reset function through Digital Input option
- Modbus and PC Software communications option

1/4 DIN

**Operating Display**



► Display input value



► Display maximum measured value



► Display minimum measured value

**Terminal Assignment**

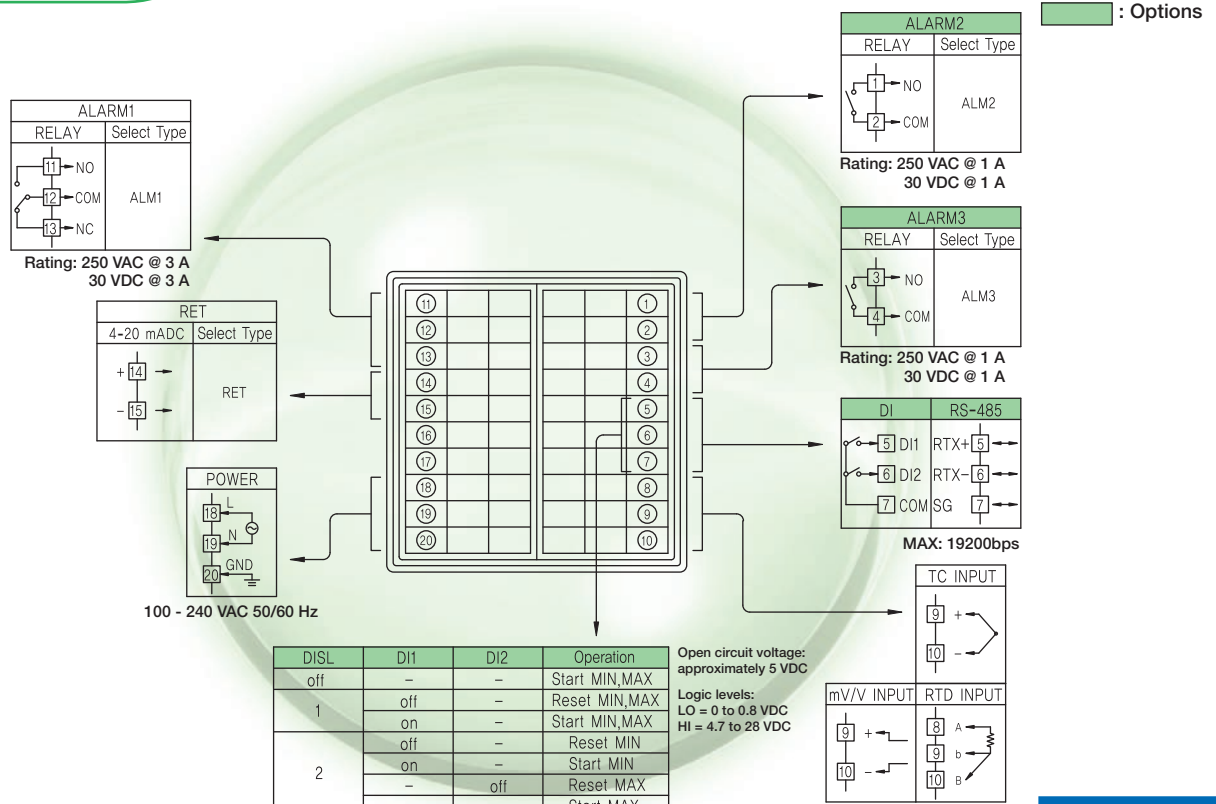



### Special Features

- High accuracy  $\pm 0.1\%$
- Universal input: TC, RTD, VDC
- Relay, latching relay, and 4-20 mA outputs
- Easy to set parameters and alarm values



1/16 DIN

### PD570 Limit Controller

- Limit condition activates a latching relay
- Stores and displays max/min temperature values
- Displays time since relay activation
- Modbus and PC Software communications option

### Operating Display



► Display PV and SP



► Display output status



► Display over limit time



► Display maximum measured input value



► Display minimum measured input value

### Terminal Assignment

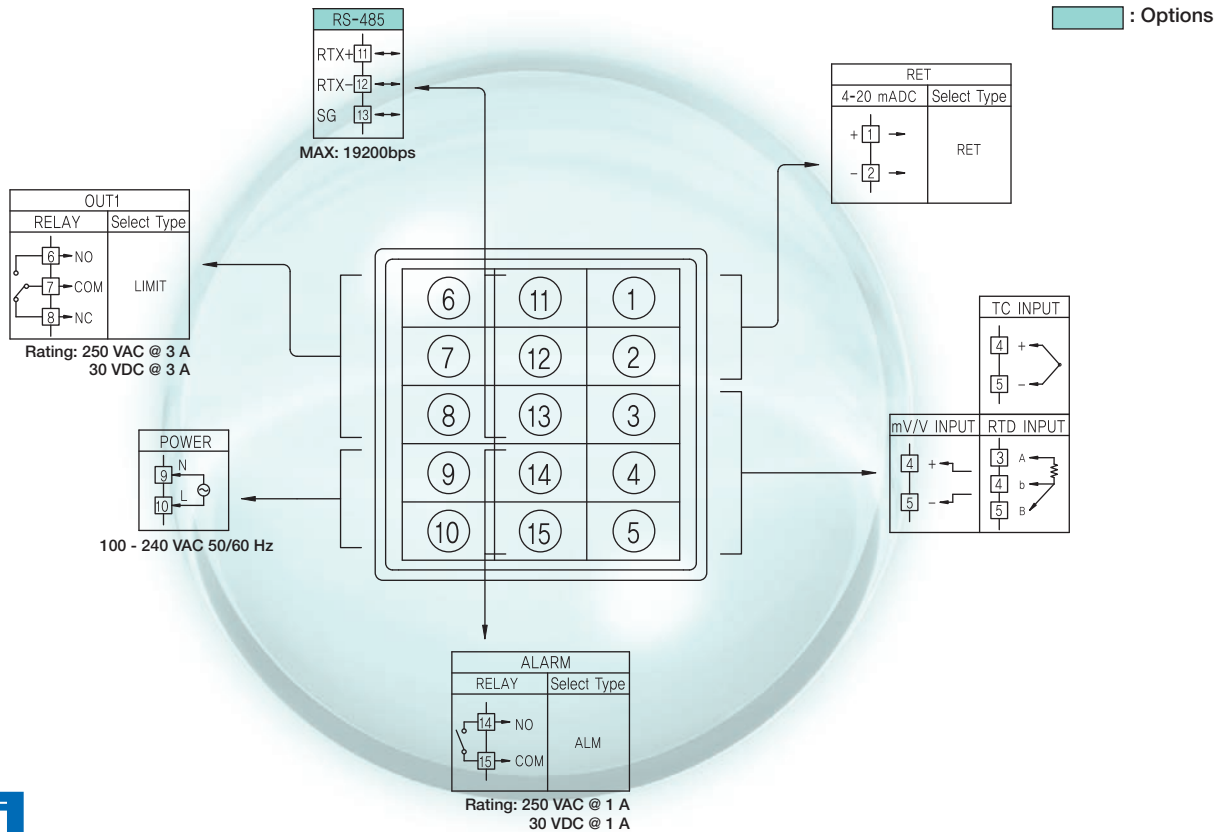



### Special Features

- High accuracy  $\pm 0.1\%$
- Universal input: TC, RTD, VDC
- Relay, latching relay, and 4-20 mA outputs
- Easy to set parameters and alarm values

### PD578 Limit Controller

- Limit condition activates a latching relay
- Stores and displays max/min temperature values
- Displays time since relay activation
- Modbus and PC Software communications option

1/4 DIN

### Operating Display



► Display PV and SP



► Display output status



► Display over limit time



► Display maximum measured input value



► Display minimum measured input value

### Terminal Assignment

   : Options

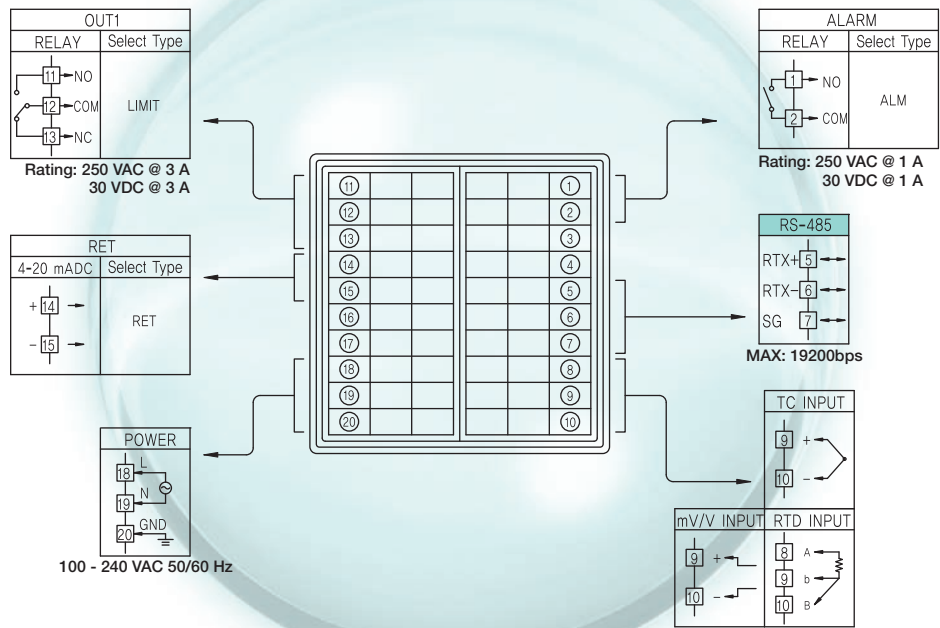

# Dimensions and Panel Cutouts

## 96 X 96 1/4 DIN Controllers

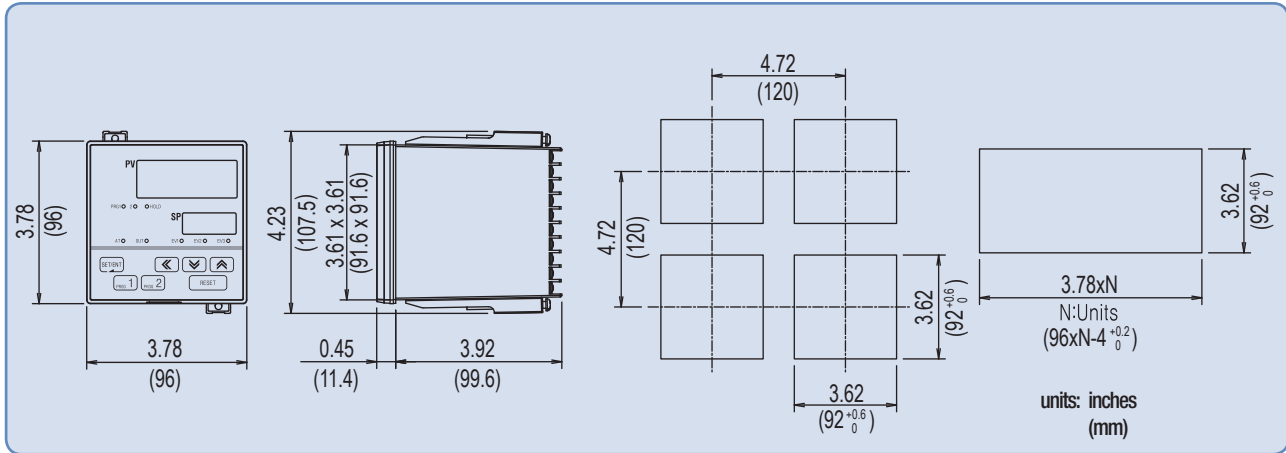

## 48 X 96 1/8 DIN (V) Controllers

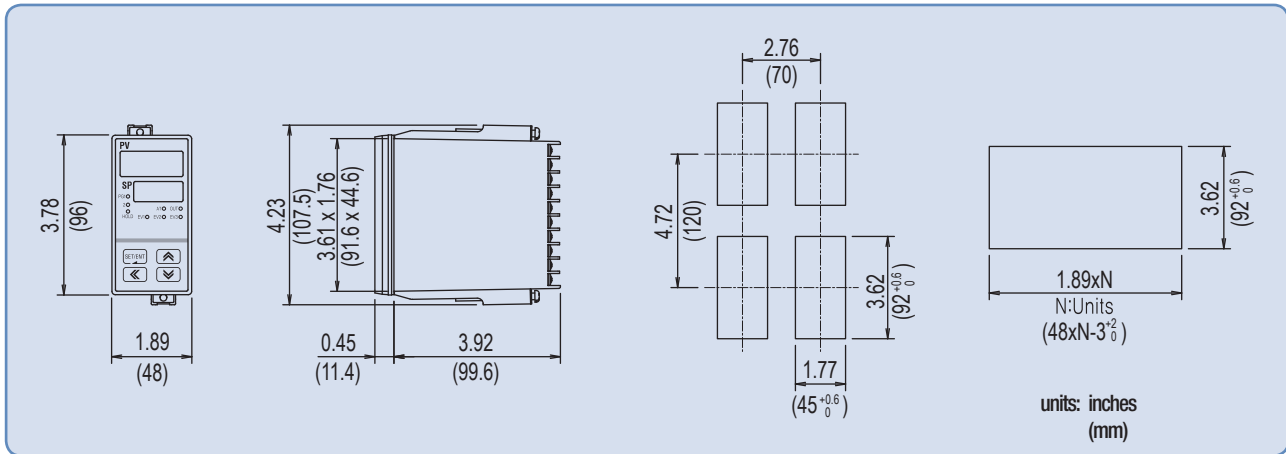

## 48 X 48 1/16 DIN Controllers

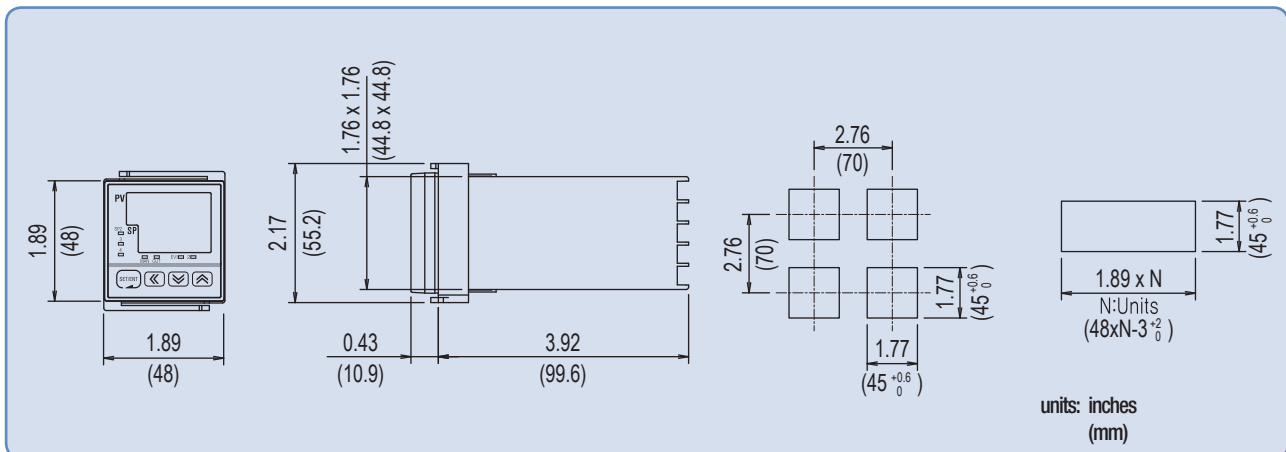

72 x 72 3/16 DIN Controllers

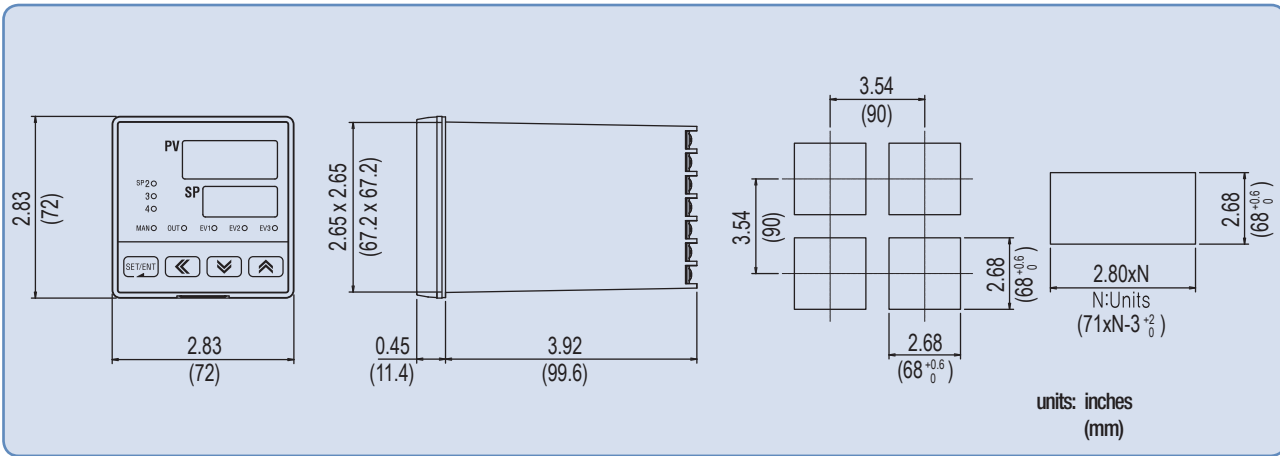

96 x 48 1/8 DIN (H) Controllers

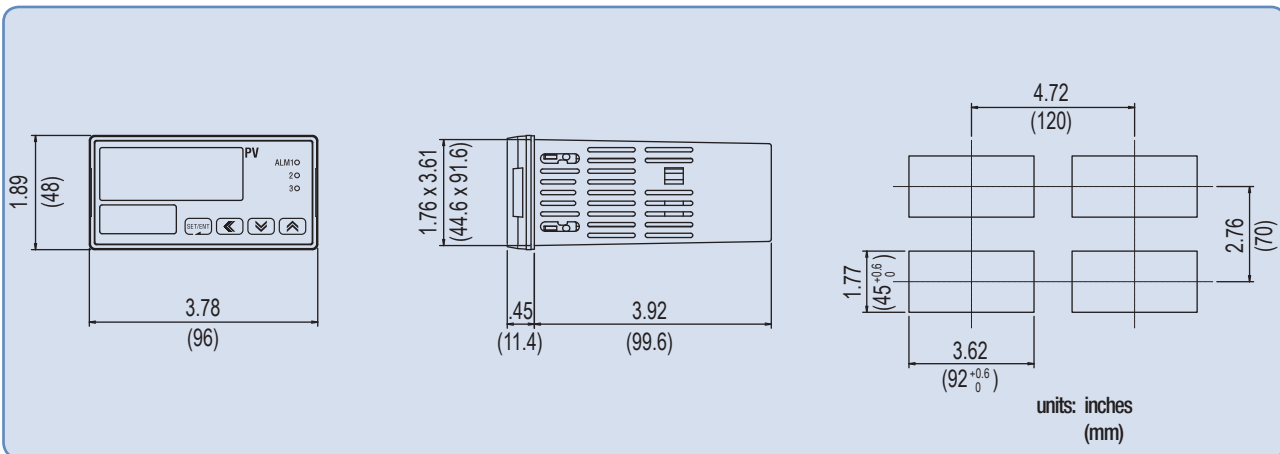

## Precision Digital Custom Enclosures

- Plastic, steel, and stainless steel enclosures
- Explosion-proof enclosures
- Combine Nova Temperature Controllers with other Precision Digital products in one enclosure
- Labels, tags, and mounting kits
- Contact Precision Digital or your local distributor for more information on these and other Precision Digital products



WWW.PREDIG.COM

**PRECISION  
DIGITAL** 

Precision Digital Corporation  
19 Strathmore Road  
Natick MA 01760 USA  
Phone: (800) 343-1001  
Fax: (508) 655-8990

LMDCAT500\_C  
06/05