

VE1101

Vibration diagnostic unit
Connection via M12 x 1 and M8 x 1 connectors

Spectral analysis / FFT
Envelope-curve FFT
Trend analysis

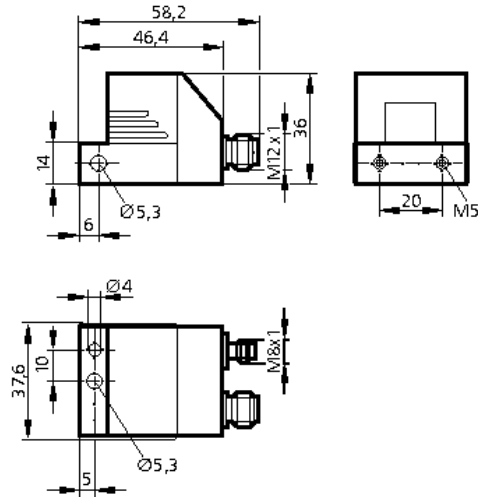

Application	Up to 20 frequencies in the spectrum, freely selectable, diagnostic level adjustable
Electrical design	DC PNP
Operating voltage [V]	10...32 DC
Current consumption [mA]	100 (24V DC) *
Measuring range [g]	± 25 **)
Sensing principle	micromechanical acceleration sensor / capacitive measuring principle / one measurement axis
Overload protection [g]	100
Minimum measuring time [s]	0.8
Frequency range [Hz]	3...6000
Spectral resolution [Hz]	1.25
Monitoring range [rpm]	120...12000 (the actual rotational speed range depends on the type of the rolling element bearing and can therefore differ)

VE1101

Operating temperature [°C]	-30...75
Protection	IP 69K, III
EMC	IEC 1000-4-2/3/4/6
Housing material	housing: diecast zinc

Wiring

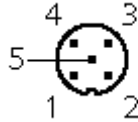

M12
connector
(electrical
connection)
Pin 1: supply +
Pin 2: red function; switching output 2 / 100 mA / NO/NC programmable
Pin 3: supply -
Pin 4: yellow function; switching output 1 / 100 mA / NO/NC programmable
Pin 5: rotational speed, 0...20 mA or pulse input

Wiring

Plug M8 (RS485 communication)

Pin 1: -
Pin 2: B
Pin 3: -
Pin 4: A



Remarks

*) plus optional external pulse pick-up
**) nominal ± 20
Pin 2 (switching output 2) and pin 4 (switching output 1) can only be programmed in pairs