

**VE1001**

Vibration diagnostic unit  
Connection via M12 x 1 and M8 x 1 connectors

Spectral analysis / FFT  
Envelope-curve FFT  
Trend analysis

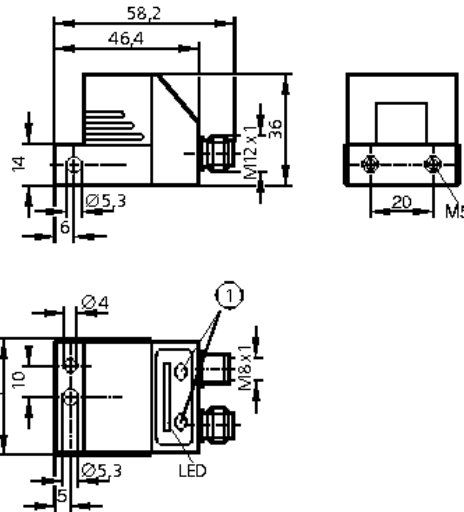

1: Programming buttons

<b>Application</b>	Up to 20 frequencies in the spectrum, freely selectable, diagnostic level adjustable
<b>Electrical design</b>	DC PNP
<b>Operating voltage [V]</b>	10...32 DC
<b>Current consumption [mA]</b>	100 (24V DC) *
<b>Measuring range [g]</b>	± 25 **)
<b>Sensing principle</b>	micromechanical accelerometer / capacitive measuring principle / one measurement axis
<b>Overload protection [g]</b>	100
<b>Minimum measuring time [s]</b>	0.8
<b>Frequency range [Hz]</b>	3...6000
<b>Spectral resolution [Hz]</b>	1.25
<b>Monitoring range [rpm]</b>	120...12000 (the actual rotational speed range depends on the type of the rolling element bearing and can therefore differ)

**VE1001**

Operating temperature [°C]	-30...60
Protection	IP 67, III
EMC	IEC 1000-4-2/3/4/6
Housing material	housing: diecast zinc nickel-plated; keypad: polyester

Wiring

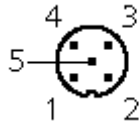

M12 connector (electrical connection)  
 Pin 1: supply +  
 Pin 2: red function; switching output 2 / 100 mA / NO/NC programmable  
 Pin 3: supply -  
 Pin 4: yellow function; switching output 1 / 100 mA / NO/NC programmable  
 Pin 5: rotational speed, 0...20 mA or pulse input

Wiring

M8 connector (RS-232 communication)

Pin 1: -  
 Pin 2: TxD  
 Pin 3: GND  
 Pin 4: RxD



Remarks

\*) plus optional external pulse pick-up  
 \*\*) nominal  $\pm 20$   
 Pin 2 (switching output 2) and pin 4 (switching output 1) can only be programmed in pairs