

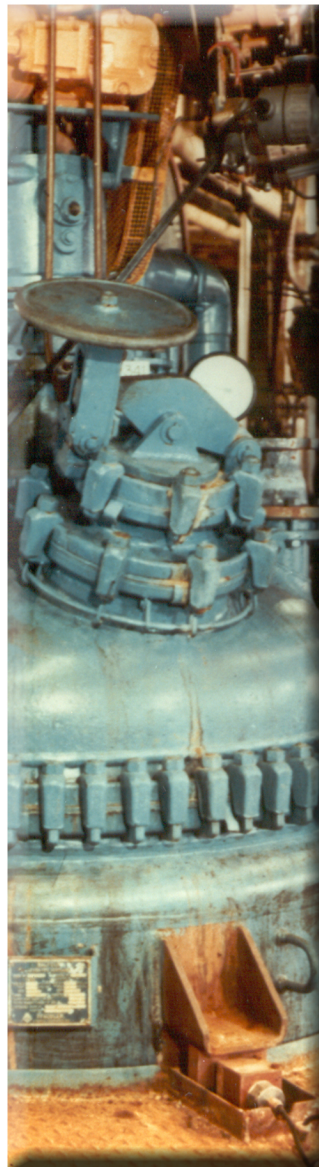

Electronic Weigh Systems Handbook

Third Edition

**Vishay
BLH**



(781) 298-2200

www.vishaymg.com

Handbook 002
2005 Revision

CLICK ON ITEM(S) OF INTEREST

CHAPTER 1 - INTRODUCTION

WHY ELECTRONIC WEIGHING 3

CHAPTER 2 - WEIGH SYSTEM OVERVIEW

ACCURACY VS. REPEATABILITY 5
DEFINITIONS: 5
VESSEL MOUNTING - TENSION OR COMPRESSION 6
VESSEL MOUNTING - COMPRESSION SYSTEM DESIGN FACTORS 7
VESSEL MOUNTING - TENSION SYSTEM DESIGN FACTORS 8
VESSEL MOUNTING - PLANT LAYOUT FACTORS 9
VESSEL MOUNTING - PLANT LAYOUT FACTORS (CONTINUED) 10
VESSEL MOUNTING - NUMBER OF SUPPORTS 11
LOAD CELL (OR WEIGH MODULE) SELECTION 12
LOAD CELL (OR WEIGH MODULE) SELECTION (CONTINUED) 13
LOAD CELL FIELD CALIBRATION 14

CHAPTER 3 - WEIGH MODULE BENEFITS

WEIGH MODULE ACCESSORY OPTIONS 15
WEIGH MODULE INSTALLATION PROCEDURES 16
PREFERRED METHOD - DUMMY BEAM SUBSTITUTION 16
THERMAL EXPANSION CONSIDERATIONS 16
WEIGH MODULE LOAD DISTRIBUTION 17

CHAPTER 4 - UPGARED AND RETROFIT

PRODUCT QUALITY 18
INVENTORY MANAGEMENT 19
REDUNDANT TECHNOLOGY 20

CHAPTER 5 - SYSTEM DIAGNOSTICS

SHIFT TEST 22
DRIFT TEST 22
OVERLOAD TEST 23
DEGRADE MODE FUNCTION 23

CHAPTER 6 - SYSTEM DESIGN FACTORS

INFLUENCE OF VESSEL PIPING AND SUPPORT DEFLECTION 24
VESSEL SUPPORT BRACKET 24
TENSION LINKAGE 25
VESSEL SUPPORT STRUCTURE 25
VESSEL SUPPORT STRUCTURE (CONT.)..... 26
VESSEL SUPPORT STRUCTURE GRAPH 27
PIPING THERMAL GROWTH 28
PIPING SUPPORT DEFLECTION 28
PIPING SUPPORT DEFLECTION DUE TO VESSEL INTERACTION 29
PIPING SUPPORT DEFLECTION DUE TO VESSEL INTERACTION 30
OUTDOOR INSTALLATION RECOMMENDATIONS..... 31
ARC WELDING ON A WEIGH VESSEL 32

CHAPTER 7 - PIPING FLEXIBILITY

DESIGN CRITERIA..... 33
DESIGN CRITERIA (CONTINUED) 34
DESIGN CRITERIA (CONTINUED) 35
DESIGN CRITERIA (CONTINUED) 36
DESIGN ANALYSIS FOR PIPING 37
DESIGN ANALYSIS FOR PIPING (CONTINUED) 38
DESIGN ANALYSIS FOR PIPING (CONTINUED) 39
DESIGN ANALYSIS FOR PIPING (CONTINUED) 40
DESIGN ANALYSIS FOR PIPING (CONTINUED) 41
STIFFNESS OF FLEXIBLE PIPING DEVICES..... 42
STIFFNESS OF FLEXIBLE PIPING DEVICES (CONTINUED) 43
STIFFNESS OF FLEXIBLE PIPING DEVICES (CONTINUED) 44
STIFFNESS OF FLEXIBLE PIPING DEVICES (CONTINUED) 45

CHAPTER 8 - STRUCTURAL DESIGN

SUPPORT DEFLECTION 46
SUPPORT DEFLECTION (CONTINUED) 47
LOAD TRANSDUCER/ SUPPORT BEAM ALIGNMENT 47
DIAGONAL BEAM SUPPORT 48
DIAGONAL BEAM SUPPORT (CONTINUED) 49
VESSEL INTERACTION 49
STIFFENING EXISTING STRUCTURES 50
SUPPORT DETAILS - WEIGH MODULES 51
SUPPORT DETAILS - COMPRESSION LOAD CELLS 52
SUPPORT DETAILS - TENSION LOAD OR S-CELLS 53
HYDRAULIC CALIBRATION ARRANGEMENT 54

CHAPTER 9 - PIPING DESIGN

GENERAL RULES (CONTINUED) 56
SEALED SYSTEMS 56
SEALED SYSTEMS (CONTINUED) 57
SEALED SYSTEMS (CONTINUED) 58
VENTED SYSTEMS 59

CHAPTER 10 - VESSEL DESIGN

VESSEL SUPPORT BRACKETS 60
PROCESS HEATING SYSTEMS 60
VESSELS WITH AGITATORS 60
LIFTING LUGS FOR CALIBRATION WEIGHTS 61
SADDLE SUPPORTS FOR HORIZONTAL TANKS ON LOAD CELLS AND BEARING BEAMS 61
VESSEL TARE-TO-LIVE WEIGHT RATIO 61
VESSELS WITH NON-LEVEL MATERIAL 61
VESSELS SUSPENDED BY SINGLE TENSION CELL 62
VESSELS LOCATED IN TRAFFIC AREAS 62

CHAPTER 11 - WIRING DESIGN

FLEXIBLE CONDUIT 63
DO NOT SHORTEN THE LOAD CELL/WEIGH MODULE CABLE 63
DO NOT SHORTEN THE LOAD CELL/WEIGH MODULE CABLE (CONTINUED) 64

CHAPTER 12 - LOAD CELL CONSIDERATIONS

LATERAL RESTRAINTS - STAY RODS, SAFETY CHECK RODS 65
PARTIAL LISTING OF OPERATIONAL AND ENVIRONMENTAL ELEMENTS
ACTING TO DISTURB A VESSEL... 65
LATERAL RESTRAINTS - STAY RODS, SAFETY CHECK RODS (CONTINUED) 66
LATERAL RESTRAINTS - STAY RODS, SAFETY CHECK RODS (CONTINUED) 67
LATERAL RESTRAINTS - STAY RODS, SAFETY CHECK RODS (CONTINUED) 68
LATERAL RESTRAINTS - STAY RODS, SAFETY CHECK RODS (CONTINUED) 69
LATERAL RESTRAINTS - STAY RODS, SAFETY CHECK RODS (CONTINUED) 70
LATERAL RESTRAINTS - STAY RODS, SAFETY CHECK RODS (CONTINUED) 71
ACCESSORY SELECTION AND INSTALLATION 72
LOAD CELLS IN COMPRESSION 73
LOAD CELLS IN COMPRESSION (CONTINUED) 74
ACCESSORY SELECTION AND INSTALLATION 75

CHAPTER 12 - LOAD CELL CONSIDERATIONS (CONTINUED)

ACCESSORY SELECTION AND INSTALLATION 76
LOAD AND "S" CELLS IN TENSION 79
LOAD AND "S" CELLS IN TENSION 80
INSTALLATION SEQUENCE FOR COMPRESSION LOAD CELLS 80
PREFERRED METHOD - RECOMMENDED FOR HIGH ACCURACY SYSTEMS..... 80
ALTERNATE METHOD - SUITABLE FOR LOWER ACCURACY SYSTEMS 81
EXPANSION ASSEMBLIES FOR COMPRESSION LOAD CELLS 81
LOAD DISTRIBUTION FOR COMPRESSION LOAD CELLS..... 81
SHIM FOR LOAD DISTRIBUTION 81

CONCLUSION

FIELD SERVICE ENGINEERING 82
VISHAY TRANSDUCERS SALES OFFICES WORLD WIDE 82

Since the beginning of trade, some kind of measure of weight had to be established. Not only did this measure have to be uniform, it also had to be honest. The equal arm balance scale or the unequal arm beam scale has been used for thousands of years as the standard for comparison. It is still, by far, the most commonly used technique in the world for determination of weight. However, approximately, sixty five years ago a novel technique was invented to make electronic weight measurements reliable and economically practical. This invention was the resistance wire strain gage. The strain gage consists of a filament of thin foil or wire which will change resistance when stretched or compressed.

Dr. Arthur C. Ruge of M.I.T. and E. E. Simmons of CalTech are credited with the simultaneous, but independent invention of the strain gage in 1937/38. Since each inventor had an assistant working on their project, and, since a total of four people worked on the invention, the trade name for this strain gage became SR-4® (Simmons Ruge - 4 people).

Professor DeForest, an inventor in his own right, encouraged Dr. Ruge in his work. From this relationship between two educators/scientists grew the Ruge-DeForest partnership that manufactured strain gages sold by Baldwin in the 1940's.

When a strain gage is bonded to a piece of metal and the metal is loaded with a weight or force, the resistance change of the strain gage can be related directly to the weight or force placed on this piece of metal. The first industrial load, pressure and torque transducers using the strain gage technique were developed by Ruge in 1942 and 1943. Unlike today's high precision load transducers, the early cells were accurate only to 0.25% of full scale and available in limited weight capacities.

Load transducers (cells) are now universally accepted. Vishay BLH has thousands of strain gage-based weighing system installations all over the world. The intent of this handbook is to help users avoid problem situations that degrade the accuracy of a weighing system. Many suggestions in this handbook come from the Vishay BLH Field Service Group.

Vishay BLH is part of the Vishay Transducers division of Vishay Measurements Group. Vishay Measurements Group develops, manufactures, and markets a broad range of sensors for a wide variety of test and measurement applications. These include electrical resistance strain gages for both stress analysis testing and transducer manufacturing applications, instrumentation, hybrid strain gage assemblies and transducers for OEM applications and certified load cells for electronic scales and other weighing applications. Vishay Measurements Group is part of Vishay Intertechnology.

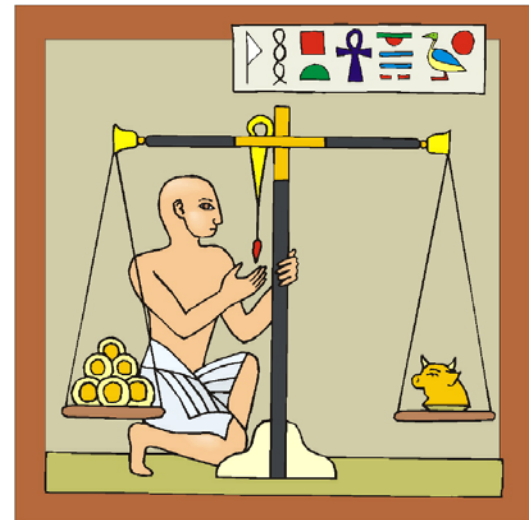

Since the beginning of trade, some kind of measure of weight had to be established... it also had to be honest.

The term 'electronic weighing' as used in this book is based upon the load cell (transducer), which derives its principals from the strain gage. Typical load cells consist of an elastic element to which strain gages are bonded. Upon applying the mass to be measured to the elastic member, the strain gage will change its resistance in direct proportion to the mass applied. Load cells, therefore, are electronic devices that translate changes in force into changes in resistance. This change in resistance is measured, monitored, and subsequently displayed on a transducer indicating instrument or transmitted to a higher end system control device.

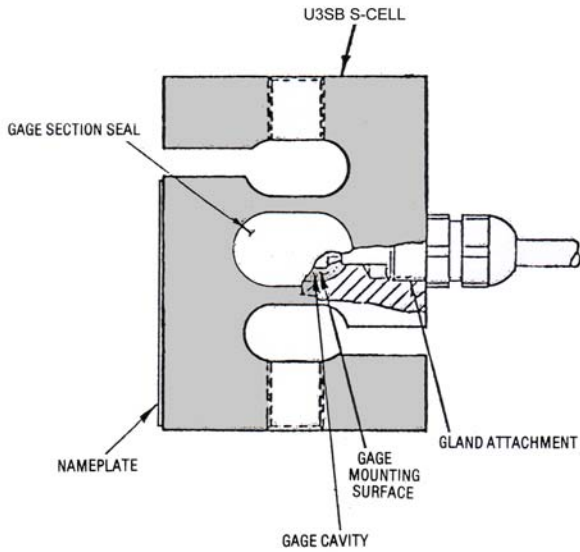

S-Cell Construction

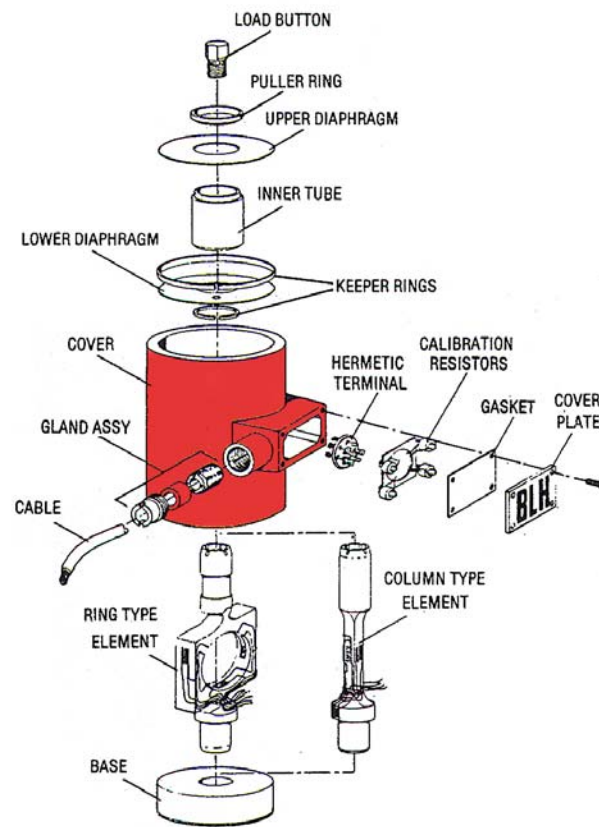

Canister Cell Construction

Typical load cell, KIS beam, and S-cell construction is shown in these illustrations.

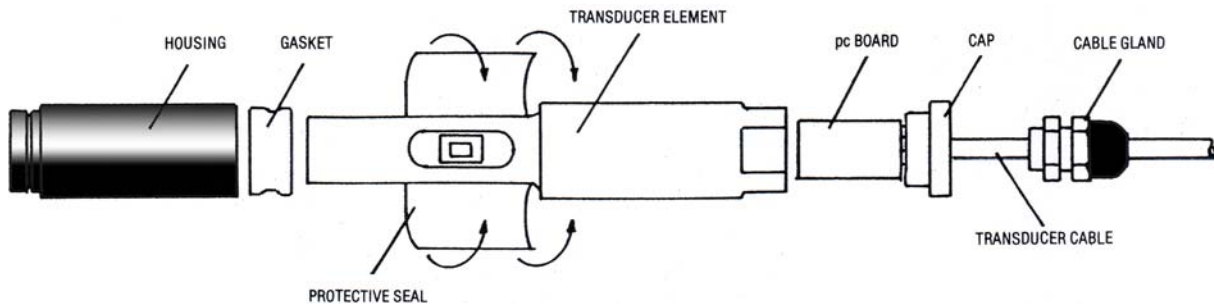

Double Cantilever Beam Construction

Four SR-4® strain gages are used in each load transducer and connected in a fully active, four-arm Wheatstone bridge. Precision resistors are added at different locations in the circuitry to compensate for temperature effects. Typical standard compensated values for load transducers are eight parts per million (ppm) per degree Fahrenheit for the output change with temperature and fifteen ppm/°F for the zero change with temperature. In order to protect the element from the outside environment, the sensing portion of the load transducer is enclosed in a sealed cover. Each load transducer sold by BLH has special inherent features to protect the sensing element from the effects of side loading.

Why electronic weighing

The majority of electronic weighing systems are used for one of the following purposes:

REDUCE INVENTORY COSTS- Efficient and accurate control of inventory by weight allows the user to maintain the optimum amount of material on hand for efficient production without costly excesses. Accurate inventory can also result in a reduced number of storage vessels and area, contributing to further cost savings.

REDUCE LABOR COSTS - Process automation through installation of automatic batching systems can eliminate a substantial amount of manual input. Centralized inventory control readouts obviate the need for visual inspection of storage areas.

IMPROVE PRODUCT QUALITY-Accurate batch control improves the consistency of end product quality resulting in improved product acceptance and reduces costly product rejects and rework. It is easily understood why an electronic weigh system has advantages over a mechanical beam type system. Some of the advantages are:

- 1) **Due to the low deflection of the load transducer, a load transducer based weighing system has a fast response or settling time.**
- 2) **The higher the capacity of the weighing system, the lower the cost will be of the weighing structure.**
- 3) **Remote measurements can be made.**
- 4) **The weight information can be processed directly to eliminate human error.**
- 5) **Microprocessor based instruments communicate directly with programmable controllers and distributed control systems.**
- 6) **Electronic weighing systems often can be adapted to existing installations.**
- 7) **Load transducers and associated electronics are solid-state devices and, therefore, are not subjected to wear such as found in the knife edges, supports and flow meter paddle wheels used in other systems.**

ELECTRONIC WEIGHING SYSTEMS:

Reduce inventory costs

Reduce labor costs

Improve product quality

In its simplest form, a weigh system consists of a vessel whose contents are to be monitored, load cells or weigh modules* that generate a signal proportional to the vessel weight, and an electronic device to power, amplify, interpret and display the signal. However, the accuracy of such a system, while obviously a function of the instrumentation, is also dependent upon the vessel design (reactor, batch tank, inventory silo, etc.), support structure, piping attachments, lateral restraint system, vessel environment (temperature, traffic, nearby equipment), and proper selection of transducer accessories. In short, weigh system accuracy is inexorably tied to the degree of attention given to the mechanical details and vessel functionality.

HIGH ACCURACY, PROCESS WEIGHING SYSTEMS exhibit system errors under 0.05% for Buy-and-Sell to 0.25%. Precision load cells or weigh modules with full temperature compensation must be used. To achieve this, the following mechanical requirements are imposed:

The weigh vessel must be fully supported by load cells/weigh modules. The number of load cells/weigh modules may vary from one (in tension) to eight (in compression). Generally, as the number of load cells decreases, the vessel wall thickness and support structure stiffness must increase to carry the higher vessel support reactions lest vessel deformation cause calibration errors.

Mechanical restrictions from attached piping and lateral restraints should be avoided. Highly flexible piping attachments are recommended.

Hot gas or steam-heating schemes which produce variable buoyancy should be avoided. Consult factory for alternate solutions.

LOW ACCURACY INVENTORY WEIGHING SYSTEMS are those with a system error greater than 0.5%. General purpose cells/modules are satisfactory for these systems. Mechanical considerations are relaxed considerably:

The weigh vessel need only be partially supported by load cells/weigh modules, usually one or two on any side or end of the vessel. This, however, requires the contents to be self-leveling and the vessel itself to be without partitions, so that the load fraction carried by the load cells/modules is unchanging. (Vessels falling into these two categories must be fully supported, independent of the accuracy required.)

Modest mechanical restrictions may be tolerated, but nonlinear mechanical hang-ups or frictional interfaces must still be avoided.

*weigh module = load cell plus integral mounting hardware

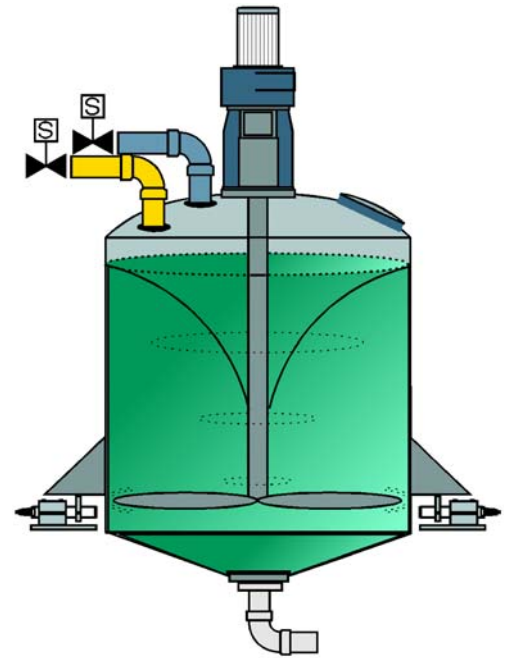

High accuracy, batch processing tank fully supported by KIS Weigh Modules

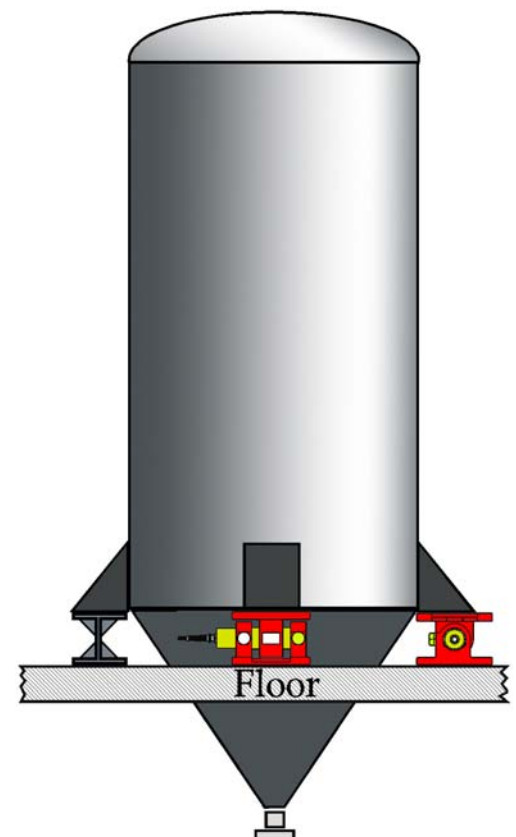

Lower accuracy storage silo partially supported by KDH Weigh Modules

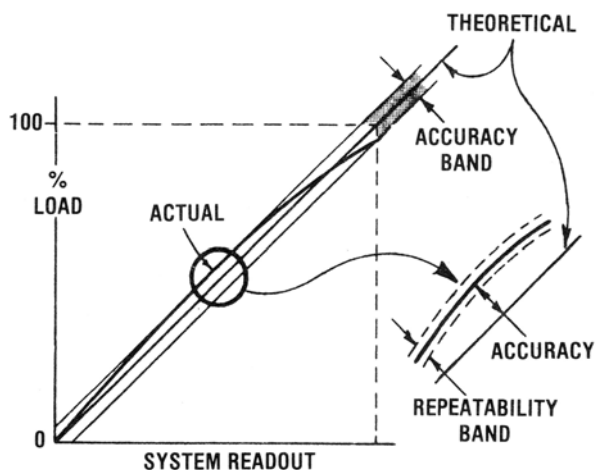

Accuracy vs. repeatability

DO NOT CONFUSE SYSTEM ACCURACY WITH REPEATABILITY! As long as the mechanical error in a given system is linear with deflection and independent of the environment (temperature, traffic, surrounding vessels, etc.), the inherent system repeatability will be greater than its accuracy. For example, Vishay BLH Transducer Indicators typically have an overall accuracy specification of 0.01 % of reading, ± 1 count (or better), of which repeatability is but a small fraction. BLH load transducers, meanwhile, typically display a repeatability of 0.01 to 0.02%. Thus, most BLH systems will be repeatable within 0.03% of full scale, independent of how the system is calibrated. For most batching operations, repeatability is essential, whereas accuracy (actual pounds used) is of secondary importance once the operating parameters have been established. Field calibration, when required, is generally done by electronic simulation.

For buy-and-sell installations, where distribution is by weight, calibration and repeatability are essential; field calibration is always performed employing a dead weight method.

DEFINITIONS:

ACCURACY - Ability of the system to perform weighing functions within an acceptable or desirable tolerance; usually stated as a percentage of either full-scale reading, or $\pm n$ count(s) referred to the total number of scale divisions.

REPEATABILITY - The ability of the system to read the same value when the measured weight is applied repeatedly in the same manner with the same quantity under constant conditions.

Maximum accuracy and repeatability is obtained by placing high accuracy load cells/modules at all support points and connecting them to instrumentation that measures each cell/module individually.

For most batching operations, repeatability is essential, whereas accuracy (actual pounds used) is of secondary importance

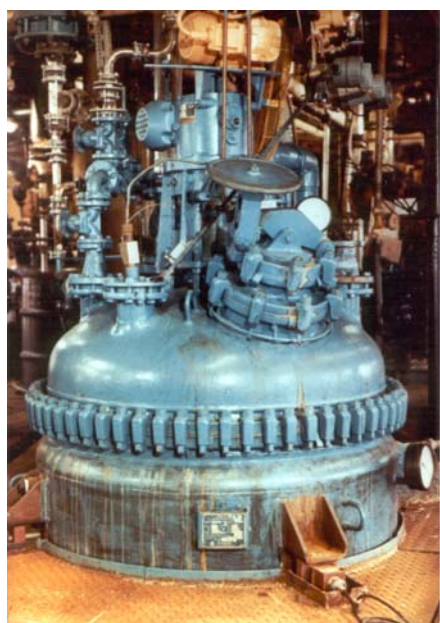

Vessel mounting - tension or compression

Either method routinely yields high accuracy weigh systems and, except for the few observations presented below, there is little to recommend one over the other. In most cases, plant layout is the determining factor.

MAXIMUM WEIGH SYSTEM ACCURACY AND STABILITY will be obtained when the vessel is mounted in compression or tension to a rigid foundation. This arrangement avoids all the usual sources of deflection, variations in load transducer alignment, and vibration that act to compromise calibration accuracy and operational stability. Therefore, when extreme accuracy is required (<0.05%), this approach should be considered first.

SUSPENDED VESSELS are candidates for the simplest system, a single canister type load or S-Cell (Vishay BLH Model U3SB) in tension - providing that lateral restraints may be added if required to keep the vessel from tilting, swaying, and rotating.

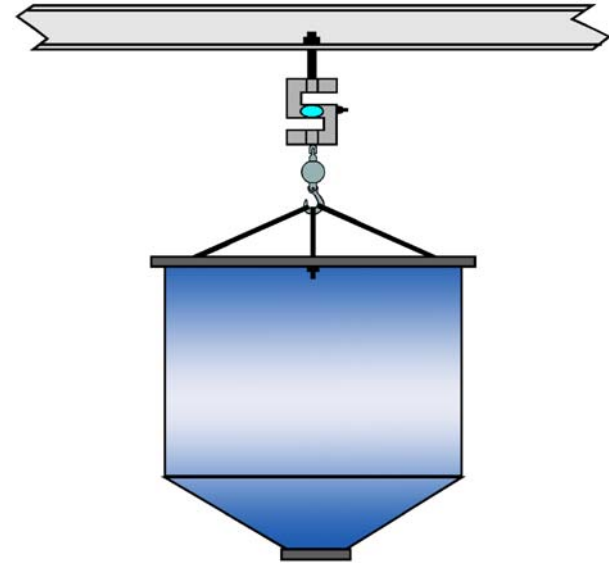

Simple, single U3SB tension mount system

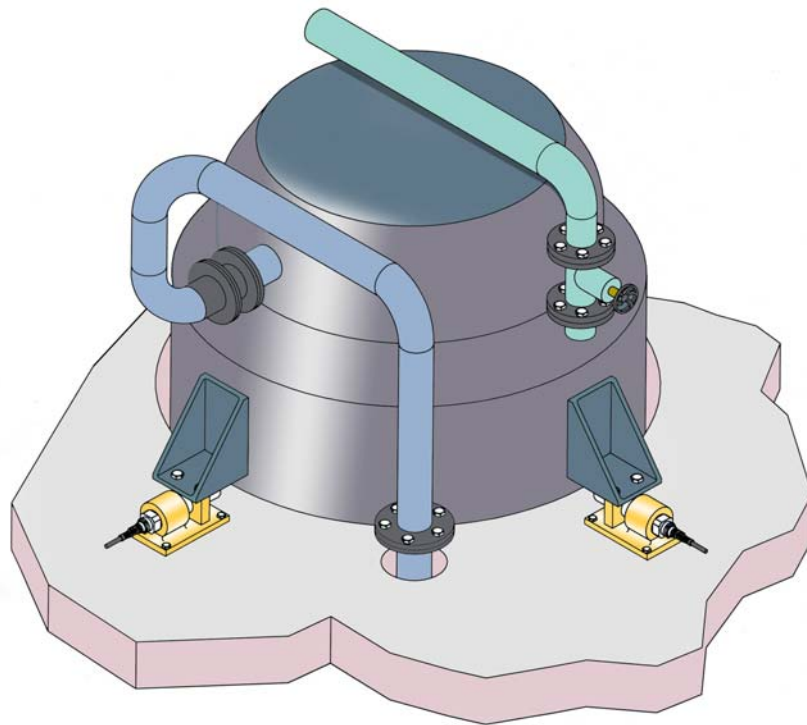

Precision compression system with KIS Weigh Modules mounted on concrete floor

Vessel mounting - compression system design factors

WEIGHT LIMIT

Unlimited, although the number of vessel supports typically should not exceed eight. Beyond eight, load distribution among the supports becomes very difficult. If eight or more supports are involved, make certain that system instrumentation is capable of handling the extra load cell/module power requirements.

LOAD CELL ALIGNMENT

Canister type load cell alignment may vary during operation due to overall floor deflection, local support beam twist.

VESSEL NOT AT CONSTANT AMBIENT TEMPERATURE

Low friction expansion assemblies (canister type cells) or weigh module design compensation is required to accommodate differential thermal expansion and contraction between the vessel and support structure. Thermal insulation pads minimize heat conduction to load transducers.

LATERAL RESTRAINTS

Lateral restraints are always necessary for canister type load cells. Lateral restraints are usually unnecessary in weigh module design applications. Integral mounting hardware design typically accommodates upturning, wind force, and seismic fluctuation moments.

SENSITIVITY TO STRUCTURAL SUPPORT VIBRATION

A function of the stiffness of the structure and vessel support structures. Mechanical and/or electrical filtering (dampening) may be required to eliminate measurement distortions.

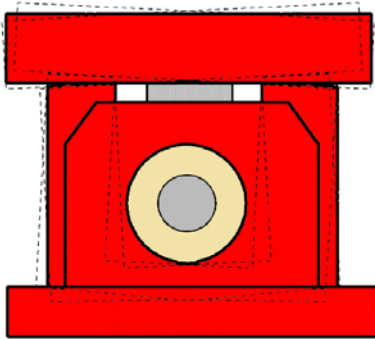
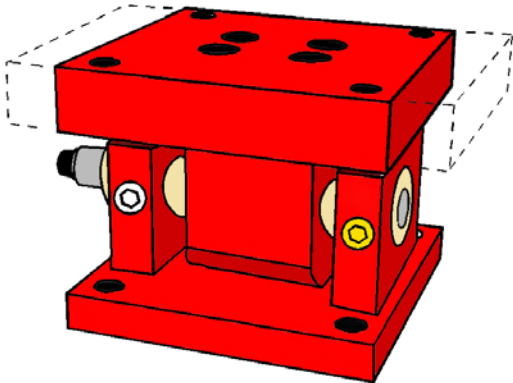

Lateral restraints are usually unnecessary in weigh module design applications. Integral mounting hardware design typically accommodates upturning, wind force, and seismic fluctuation moments.

Weight limit is unlimited, although the number of vessel supports typically should not exceed eight



Vessel mounting - tension system design factors

SAFE WEIGHT LIMIT

Usually designed to 10,000 - 20,000 pounds gross weight since the structural reinforcement required for higher values becomes expensive. However, installations to 50,000 pounds per support (200,000 pounds gross) have been installed.

LOAD CELL ALIGNMENT

Cell alignment is unlikely to vary significantly in service since the tension flexure rods and spherical washers tend to accommodate local support deflections.

VESSEL NOT AT CONSTANT AMBIENT TEMPERATURE

Differential motion between the vessel and its support structure is accommodated by adjusting the length of the tension flexure rods. Additional accessories are not required; the small sideload error introduced by friction in the expansion assemblies is avoided.

LATERAL RESTRAINTS

May not be required for vented systems weighing nonhazardous dry products, free from structural vibration, since a hanging mass is inherently stable.

SENSITIVITY TO STRUCTURAL SUPPORT VIBRATION

Tends to be more sensitive because of the reduced structural stiffness and damping capability caused by the tension linkage and the likelihood of the vessel's having a small mass more readily set in motion.

OPEN SPACE REQUIREMENT

If the floor beneath the vessel must be open for traffic, tension mounting is an option to be considered.

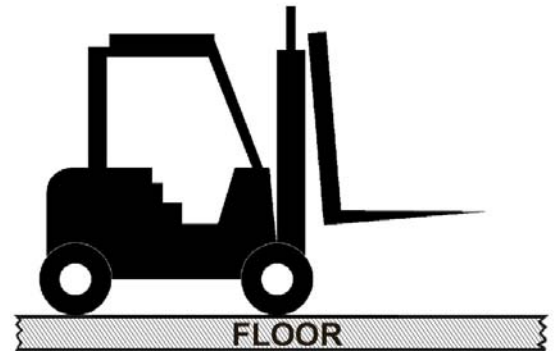
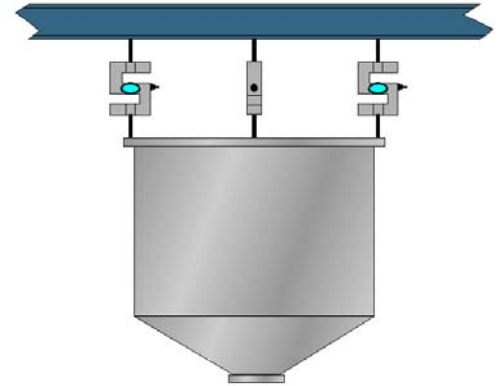

If the floor beneath the vessel must be open for traffic, tension mounting is an option to be considered.

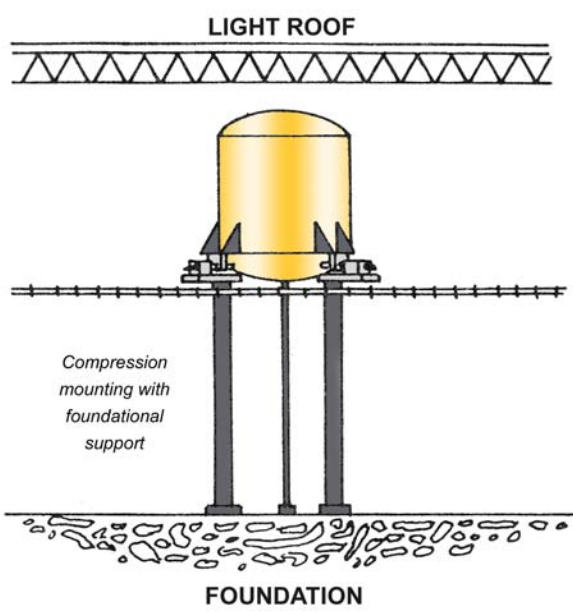

Vessel mounting - plant layout factors

GENERAL RECOMMENDATIONS

Always mount the vessel to the sturdiest structure available, i.e., foundation floor, heavy floor, floor above a “traffic floor”, or a sturdy roof. Vessels installed on a light roof, light floor, or a “traffic floor” may lose processing integrity due to structural shifting or extraneous vibration forces.

WEAK FLOOR OR NO FLOOR

When upgrading an older plant, where a convenient floor exists but is too weak to carry a new weigh vessel, or where there is no convenient structure, the weigh vessel may require a special installation as shown in the light roof illustration.

ACCESS FOR INSPECTION

When processes must be monitored via vessel view ports, arrangements must be made such that the observer does not load the vessel.

FLOOR VIBRATION OR DEFLECTION

Avoid mounting a vessel to a support structure subject to deflection or vibration from traffic or rotating equipment.

Always mount the vessel to the sturdiest structure available

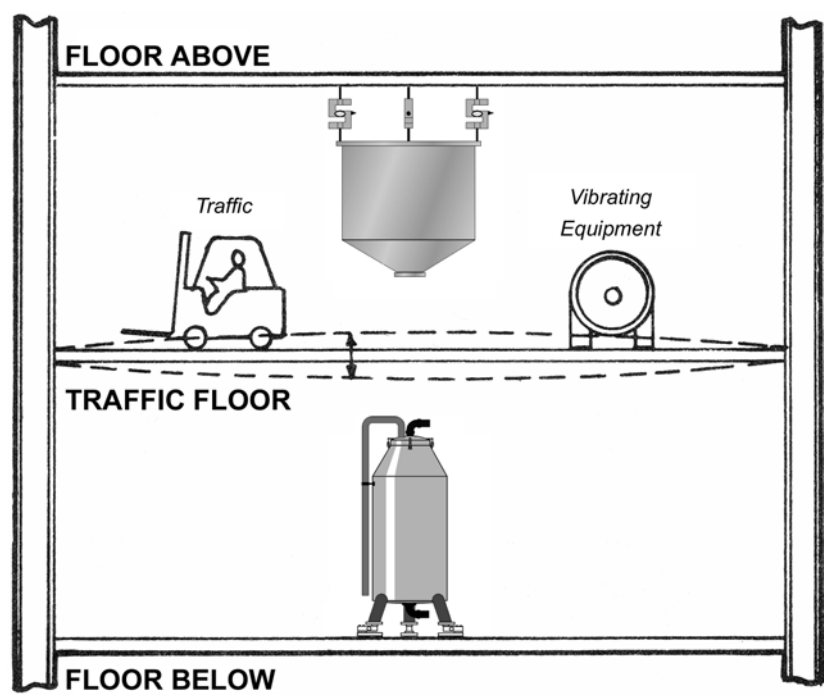
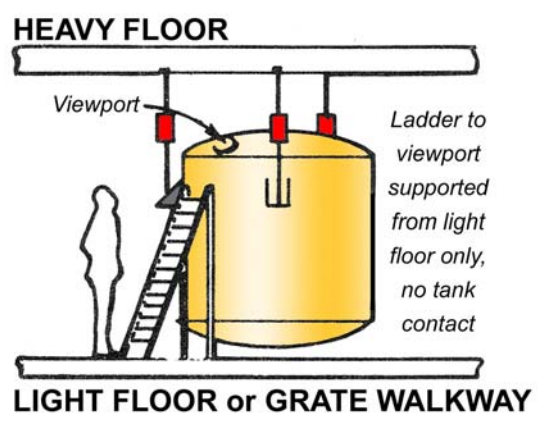

Vessel mounting - plant layout factors (continued)

LATERAL RESTRAINT INSTALLATION (Canister and S-Cells)
 If a weigh vessel requires some form of lateral restraints, consider which mounting configuration best accommodates the installation.

OUTDOOR LOCATION

Vessels situated outdoors are usually mounted in compression on a concrete slab to minimize construction costs and maximize vessel stability. When material is to be transferred directly from the vessels to trucks or railroad cars, the vessels are sometimes elevated by a steel frame on concrete piers.

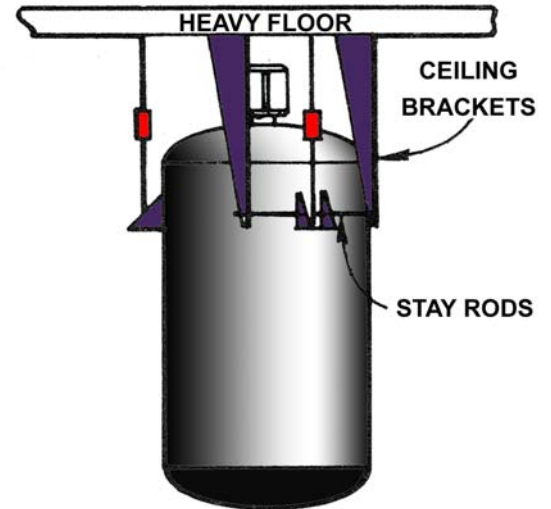
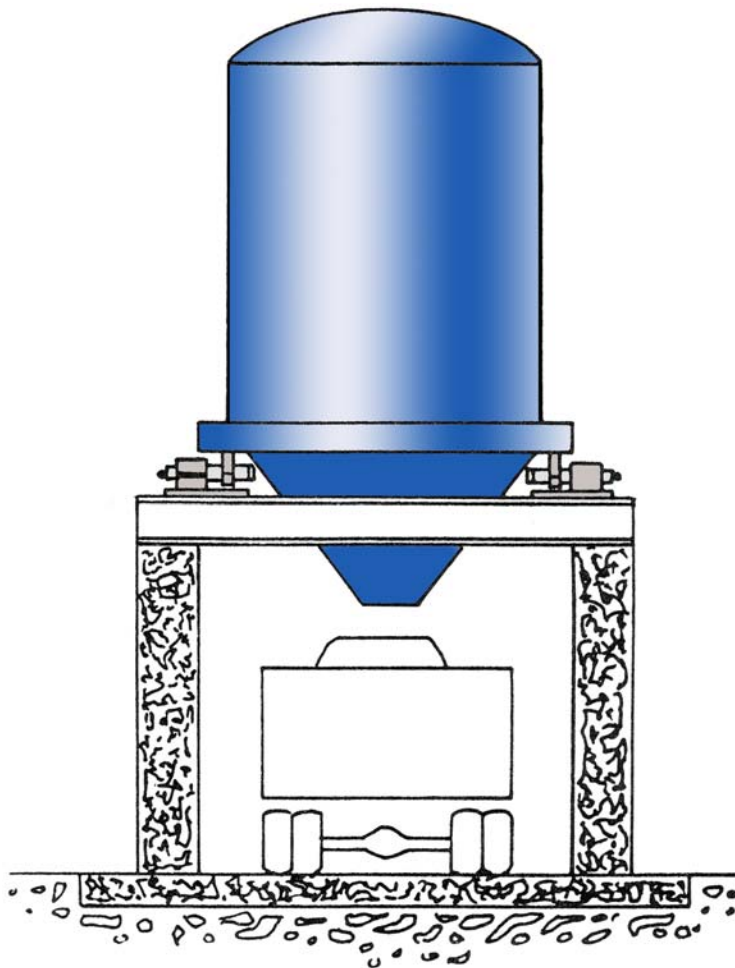

U3SB and canister load cell installations may require lateral restraining stay and/or check rods

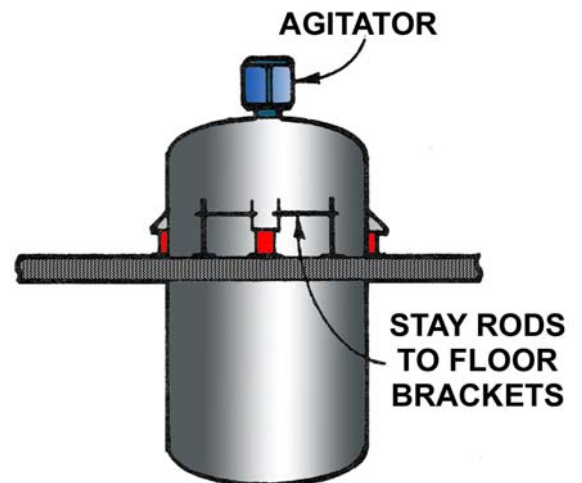

Vessel mounting - number of supports

This aspect of vessel design is fairly straightforward, as indicated by the following guidelines:

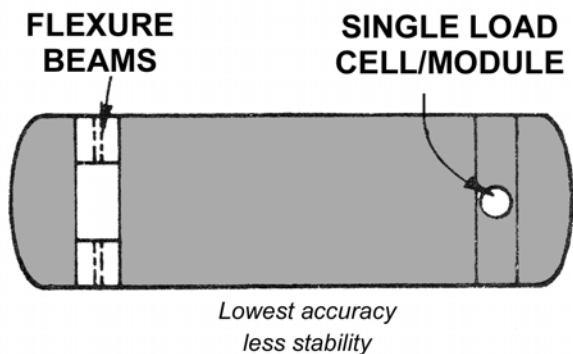
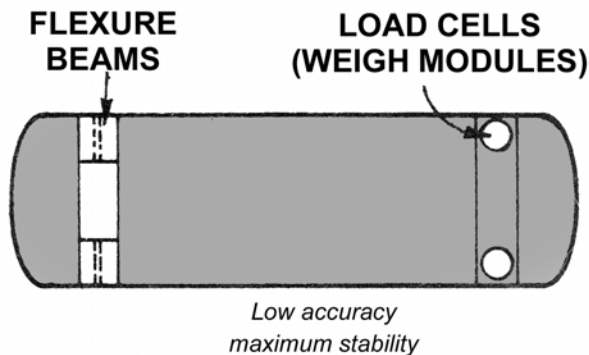
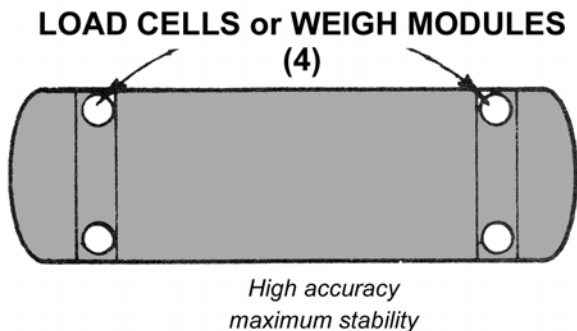

UPRIGHT CYLINDRICAL VESSELS (not shown) should have three support points. Load transducer installation is simplified since load distribution among the supports is automatic; gapping between the load transducer and vessel support due to local support structure deflection in response to traffic or vessel interaction is impossible for the same reason - three points determine a plane.

EXCEPTIONS arise when stability and cost effectiveness are major factors. Vessels requiring greater stability should have at least four supports; a round vessel with four supports (not shown) is 22% more stable against tipping than the same vessel with three supports. In this category are vessels exposed to high wind or seismic loads, violent internal chemical reactions, or massive fluid sloshing as a result of agitation.

Vessels of large capacity such as coal silos in excess of 1,000,000 pounds (not shown) cannot be supported economically on just a few supports since vessel wall thickness and reinforcement increases as the number of supports decreases. These vessels are usually designed with eight supports, the maximum recommended by Vishay BLH. (Load distribution among the load transducers becomes problematical with larger numbers of supports.)

Small vessels weighing up to 3,000 pounds may be suspended from a single cell in tension (not shown).

RECTANGULAR VESSELS (HOPPERS, BINS) generally have four supports, an accommodation to the vessel geometry, symmetry, and steel structural framework.

HORIZONTAL CYLINDRICAL VESSELS usually have two saddles positioned symmetrically a short distance in from the ends. Three or four supports are placed under the saddles, depending upon the stability and accuracy required.

Load cell (or weigh module) selection

LOAD CELL (MODULE) CAPACITY formerly was determined in the following manner:

- Estimate vessel “tare” weight, the weight of the empty vessel plus attached piping, agitators, vibrators, insulation, and vessel heating fluids, as appropriate.
- Determine the maximum weight of the vessel contents, or “live load”.
- Add the tare weight and live load to obtain the “gross vessel weight”.
- Divide the gross weight by the number of vessel supports and multiply by 1.25 to yield the minimum recommended load cell capacity;

$$Capacity = 1.25K \frac{Gross\ Vessel\ Weight}{Number\ of\ Supports}$$

where K = dynamic load factor = 1

Today, however, Vishay BLH sales representatives are equipped with electronic sizing software that precisely calculates the exact load cell capacity and profiles actual system performance. “Syscalc” software specifies load cell capacity, calculates complete error analysis, and precisely predicts functional system signal levels.

Contact your local sales representative, or Vishay BLH Field Service Engineering to have a free system profile established for every/any weigh vessel.

CONVERSION FORMULA

Since some load cells are specified in terms of ‘Newtons’, the following formula can be used to convert to pounds or kilograms.

$$1\ Newton = 0.225\ lbs = 0.102\ kgs$$

(approximate gravitational equivalent)

BLH SYSTEMCALculations		VERSION 4.04	8/8/2002
BLH DXP-15 and KDH-3-500 System Error Analysis			07-Mar-05
Enter Customer Name	----->	Steve Duke/Southern Fabrication Contr.	
Enter Project Reference	----->		
Enter Instrument Model Number	----->	DXP-15	
Enter Load Cell Model Number	----->	KDH-3-500	
Enter Number of Load Cells	----->	4	
Enter Vessel Dead Weight	----->	60,000	lb
Enter Vessel Live Weight	----->	200,000	lb
Enter Temperature Variation	----->	5	degrees F
Are the Load Cells in Division 1 (Yes/No)	----->	NO	
Load Cell Capacity		112,400	lb
System Capacity		449,600	lb
Gross Weight		260,000	lb
LOAD CELL(s) ERROR ANALYSIS			
Creep Error		0.05	%
Combined Error (Non-Linearity & Hysteresis)		0.10	%
Non-Repeatability Error		0.02	%
Zero Temperature Error		0.0125	%
Span Temperature Error		0.0075	%
SUM of the Errors SQUARED		0.013	%
MEAN of the Sum of Errors Squared		0.0026	%
ROOT Mean Square of the Errors (RMS)		0.0512	%
SYSTEM SIGNAL LEVELS			
Excitation Voltage		10.00	Vdc
Load Cell Rated Output		2	mV/V
Signal at System Capacity		20	mV
Dead Weight Signal		2.669	mV
Live Weight Signal		8.897	mV
SYSTEM CAPABILITY			
Instrument Digital Resolution		20.000	lb
Instrument Analog Resolution		50.000	lb
Maximum Probable Digital System Error		0.069%	77.560 lb
Maximum Probable Analog System Error		0.096%	107.560 lb
NOTE: Calculations represent system capability. Actual performance may be degraded by installation conditions. BLH Weigh System Handbook is available for guidance in achieving system capability.			

Sample “Syscalc” performance printout



High accuracy process weighing, weigh modules

Load cell (or weigh module) selection (continued)

LOAD CELL (WEIGH MODULE) TYPE

Vishay BLH manufactures many types of load cells and weigh modules to suit a variety of applications - general purpose, precision, high temperature, and rugged environment. General-purpose cells/modules are suitable for low accuracy systems; KIS Beams, with tighter accuracy specifications, are intended for high accuracy installations; high temperature load cells are for use at ambient temperature above 130°F and incorporate materials that function under continuous elevated temperature operations; ruggedized cells/modules are specially designed for mechanical abuse. Consult Vishay BLH for specific application recommendations.

LOAD CELL/MODULE TERMINATION

Vishay BLH typically supplies load cells/modules with 10 meters of integral cable. Other lengths or types of cables for special environments are available upon request.

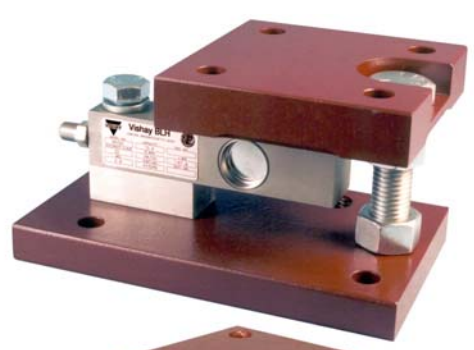

Lower accuracy, general purpose weigh modules

Load cell field calibration

COMPLETE INFORMATION regarding weigh system calibration is available in Vishay BLH's publication entitled *An Overview of Calibration Methods and Procedures for Process and Inventory Weigh Systems*. To obtain a copy, request publication number FSD 001.

VESSELS FULLY SUPPORTED ON LOAD CELLS - Calibration accuracies to errors no greater than $<0.25\%$ of full scale can be performed by electronic substitution using a Model 625 Precision Calibrator or equivalent. This method assumes the vessel to be free of significant mechanical restrictions; i.e., all attached piping can be felt to move under a sharp blow of the fist; no structural hang-ups will occur when the vessel is fully loaded. Barring any mechanical problems or unusually difficult vessel access, electronic calibration takes just a few hours. Note that load cell cables should not be shortened when electronic calibration is used.

Calibration accuracies to $<0.25\%$ of full scale is usually performed with dead weights, the only method recognized by Weights and Measures Agencies. Refer to the section on Special Installation Procedures for a discussion of the techniques available. Systems in which maximum accuracy must be achieved should be at their uniform operating temperature when calibration is performed. Vishay

VESSELS PARTIALLY SUPPORTED ON LOAD CELLS - If the main concern is repeatability, field calibration is unnecessary. If the weigh system accuracy must be known, then calibration by the material transfer method is required. (Dead weight calibration cannot be employed since the exact vessel center where weights would be applied is rarely precisely known or constant; i.e., a slight change in slope of the vessel causes liquid contents to accumulate toward the lower (downhill) regions, shifting the CG and, consequently, the load fraction seen by the transducers.)

An Overview Of Calibration Methods and Procedures for Process and Inventory Weigh Systems.

Allen Bradley Automation Fair - St. Louis, MO - 11/30/94 & 12/1/94
Presented by Ron Burke - BLH Electronics

Electronic weigh systems are often used in the process industries because they offer a non-intrusive, highly accurate and reliable measurement of mass within a process vessel or inventory silo. Properly installed and calibrated systems routinely achieve accuracies of 0.02% with a measurement precision, or resolution, of one part in 50,000. These performance specifications compare very favorably against the best level (0.5%) and low measurement (0.1%) technologies.

The changing industrial climate is placing increasingly greater emphasis on quality of product. Many of the most progressive manufacturers are pursuing official recognition of quality systems through ISO 9000 registration and the implementation of total quality programs within their enterprises.

These changes are resulting in a greater awareness of "weight" as a preferred process variable and the importance of properly installing, servicing and calibrating electronic weighing systems. It is now becoming more and more important to not only accurately and properly calibrate, but to also document the calibration.

There are several ways to calibrate an electronic weigh system that range from a simple electronic simulation to a multi-point applied deadweight calibration. The proper method to use is largely a function of the required accuracy, traceability and perhaps most importantly, the method that is most practical, given time, budgets, and physical configuration of the system.

For example, calibration of a freestanding inventory silo containing a low cost material can be cost effectively calibrated using an electronic simulation method. However at the other extreme, a pharmaceutical process reactor with connected piping and subjected to validation review by the FDA may need to be calibrated using deadweights to full scale capacity.

The range of calibration options available, where and how to apply them, the expected results and case histories of actual results will be discussed. Where appropriate, structural issues and system specifications will be addressed. Finally, a chart will be developed that summarizes the methods, results and applicability.

System descriptions
A traditional system uses several load cells to fully support the vessel or structure being measured. The analog mV signal from each of the transducers is connected in parallel within a summing circuit that provides a single mV signal output corresponding to the average of the multiple load cell signals. This averaged signal is usually connected to the input of a weight transmitter/indicator device where it is conditioned, digitized, scaled and displayed and/or re-transmitted. (Figure 1)

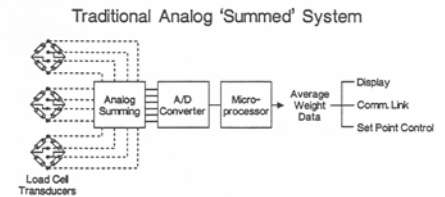

Figure 1
Page 1 FSD 001 Ver 2.0 February 1995

Request Vishay BLH
publication An
Overview of
Calibration Methods
and Procedures for
Process and Inventory
Weigh Systems

Weigh modules combine load cells (typically beams) and mounting hardware to form self-contained and self-restrained weight measurement units. Choosing load cell based weigh modules immediately resolves the problem of vessel restraint for most applications. Properly designed weigh module based systems rarely require extraneous check and stay rods. However, care must be given to the installation location. Module selection should be based upon local seismic, weather, and building code specifications. Weigh module structural evaluation and nomograph data should be consulted when designing weigh systems in “high risk” wind load or seismic regions.

Integral weigh module mounting hardware typically consists of a top plate or mounting yoke which attaches to the vessel and a bottom plate for ground/base mounting. In a properly constructed module, load cells are uniquely mounted such that the weigh vessel and the beam are united as one entity without undue friction or binding.

Unique KIS Beam weigh modules employ a retainer yoke, which attaches directly to the vessel support bracket and completely encircles the beam itself. Since a retainer yoke encircles each beam, it is impossible for the tank (vessel) to tip over. Should excessive side loading force be applied to the vessel causing an upturning moment, the vessel can only rise a fraction of an inch until the lower block of the retainer yoke contacts the underside of the beam. Only under extreme conditions, such as heavy winds on a tall storage silo, would it be necessary to consider installing safety check rods. Vessels mounted on KIS beams typically do not require stay rods. In rare situations where excessive seismic disturbance, agitation, thermal expansion, or vibration could potentially cause slippage of the retainer yoke on the beam surface, optional safety stop rings prevent the weigh vessel from sliding off the beam.

Weigh Module accessory options

DUMMY BEAMS are used in place of “live” beams during mechanical installation procedures. Dummy beams are solid steel shafts with the same dimensions as the corresponding weigh module beam/cell. Using dummy beams during system installation prevents damage from stray welding currents and/or mechanical impact.

THERMAL INSULATION PADS reduce heat conducted from a heated vessel thereby maintaining cell/beam signal integrity. The pads are made of rigid laminate with extremely low thermal conductivity, Vishay BLH recommends using insulation pads if the vessel mounting surface temperature exceeds 52C (130F). Pads are one inch thick with bolt spacing identical to module top plates.

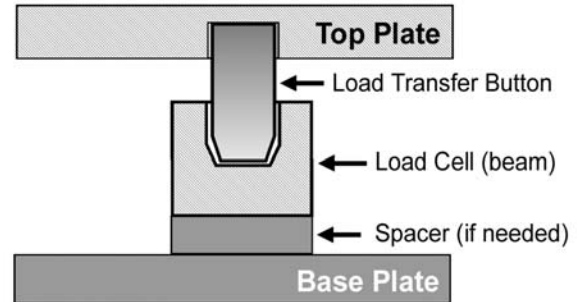

Typical Load Cell Weigh Module Construction

Weigh modules combine load cells (typically beams) and mounting hardware to form self-contained and self-restrained weight measurement units

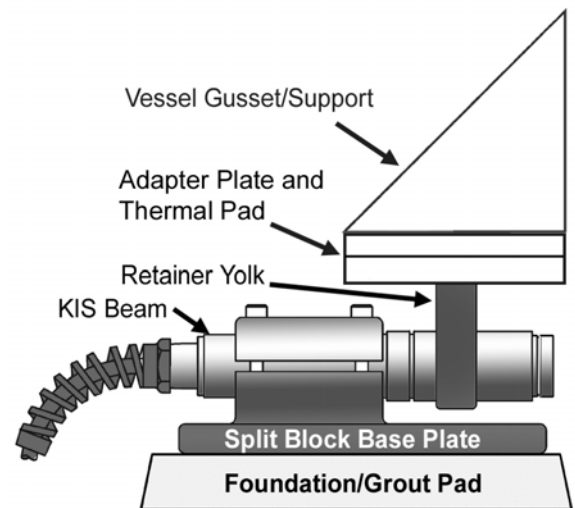

Unique KIS weigh modules for process weighing applications

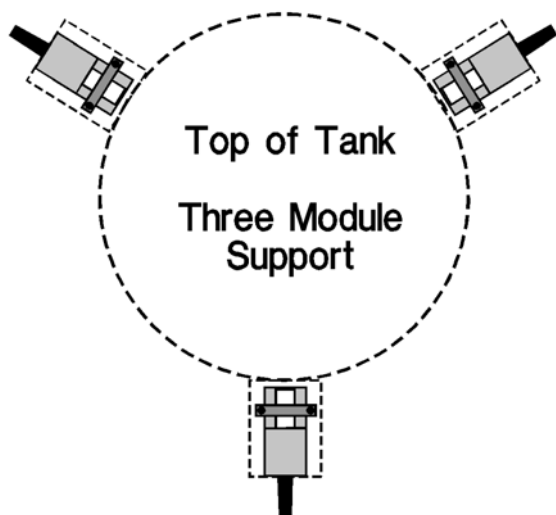

Weigh module mounting footprint

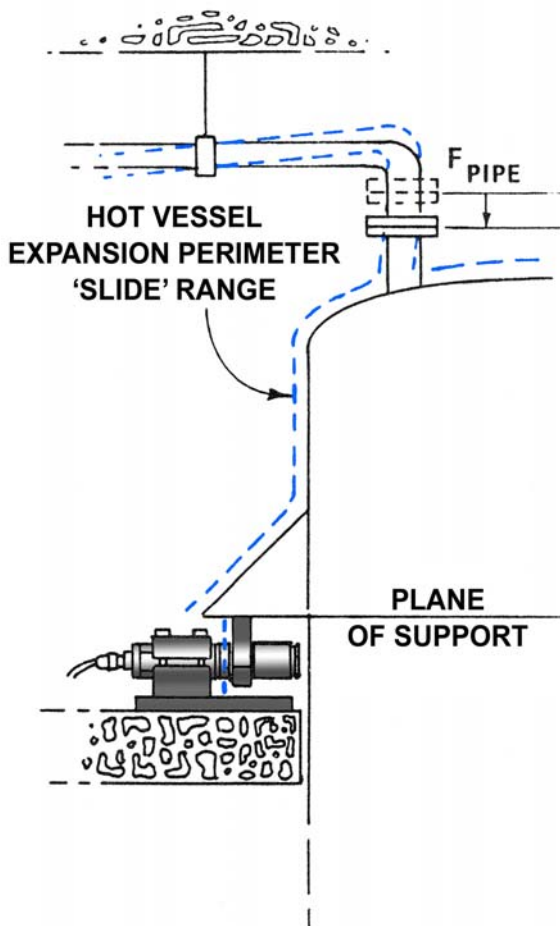

Heated vessel thermal expansion and contraction

Weigh module installation procedures

Preferred method - dummy beam substitution

To avoid damaging module beams/cells, Vishay BLH recommends that mechanical installation procedures be performed with dummy beam replacements.

Locate module positions based upon the actual vessel “footprint”. The vessel “footprint” is determined by engineering design drawings or temporarily positioning the vessel in its final installed location. Make certain that all bolt holes for the base and top plates (or yokes) align correctly.

Install dummy beams in the mounting base housings. Locate modules, with dummy beam installed, at each footprint mounting location. Level each module to within $\frac{1}{2}^\circ$ (shim base plates as necessary, see following page for details) and lower the vessel onto the modules. Alternately, modules with dummy beams can be attached to the vessel supports and then lowered onto the mounting base foundation locations. Level and shim procedures must still be performed. It is recommended that a Vishay BLH Field Service Engineer supervise this process.

Using a hydraulic jack, lift the vessel at each support bracket, and, replace each dummy beam with a ‘live’ beam or cell, one at a time.

Release the jack and lower the vessel support gently to avoid ‘shock’ damage to the ‘live’ beam. Repeat substitution procedures at each vessel support bracket.

Securely fasten all top and base plate bolts to manufacturer recommended torque specifications.

Thermal expansion considerations

When application conditions suggest that vessel expansion or contraction, due to thermal forces, will be a standard feature of the overall process, special attention must be paid to weigh module selection. Module design must incorporate a top plate or yoke flexible enough to ‘slide’ with thermal expansion and contraction, yet not introduce extraneous force readings to the output signal. Also, modules must allow enough ‘slide’ leeway so as not to bind or restrict the vessel during periods of expansion and contraction.

With a double cantilevered, cylindrical beam design, Vishay BLH KIS modules are the perfect choice for these applications. Slight yoke displacement from the recommended beam load point will not greatly affect the system accuracy or repeatability, as each millimeter of displacement yields only a 0.005% change in calibration.

As product quality, inventory management, plant integration, and delivery schedules emerge as vital operating issues; electronic weighing becomes an indispensable engineering asset.

Product quality

In years past, it was acceptable practice for the plant ‘resident expert’ to manually add a shovel full of this or a beaker full of that to bring the batch within tolerance limits. Obviously, times have changed. With today’s tighter quality specifications and production schedules, batch processing must be precise, repeatable, and redundant, with or without the ‘resident expert’.

For the present manufacturing environment, electronic weighing offers the following advantages:

- **Load cells are non-intrusive - the system remains closed throughout the process eliminating the possibility of external contamination.**
- **Load cell/module based systems provide the best accuracy and repeatability (0.01%)**
- **Load cell/module systems are virtually maintenance free once installed**
- **Weight based system diagnostics monitor the entire batch process for impending equipment failures or dynamic, out-of-tolerance changes**

Note that older load cell equipment/systems may not meet all of the criteria listed above. For quality critical batch process systems, please review the upgrade indicators below:

- **Recurrent system downtime where load cells or load cell indicator is suspect**
- **Product inconsistency from batch to batch**
- **Unexplained spikes, surges, or drift periods encountered**
- **Performance or quality tolerance specifications increase based upon customer demand**

Systems experiencing any of the above symptoms should be considered for a technology upgrade. In some cases, only the system instrumentation need be upgraded to gain the latest Safe-Weigh® features and benefits.



It used to be acceptable practice for the plant ‘resident expert’ to manually add a shovel full of this or a beaker full of that to bring the batch within tolerance limits



Vishay BLH LCP-104 Safe-Weigh® Systems measure each system cell or module independently to ensure maximum accuracy and repeatability

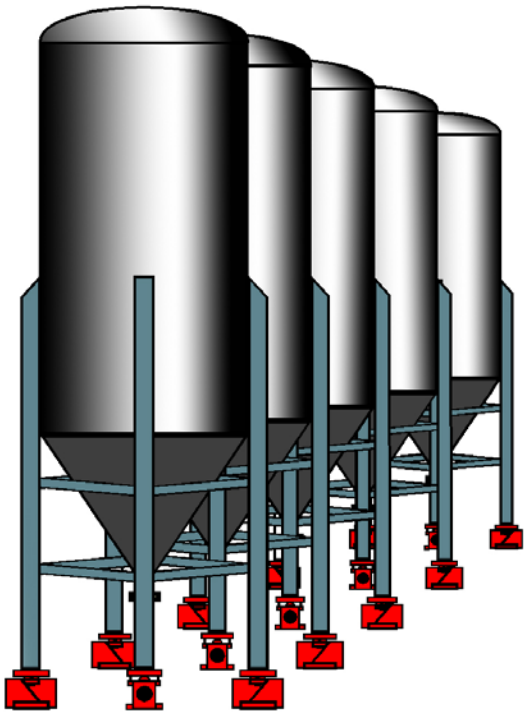

Ingredient silos converted to weighing systems facilitate inventory management

Inventory management

Converting static storage bins, tanks, silos, and hoppers to simple weight or level measurement systems easily monitors ingredient availability and usage patterns. Inventory systems typically do not require the precision specifications of high end batching systems and, therefore, can be implemented quite inexpensively. Economical load cells/modules and low cost indicators provide enough accuracy to track ingredient usage and alert administrative personnel to reorder/refill needs.

In some applications, where vessel contents are self-leveling (liquids, light slurries, etc.), 'live' load cells/modules are not needed at each support. Partial support systems often provide adequate system accuracy at a substantially lower cost.

Please note, however, that these less expensive components and systems must be installed carefully to function properly. Follow all the installation tips and procedures presented in this handbook to obtain optimal performance from every weighing system.

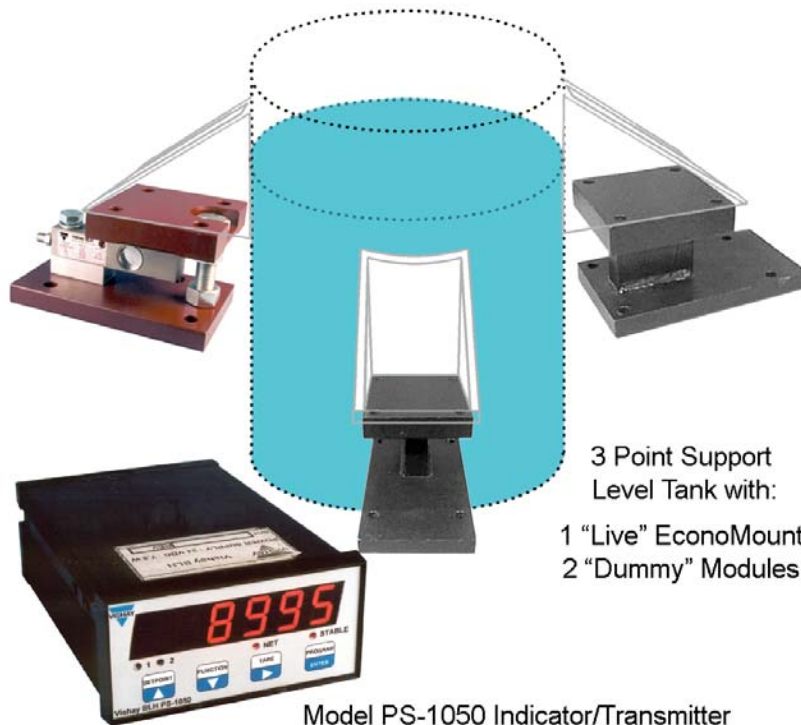

3 Point Support
Level Tank with:
1 "Live" EconoMount
2 "Dummy" Modules

Model PS-1050 Indicator/Transmitter

Simple level system with single weigh module support

Redundant technology

Installing load cell systems on systems with other measurement technology ensures constant manufacturing throughput while double-checking quality standards. Many manufacturers using other forms of measurement technology, such as flow meters, install load cell systems as a redundant or alternate process option.

With extremely high accuracy specifications and low maintenance requirements, load cells are the perfect choice for backup or double-check systems. Should the primary measurement system fail, processing continues automatically and accurately via load cell measurement.

With extremely high accuracy specifications and low maintenance requirements, load cells are the perfect choice for backup or double-check systems

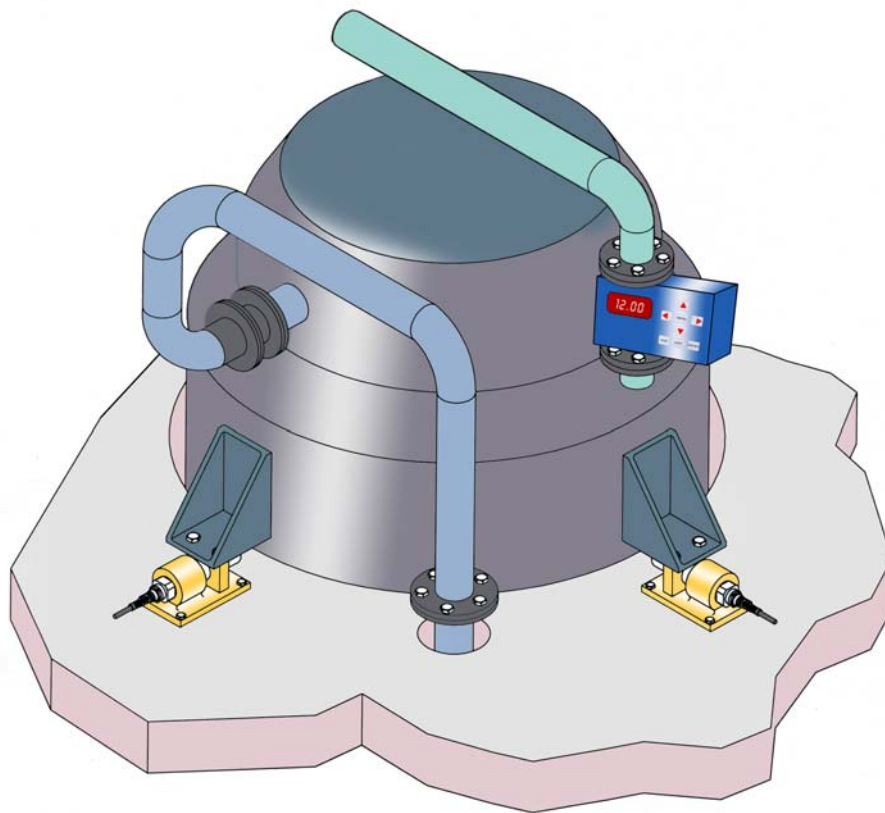

Flowmeter based measurement system with redundant weigh module backup

Sigma Delta A-D conversion technology makes it possible for a single weigh system instrument to measure each load cell/module individually. The true benefit of measuring each cell independently is not merely precision weight data; it's gaining a real-time picture of system performance throughout repetitive batch cycles. Monitoring each cell, rather than a summed equivalent of all cells, significantly enhances system diagnostic capabilities. Enhanced diagnostic surveillance minimizes system failure rates and production downtime.

When multiple cells are summed (averaged) with a conventional summing junction box, the total weight picture provides a certain degree of accuracy and functionality. Diagnostic evaluation, however, is limited to simple overload and motion detection. Individual load cell/module and system structural problems go unnoticed until a major failure occurs. For example:

- **What if a single cell is being overloaded during each successive batch cycle? If another cell (or multiple cells) is “under loaded” this condition will never be “noticed” by a summing junction box.**
- **What if a residual “heel” is building up slowly on one side of the vessel? A summed system may catch this condition once auto zero parameters are exceeded, but it will take much valuable time.**
- **What if a piping restraint breaks loose and additional dead weight is added to the total system gross weight?**
- **What if a vessel structural support starts to buckle?**
- **What if a single cell, contaminated by moisture leakage or structurally damaged by repeated shock loading, begins to drift out of tolerance? Batch integrity and product quality may be compromised.**

Analog summing probably won't catch these “what-if” conditions in time to head off serious system malfunctions.

Measuring each cell independently introduces a whole new level of trend analysis and error detection capability. It's like adding a crystal ball to the process. Unique diagnostic “look-ahead profiling” alerts operating personnel to potential system malfunctions before they happen. Load shift, signal drift, and individual cell overload analysis algorithms; performed dynamically throughout the batch cycle, spot minor system digressions before they become production disruptive failures.



Measuring each load cell or weigh module independently, is like adding a crystal ball to the process

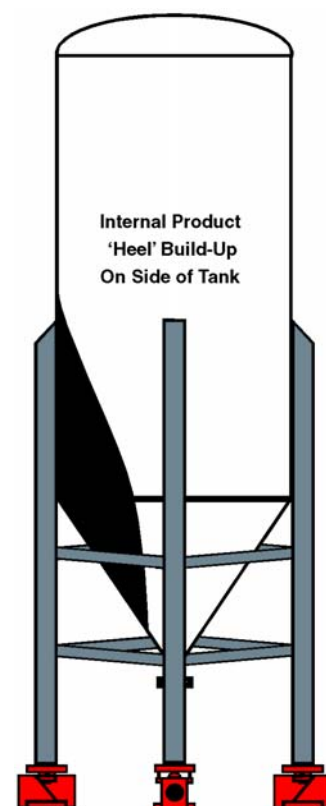

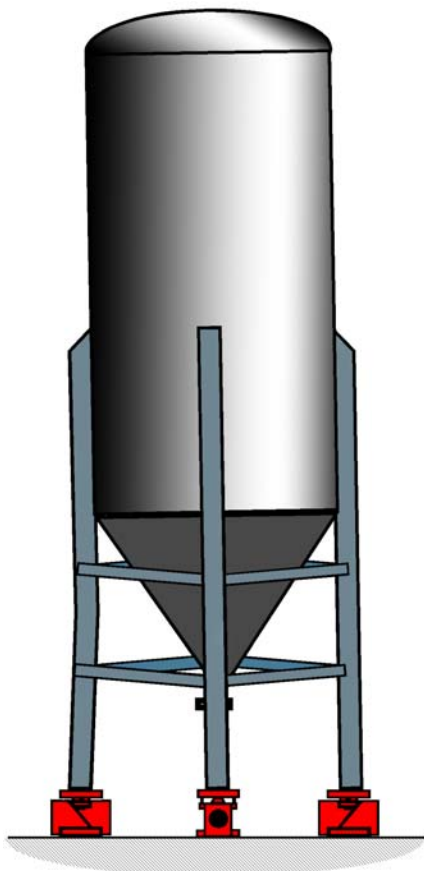

Inferior support structure buckles under full tank load

SHIFT TEST

Load shift testing detects significant load changes in an operational weigh system. An excessive load shift value indicates that system equipment or vessel contents have shifted so as to place a disproportional amount of weight on a single cell. Load shifts can be caused by many things, among a few are: heel build up and product bridging on one side of a tank, support structure changes introducing more force from connected pipes or process equipment, excessive deflection of a support leg, or faulty signal from the load cell.

Advanced design process instrumentation, such as Vishay BLH DXp and LCp-104 Safe-Weigh® Systems, should be capable showing the percent of shift value for each individual cell.

DRIFT TEST

Drift testing detects a load cell output that is changing beyond acceptable tolerance levels. When the system stabilizes, after a period of weight activity, the process instrument waits momentarily and then stores a reference value for each cell. Successive values are compared to stored values and checked for compliance with a preset drift tolerance selection. Drift testing typically is abandoned when the system is active.

Long-term load cell drift problems may be caused by electrical leakage or system structural problems. Since most systems usually experience inactive periods of 8 or more hours, this test is highly effective at catching long-term drift problems. Long term drift testing provides 'early warning detection' for cells that may fail completely at a later date.

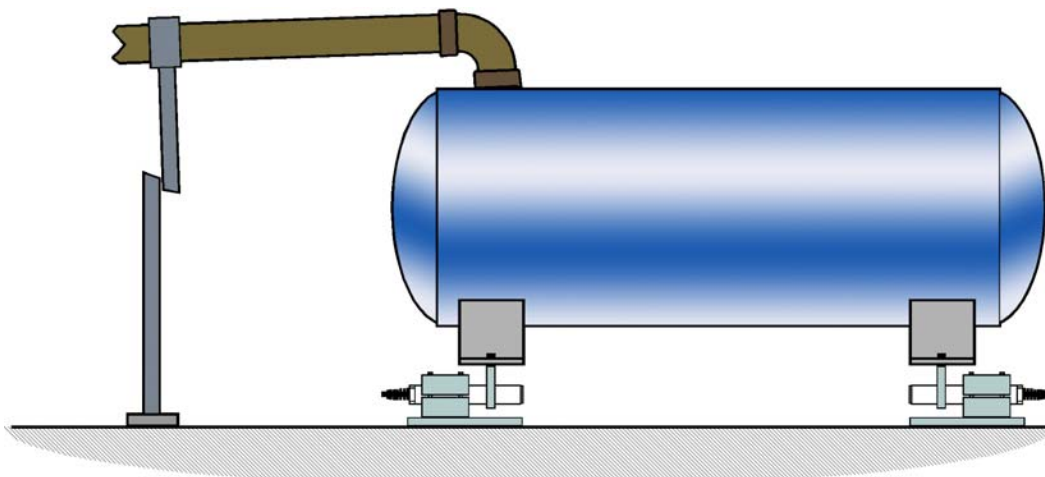

A broken pipe restraint places the full load of system piping on the vessel

OVERLOAD TEST

Since overload is critical to system safety and load cell integrity, it must be checked constantly. Cell overload limits are typically set at the cell's rated capacity. A running peak value for each cell should be recorded and may be checked (or cleared) at any time. In older weigh systems, overload typically signaled a total system overload (system capacity exceeded).

Independent cell diagnostics, however, can alert an operator to a single cell overload, even though total weight does not exceed system capacity. Single cell overloads usually are caused by heel buildup, shock loads (mixers/blenders, ingredient free fall force, etc.) and poor system design.

Independent cell diagnostics can alert an operator to a single cell overload, even though total weight does not exceed system capacity

DEGRADE MODE FUNCTION

If a diagnostic test identifies one or more load cells in the system as providing faulty data, instruments such as Vishay BLH's DXp-40 or LCp-104, provide a temporary "degrade mode" operation alternative. Degrade mode operation eliminates erroneous data from the suspect cell(s). Since DXp-40 and LCp-104 instruments measure each channel independently and digitally sum the weight information, degraded mode shuts off the erroneous measurement from the suspect cell(s) and inserts a calculated digital substitute value, corrected for system balance and channel sensitivity. The resulting system performance will be reduced somewhat, but still compensated for load imbalance. Degrade mode makes it possible to continue weigh system operation without interruption until the faulty cell(s) is replaced.

NOTE: Degrade mode is most effective when the vessel contents are self-leveling.

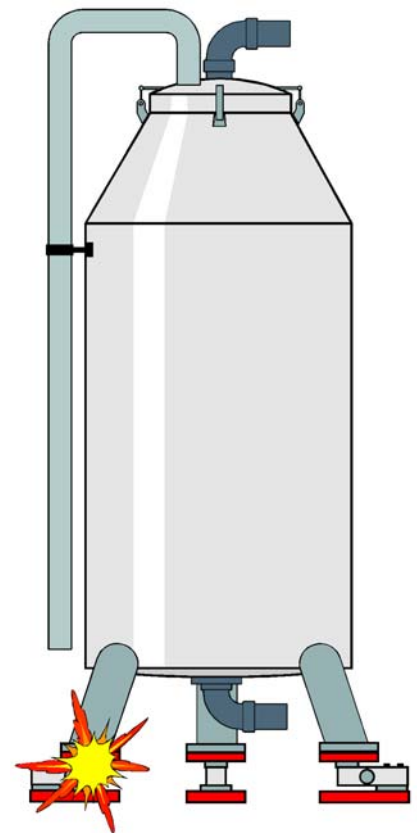

Degrade mode makes it possible to continue weigh system operation without interruption until the faulty cell is replaced

Influence of vessel piping and support deflection

Weigh system problems sometimes arise after a system has been put into operation. The principal cause of these problems is mechanical restrictions to, and interaction with, the weigh vessel. The cause is invariably excessive vessel or support deflections, which may have been identified, but assumed to be insignificant, during the design phase, or were so obscure that they went undetected. In an effort to ensure that weigh systems function properly in all situations and environments, Vishay now presents some of the common and uncommon deflection problems that system designers encounter.

Vessel support bracket

Problem As live load increases, so does the deflection of the vessel wall under the support bracket, causing the bracket to tilt. This generates "sideloading" of the load cell by horizontal force components that are now present. Measurable readout error will result if tilt angle exceeds $\frac{1}{2}^\circ$; potentially significant error will result if the angle exceeds 1° . Further, if load cell is mounted on the bracket, a 'cosine error' occurs as a function of load cell inclination from initial plumb position.

Symptom Weigh system output is increasingly nonlinear with load.

Remedy Strengthen the vessel wall. If necessary, contact the vessel manufacturer for redesign and addition of appropriate stiffeners.

Vessel thermal growth

Problem Vessel expands as it comes up to operating temperature and generates vertical piping restrictions that vary with vessel, pipe, and structure temperature. Vessel expansion is also restricted when rigid electrical conduit used for load cell cable is anchored to support structure, or when small unrelated piping is attached to the weigh vessel to carry it between floors.

Symptom Weigh system readout registers a baseline shift. If vessel operates at several temperatures, a different baseline will occur for each. If weighing is performed while vessel is changing temperature, error is unavoidable.

Remedy Specify flexible piping attachments with adequate deflection capability for vessel growth at low force levels. Specify flexible conduit between vessel and structure. NEVER ATTACH miscellaneous piping, electrical conduit, etc., to the weigh vessel for support.

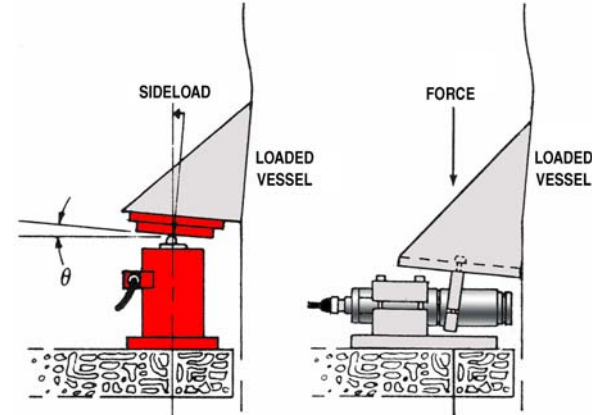

Loaded vessel - wall deflection

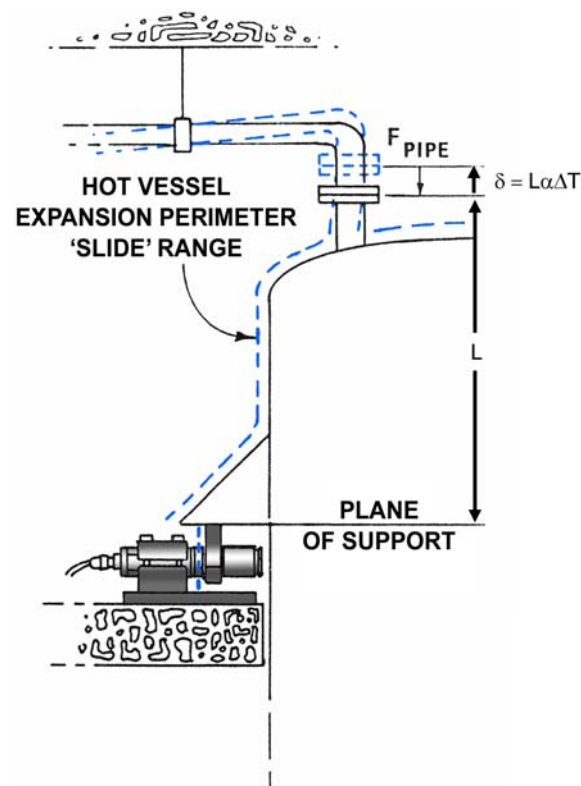

Vessel restriction due to thermal expansion

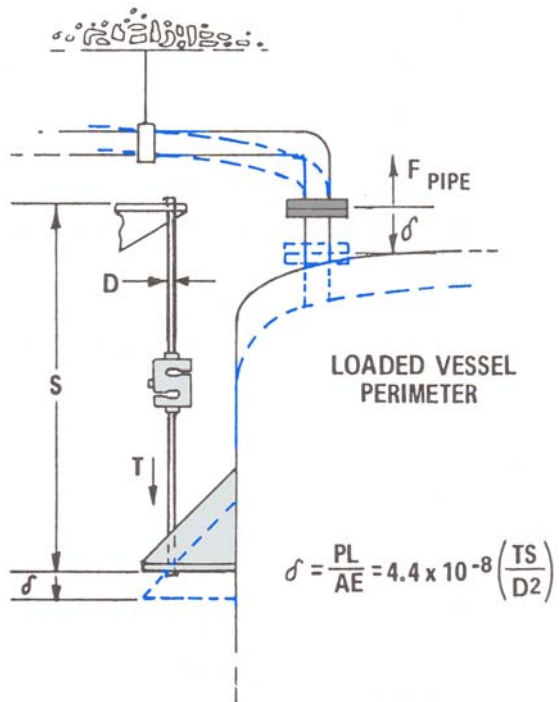

Tension linkage problems are resolved in two ways; keep linkage elongation, δ within $1/32$ '' under the maximum vessel live load and specify flexible piping attachments.

Tension linkage

- Problem** Tension flexure rod linkage elongates with load. Vessel thus sinks with load, developing vertical forces in attached piping. (This is a rare problem, only arising when linkage(s) go over 100 inches in the higher capacities.)
- Symptom** Weigh system output becomes increasingly nonlinear with load.
- Remedy** Keep linkage elongation, δ within $1/32$ '' under the maximum vessel live load. Specify flexible piping attachments.

Vessel support structure

- Problem** Large differential motion occurs between vessel support structure and structure support points of attached piping or stay rods. This is another common oversight made by structural and piping designers who assume the vessel to be stationary in space when in fact the support deflects with live load.

- Symptom** Weigh system output may be excessively nonlinear as large vessel displacement causes mechanical restrictions to develop; e.g., attached piping and lateral restraints draw tight and generate vertical forces, or piping installed just clearing adjacent structure now contacts it at increased loads.

- Remedy** Follow structural guidance provided in Structural Design section. Make piping attachments flexible. Install weigh modules rather than canister type load cells to eliminate lateral restraints. Support attached piping from structure supporting the vessel.

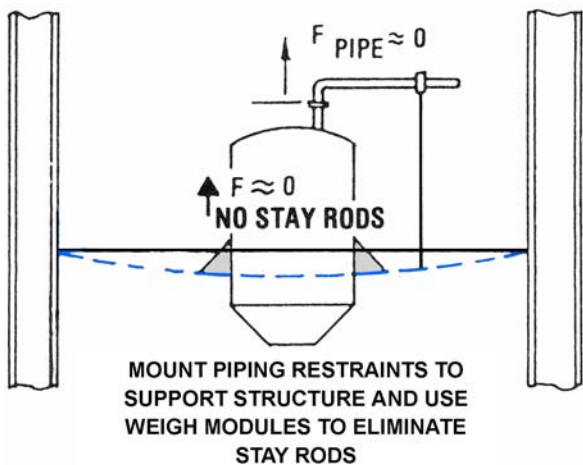

- Problem** All supports, whether exposed beams or concrete floors, deflect with load. A beam, however, will also twist if load is not applied through its shear center. This problem is generally more serious for compression systems than tension systems.

- Symptom** Nonlinearities will be displayed in weigh system output as beam deflections give rise to unpredictable load cell alignments. These, in turn, incur variable cosine errors and sideload forces in compression installations and cause high bending moments in ends of tension flexure rods.

- Remedy** Add more support to minimize deflection. Align load transducers with shear center of support beam; preferably, only symmetric 'I' or 'WF' -beams will be used whose shear center lies on an axis of symmetry. Refer to 'Structural Design' section for additional details.

Support structure problems are resolved in three ways; use weigh modules that don't require stay or check rods, align modules at the shear center of the structure, attach piping restraints to the deflecting structure

Vessel support structure (cont.)

Problem Vessel natural frequency, f , decreases with increasing structural deflection, δ , according to the formula,

$$f = \frac{1}{2p} \cdot \sqrt{\frac{g}{d}}$$

where 'g' equals the force of gravity (9.81 m/s² or 386 in./S²). If large support deflection occurs, the vessel may oscillate in response to nearby traffic (train, truck, forklift, crane, or just people), process equipment (pumps, agitators, diesel engines, cyclone devices, etc.), internal events (fluid sloshing, chemical reactions), or wind. Structural fatigue must now be a consideration as well. Good design practice avoids natural frequencies below 4 Hz in general, 8 Hz if a compressor is in the system.

For small oscillations, indicator/instrument digital filtering is recommended

Symptom Weigh system output oscillates, either randomly or periodically, to one or many amplitudes.

Remedy For small oscillations, dynamic digital filtering is available with most instrumentation. Additional filtering is possible for large oscillations by addition of large values of capacitance across load cell output.

Stiffen support structure, curtail or isolate as much of causative activity as possible, or schedule weigh vessel operation for low activity periods.

When high frequency forces are present, consider isolating the vibration source from the structure. The use of vibration mounts under the weigh vessel is not recommended since this will increase deflection and lower the natural frequency. Further, the added displacement may require reworking of external restraints and attached piping.

NOTE: Use the gross vessel weight support deflection table on the next page for reference.

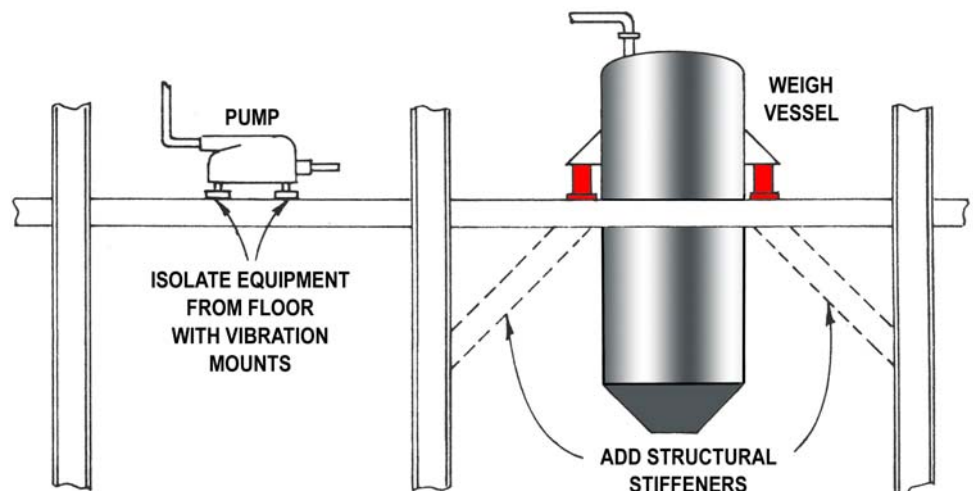

When high frequency forces are present, isolate the vibration source from the structure

Vessel support structure (cont.)

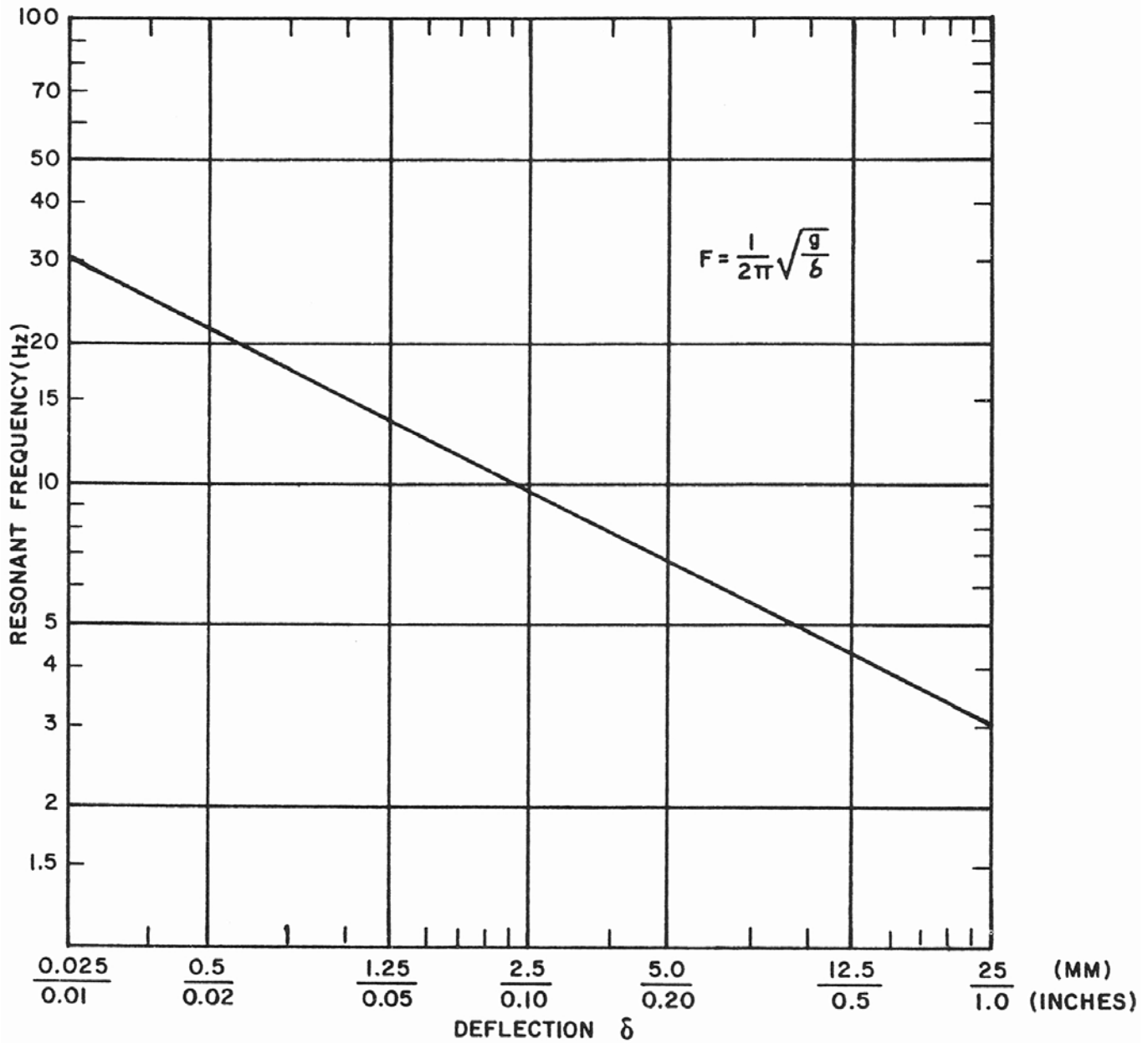

Gross vessel weight support deflection

Piping thermal growth

Problem Piping expands from fixed support to vessel attachment as hot fluid passes through. If pipe has a vertical leg between support and vessel, a vertical force may be imparted to vessel; if pipe has a major horizontal run, it may generate enough over-turning force to tilt a small weigh vessel, possibly even lifting a vessel bracket off of the load transducer.

Symptom Weigh system zero shifts as pipe discharges hot contents then cools to ambient again.

Remedy Attach fixed pipe support adjacent to vessel so only insignificant pipe expansion will be imposed upon weigh vessel. Specify flexible piping attachments or provide expansion loops in pipe between support and vessel.

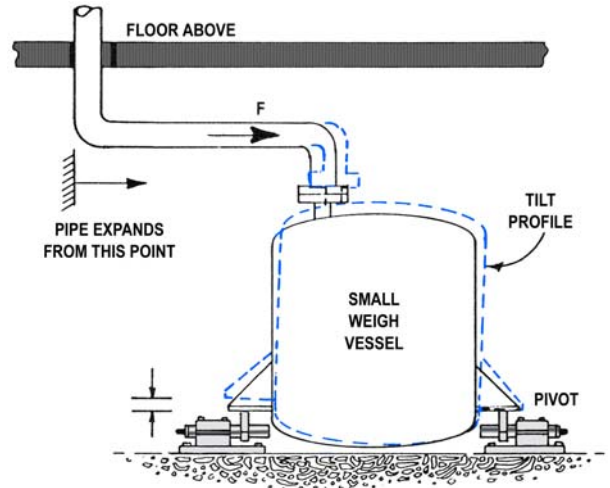

Piping expands from fixed support to vessel attachment as hot fluid passes through.

Piping support deflection

Problem Pipe supports, especially the first supports away from vessel, deflect under random influences, generating vertical pipe forces on weigh vessel. This is, perhaps, the most common problem encountered in the field.

Symptom Weigh system zero shifts randomly.

Remedy Attach first pipe to same structure weigh vessel rests upon. Specify flexible pipe attachments.

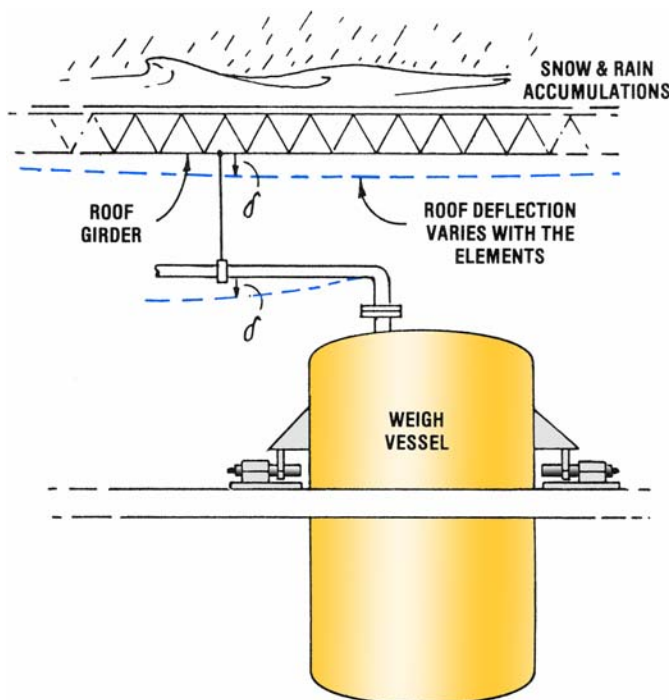

Pipe supports, especially the first supports away from vessel, deflect under random influences, generating vertical pipe forces on weigh vessel.

Piping support deflection due to vessel interaction

Problem Weigh vessel support structure loses initial level and tilts as a function of another vessel on same floor. While angle of weigh vessel may be small, net displacement at point of pipe attachments may be large, introducing multiple pipe forces. Further, if weigh vessel is only partially supported on load transducers, floor tilt may upset load fraction seen by load transducers if transducer alignment is not toward other vessel.

Symptom Weigh system output inexplicably shifts even though weigh vessel contents are known to be constant.

Remedy Specify flexible piping attachments. Support pipe from same floor weigh vessel rests upon. Convert partially supported weigh vessel so that it is fully supported by load transducers and floor tilt is less important. A less effective fix is to reposition the existing load transducers to line up toward the chief source of floor deflection and then observe center-of-gravity shift, at least partially.

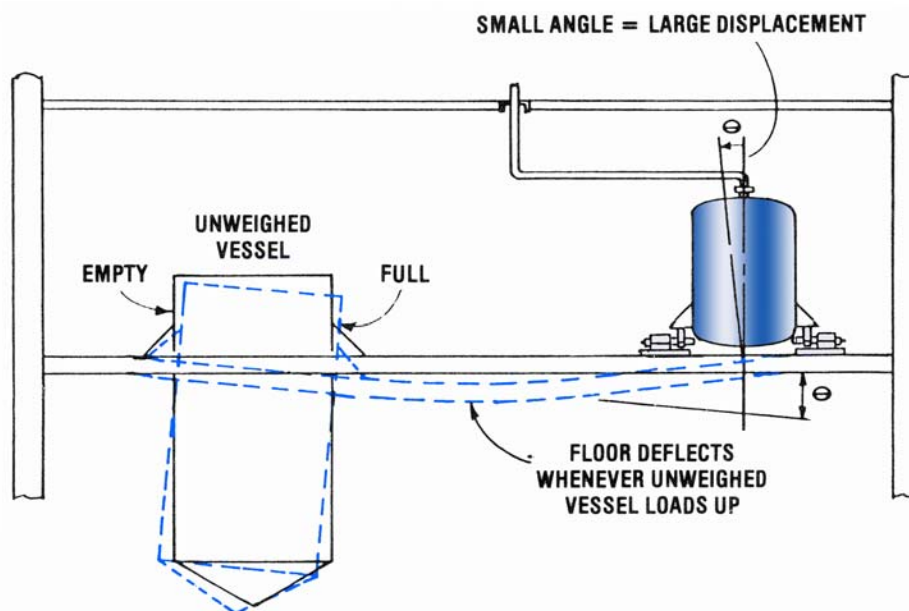

Incorrect piping arrangement for floor deflection. Support pipe from same floor weigh vessel rests upon

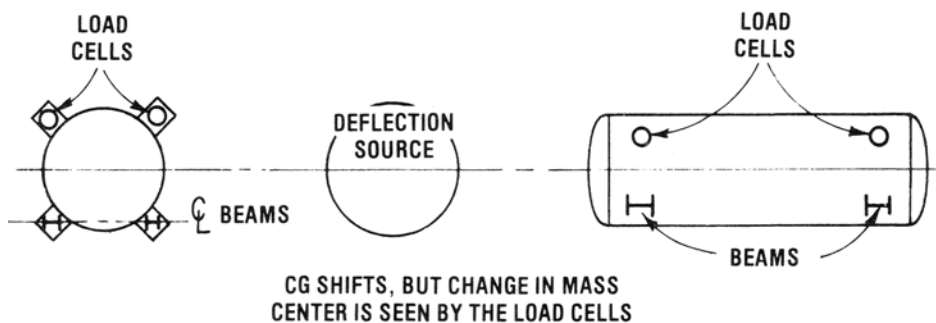

Correct mounting arrangement for partially supported vessels experiencing deflection duress

Piping support deflection due to vessel interaction

Problem Weigh vessels aligned in a row are supported such that adjacent vessels each have a load transducer resting on a common support beam. If one vessel is then heavily loaded while adjacent vessel remains lightly loaded, lighter vessel may lose support from the now-deflected common beam. The resultant gap between load transducer and vessel bracket not only nullifies vessel calibration, but also allows vessel to rock.

Symptom Weigh system output changes and may oscillate although no change in contents has occurred as one load transducer gaps and vessel rocks.

Remedy Use three-point supports to eliminate possibility of gapping. Do not use a common support member between two adjacent vessels. See Structural Design section for preferred vessel support arrangements.

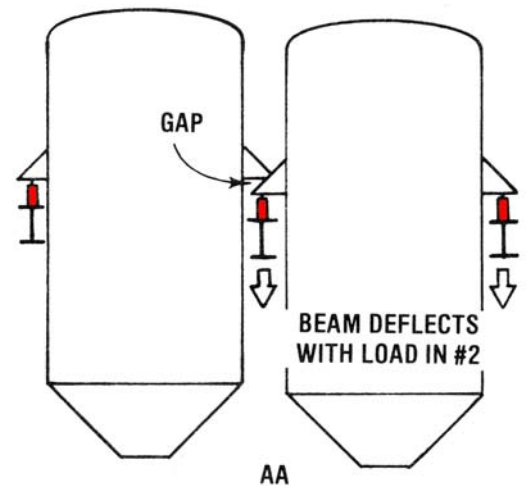
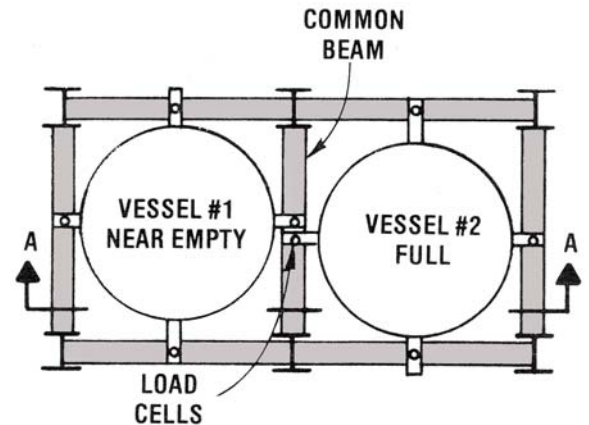

Use three-point supports to eliminate possibility of gapping

Problem Separate weigh vessels are connected to a common run of pipe. Without flexible connections, the common drain pipe will be partially supported by both (in this illustration) vessels. Thus a drain operation from one vessel causes an apparent weight increase in the other vessel for the duration of the operation.

Symptom Output of one vessel shifts with operations at connected vessel.

Remedy Install a flexible pipe coupling after the tank output valve (for all tanks sharing the common pipe). This prevents individual tank activity from affecting other tanks.

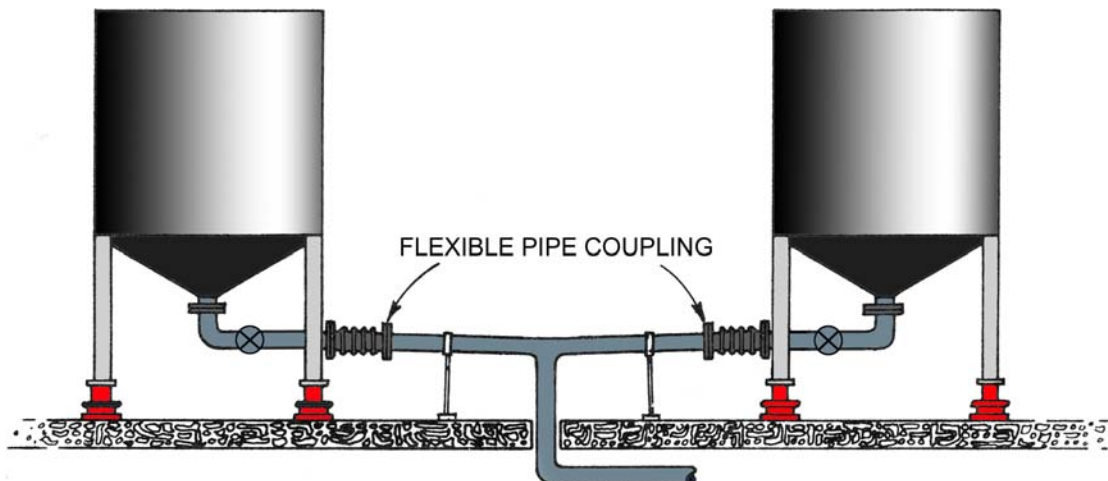

Install flexible pipe coupling for each tank sharing the common drain

Outdoor installation recommendations

- **Rigid vessel support foundations are essential. Foundations that heave, sink, or otherwise shift with time alter the initial level of the vessel and thus, the support reactions seen by the load cells/modules.**
- **Consider a shelter for the vessel when system accuracy better than 1/4% is required and when high wind, snow, or ice conditions are prevalent. Snow and ice alter the vessel tare weight while wind forces may impose positive or negative lift on the vessel; all unpredictably.**
- **Piping expansion loops or flexible piping connections are essential to accommodate differential thermal expansion between vessel, piping, and piping support structure, and to allow unrestricted deflection of load cells.**
- **Platforms and ladders attached to a weigh vessel should be totally supported either by surrounding structure or foundation, or by weigh vessel alone. Contact with any other vessel, structure, or foundation can couple the weigh vessel to it, causing unpredictable readout errors.**
- **A free-standing blind of sheet metal or a wrap of thermal insulation is advisable for load cells directly subjected to radiant heat or wind chill. The nonuniform thermal gradients produced in the load cell by these environmental effects cause temporary zero shifts in signal outputs.**

Piping expansion loops or flexible piping connections are essential to accommodate differential thermal expansion between vessel, piping, and piping support structure, and to allow unrestricted deflection of load cells

Arc welding on a weigh vessel

- **THE DAMAGE MECHANISM IS HEAT:**

Welding can damage a load transducer only if welding current passes through the transducer; induced voltage will not harm the load transducer. When several hundred amps pass through the steel element of a load transducer, resistance (I^2R) heating occurs. Should the element temperature exceed several hundred degrees Fahrenheit, the adhesive that bonds the strain gages to the element will begin to decompose. In short, welding across a load transducer will very likely cause irreparable damage to the unit. Vishay BLH strongly recommends using simulated (dummy) load cells or beams until welding and vessel construction is complete. Welding current cannot harm dummy beams in any way and live cell replacement after welding is very easy.

- **ARC WELDING PRECAUTIONS:**

Before load cell installation...

Perform as much vessel fabrication as possible prior to load transducer installation. Whenever possible, use simulated load cells (dummy beams) in place of “live” load cells until fabrication is complete. See Accessory sections for installation detail.

If dummy beams cannot be used...

Attach the welder ground lead directly to vessel, preferably adjacent to weld site. When this is not possible, put high-current-capacity cables across each load transducer to ground vessel to structure.

DO NOT rely on stay rods or piping for grounding; rods generally have high resistance terminations, while the piping may contain nonconductive flexible couplings.

Where routine welding maintenance is anticipated, permanent ground cables are advised. Braided copper automotive ground straps are suitable for this purpose.

Welding can damage a load cell or weigh module only if welding current passes through the transducer, therefore, use simulated load cells or dummy beams during vessel construction

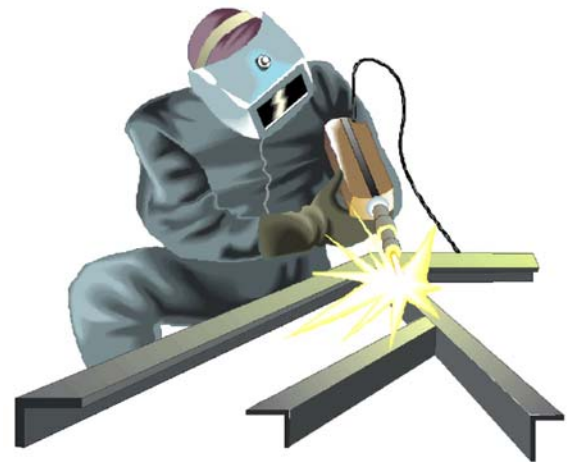

Perform as much vessel fabrication as possible prior to load cell installation

A weigh vessel, without any mechanical attachments, fully supported by load transducers mounted on a firm base will demonstrate a system accuracy approaching that of load transducer and instrumentation alone, a value well below 0.1 %. If lateral restraints are now added in the form of stay rods attached to nearby floor brackets, system accuracy should remain undisturbed, provided that installation rules are observed. A similar statement can be made for vented weigh vessels since inlet and outlet piping need not contact vessel; simply pass inlet piping through an oversize clearance hole in the top of the vessel (when there is an upper surface) and let outlet piping lead into a funnel arrangement underneath. Details are presented in the section titled ‘Piping Design.’

When problems do arise, they generally involve sealed systems requiring piping to be attached directly to vessel. Here piping is an active part of the weigh system; any motion of the vessel relative to piping and vice versa will generate vertical and horizontal reaction forces on the weigh vessel. Rules governing the magnitudes of these forces are the subject of this section.

Design criteria

The total vertical force, V , generated by the deflection of all piping attached to a weigh vessel should not exceed a percentage of the maximum live load, L , proportional to the required weigh system accuracy, A ...

$$V < (10A)L$$

where: A = system accuracy, in percent
Hence, for a 0.1 % system, $V < 1.0\%L$;
for a 0.25% system, $V < 2.5\%L$;
for a 0.5% system, $V < 5.0\%L$;
for a 1.0% system, $V < 10.0\%L$.

This total vertical piping force represents the sum of individual vertical piping reactions, P_p , generated by differential motion between pipe anchorages (i.e., the point of attachment on vessel and first pipe support) and by thermal expansion in vertical segments of pipe located between anchorages. These forces often can and should be minimized by mounting first pipe support to vessel support structure and using only horizontal piping runs between vessel and first pipe support.

The force criterion is intended to maintain highly linear piping response suitable for the most accurate weigh systems, yet permit increasing amounts of nonlinear forces to develop without impairing the required weigh system accuracy. It follows that more care and expense is required for the design and installation of piping on a high accuracy vessel than for a low accuracy vessel.

continued on the following page

When piping problems arise, they generally involve sealed systems requiring piping to be attached directly to the vessel, where piping is an active part of the weigh system

Design criteria (continued)

The total vertical deflection, δ_v , to be evaluated for each run of pipe attached to a weigh vessel is equal to the algebraic sum of all imposed deflections...

$$\delta_v = \delta_s + \delta_{tv} + \delta_{tp} + \delta_a$$

where: δ_s = vessel support deflection

δ_{tv} = vessel thermal expansion to point of pipe attachment (e.g., nozzle or flange)

δ_p = pipe thermal expansion in vertical runs of pipe

δ_a = deflection of first pipe support or anchorage, a value often independent of vessel support structure

When several combinations of deflections are possible, determine which is the limiting condition and base the piping design on it

Deflections tending to increase indicated vessel weight are given positive signs, and vice versa.

When several combinations of deflections are possible, determine which is the limiting condition and base the piping design on it. For example, a weigh vessel on one floor may be directly attached to a storage vessel on floor above (as illustrated on the next page). Assume there is no other attached piping present. If weigh vessel is fully loaded when storage vessel is empty, $\delta_a \approx 0$, but, δ_s (and thus δ_v) may be -0.5 inch (12.7 mm). At some later time, the storage vessel may be filled causing an anchor motion of, say 0.25 inch, so that $\delta_a = +0.25$ inch (6.35 mm) and $\delta_v = -0.25$ inch. For this simplistic example, the limiting case is when the weigh vessel alone is fully loaded.

The minimum vertical deflection, δ_v , to be applied to any pipe is -0.100 inch (-2.54 mm). Use this value whenever more significant deflections cannot be identified; it is intended to cover the dimensional change of load transducer under live load - generally under 0.010 inch (0.254 mm), as well as a modest amount of cold-springing required for initial pipe alignment.

A more common situation is that of a weigh vessel supported from a building floor or steel framework. Such vessel support structures generally exhibit maximum vertical deflections of 0.25 inch (6.35 mm) to 0.50 inch (12.7 mm) under gross vessel weight, although some installations have deflections approaching 0.75 inch (19.05 mm). If a realistic evaluation can be performed for the maximum vessel support deflection, let δ_s be the resulting value. Otherwise, take $\delta_s = 0.50$ inch as a reasonable estimate.

Design criteria (continued)

Vessel thermal expansion, δ_{tv} , is determined from the expression:

$$\delta_{tv} = L\alpha\Delta T$$

where: L = distance between vessel plane of support and pipe attachment point

α = coefficient of thermal expansion, with max. values of $9.6 \times 10^{-6}/^{\circ}\text{F}$ ($1.7 \times 10^{-5}/^{\circ}\text{C}$) for stainless steel and $6.0 \times 10^{-6}/^{\circ}\text{F}$ ($1.1 \times 10^{-5}/^{\circ}\text{C}$) for carbon steel.

ΔT = maximum vessel operating temperature minus ambient temperature.

Pipe thermal expansion, δ_{tp} , is evaluated as indicated above except that L is now defined as the sum of the lengths of vertical pipe segments between weigh vessel and first pipe support. This parameter may be ignored when pipe expansion is below 0.050 inch (1.27 mm).

Pipe anchor deflection, δ_a , is a significant factor in weigh system performance. Refer to the sources of floor deflections in section entitled, "Special Design Considerations" before assigning a value.

NOTE: It remains the responsibility of the vessel or pipe designer to ensure that the level of stresses in piping, vessel attachments, and pipe supports is in accordance with applicable piping and vessel design codes. It is also incumbent upon the designer to ensure that forces and moments imposed on associated process equipment by vessel piping are within limits specified by equipment manufacturer.

DISCUSSION OF DESIGN CRITERIA-
In applying the vertical force rule, the piping designer must assign realistic values of deflection to each piping run attached to the vessel. This means that vessel support deflection, vessel thermal expansion, pipe support deflection, and pipe thermal expansion should be considered.

Pipe anchor deflection, δ_a , is a significant factor in weigh system performance

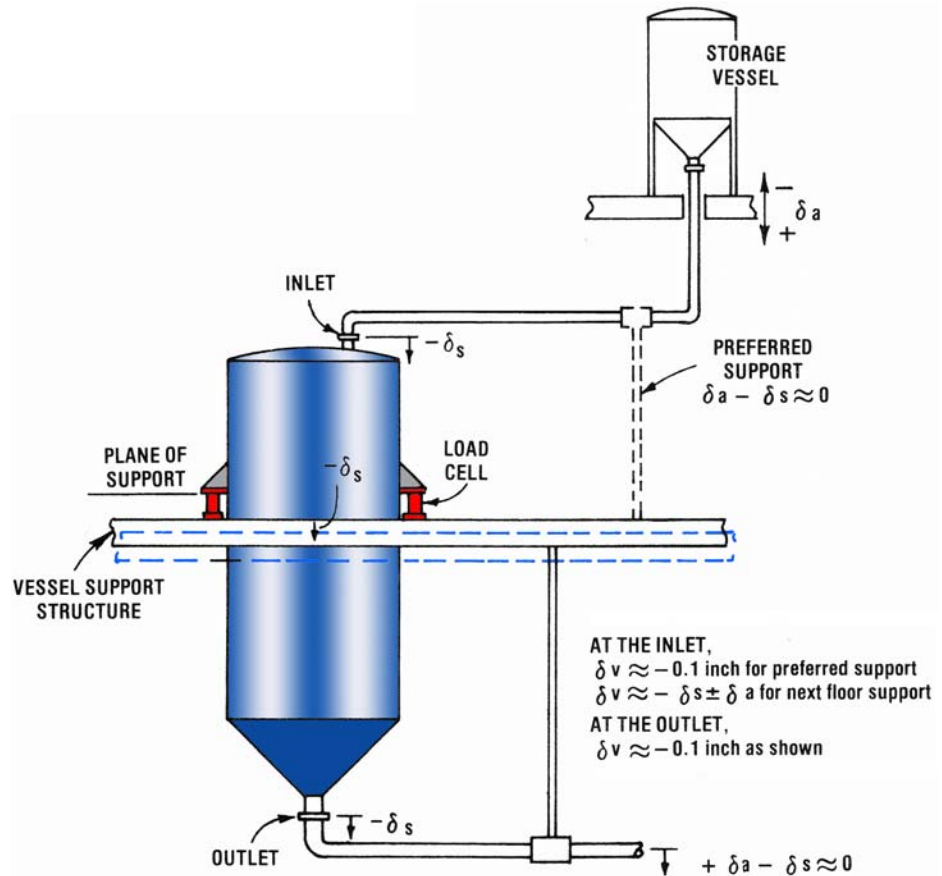

Support all piping from vessel support structure so that attached piping moves only with vessel, isolating the weigh system from motion of other floors and equipment

Design criteria (continued)

DISCUSSION OF DESIGN CRITERIA (continued)

For example, the vessel at constant ambient temperature shown on the previous page generates a vertical pipe reaction at the inlet as vessel support structure deflects an amount δ_s that varies with load; significant pipe forces are precluded at vessel outlet by attaching first pipe support to vessel support structure, thereby minimizing differential motion between pipe and vessel.

For this case, it is obviously beneficial to support all piping from vessel support structure so that attached piping moves only with vessel, isolating weigh system from motion of other floors and equipment. Whatever forces do develop are primarily due to installation fit up and are essentially constant, contributing only to vessel tare weight.

Design the piping runs from vessel to first supports with sufficient flexibility to meet vertical force criterion consistent with system accuracy required.

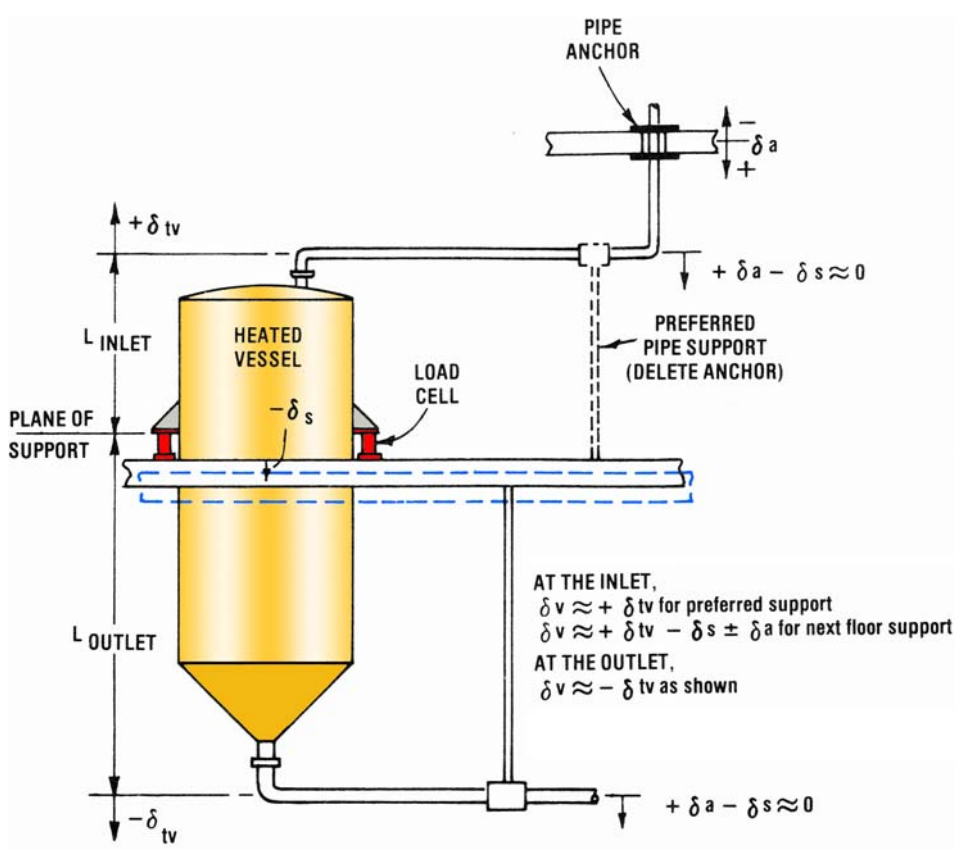

Let the vessel now operate at some constant temperature above ambient. As indicated below, vessel thermal growth affects both inlet and outlet piping. Estimate vessel expansion at each end of vessel from

$$\delta_v = L\alpha\Delta T$$

as previously discussed. Vertical displacements at both inlet and outlet are the algebraic sum of:

$$\delta_v = \delta_{tv} + \delta_s + \delta_a$$

It is again beneficial to support all piping from the vessel support structure to achieve weigh system isolation. In fact, the only difference between this case and the first is the need for additional flexibility of each piping run to assure a linear response to vessel deflection with load in spite of imposed thermal expansion.

Design criteria (continued)

DISCUSSION OF DESIGN CRITERIA (continued)

Lateral piping forces are seldom significant for weigh vessels fully supported on load transducers: the requirement for vertical flexibility automatically imparts a degree of lateral flexibility to attached piping; the lateral force resultant is reacted by the lateral restraints; and the net overturning moment, while partially unloading a load transducer(s) on one side of the vessel, merely adds load onto load transducer(s) on the other side without a change in indicated vessel weight. Rarely is the overturning moment large enough to actually lift the vessel and cause gapping to occur between load transducer and vessel.

Lateral piping forces are more likely to cause problems for weigh vessels partially supported on load transducers since any overturning moment that arises is likely to alter the weigh system output. Refer to the 'Piping Design' section for suggestions on minimizing piping influence.

Design analysis for piping

INTRODUCTORY COMMENTS-The information presented herein will enable the reader to estimate the total vertical piping force acting on a vessel. If this resultant force exceeds live load criterion, action should be taken to introduce additional flexibility into the piping system. This may be accomplished, for example, by increasing the horizontal length of piping between vessel and first pipe support, redesigning attached piping to include a right angle segment or expansion loop, inserting a flexible device, or specifying a lighter schedule pipe. Refer to "Piping Design" section for suggestions.

Specific designs for piping cannot be pre-engineered for limiting cases and presented in design charts, as for stay rods. There are few, if any, "standard" piping configurations. Identical vessels installed in different buildings will still require customized piping runs to accommodate changes in floor height and stiffness or associated equipment. Hence, the piping design analysis is necessarily left in basic form.

Two figures presented in this section show pipe spring rate as a function of span length for Schedule 40 pipe and, a more general chart, spring rate as a function of span length and pipe moment-of-inertia. These figures yield conservative, high-side values for spring rate that may be modified by factors derived on the following page.

continued on the next page

Pi represents the vertical reaction force developed in one straight span of pipe

Design analysis for piping (continued)

PIPING FLEXIBILITY OVERVIEW- The vertical reaction force, P_i , developed in one straight span of pipe in response to differential vertical motion, δ_{vi} , between fixed end points is:

$$P_i = K_i \delta_{vi}$$

where: K_i = spring rate, or pipe stiffness

For all piping attached to a weigh vessel, the summation of individual pipe reactions, P_i , should meet the vertical force criterion...

$$V = |\sum P_i| = |\sum K_i \delta_{vi}| < (10A)L$$

where: A = system required accuracy, in percent
 L = maximum live load.

The points discussed hereafter are intended to aid in estimation of overall vertical piping forces acting on a weigh vessel as piping layout is being generated. More accurate force values, when warranted, may be obtained by using computer programs specifically written for piping analyses.

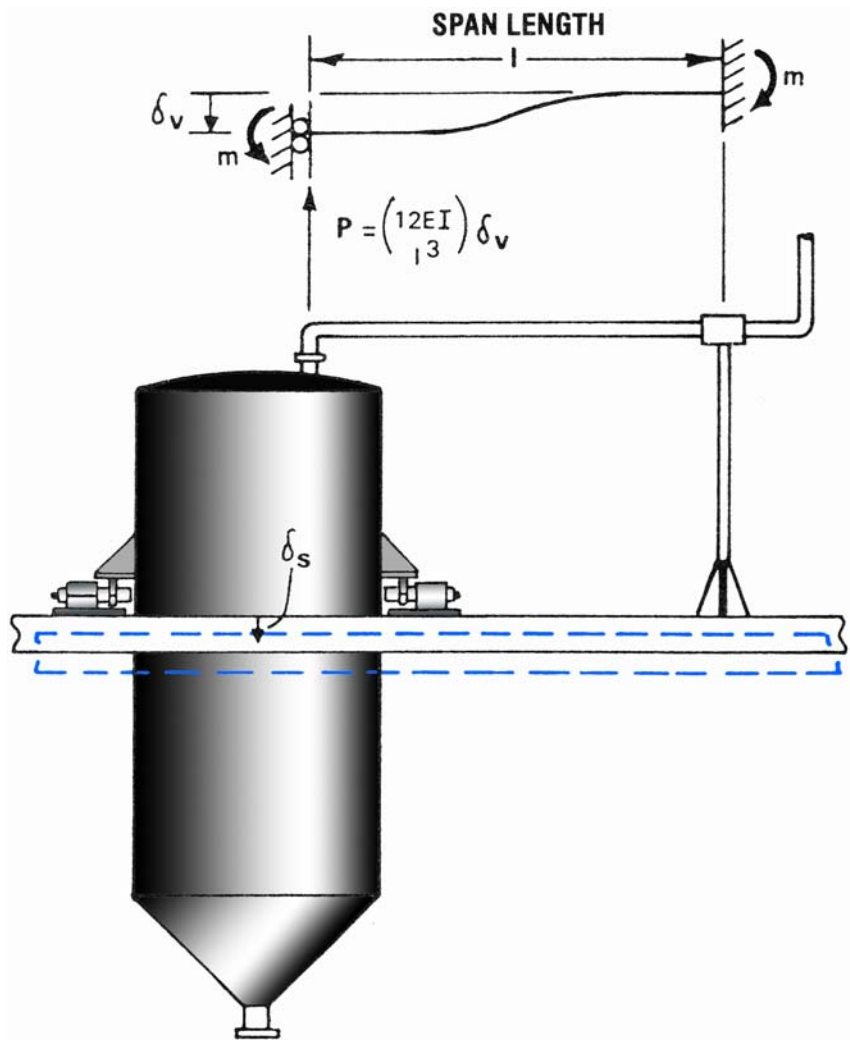

SPRING RATE, K -As indicated above, the stiffness of a pipe fixed at one end against all deflection and rotation, and guided at the other is given as:

$$K = \frac{12EI}{l^3}$$

This value represents an upper bound that is not achievable because of inherent flexibility of vessel nozzles, flanges, or wall itself, and of the pipe support. The piping industry recognizes this and generally uses:

$$K = \frac{10EI}{l^3}$$

for average runs, a compromise between a beam with fixed ends (above) and

$$K = \frac{8EI}{l^3}$$

for a beam simply supported at both ends*.

*M. W. Kellogg Company, Design Of Piping Systems, 2nd Edition, John Wiley & Sons, pg. 239.

Design analysis for piping (continued)

SPRING RATE, K (continued)

The spring rate developed in the charts on the next two pages are based upon the theoretical fixed end condition with an additional design factor of two applied. For this analysis, these spring rates

should be derated by a ratio of $\left(\frac{10}{24}\right)$ or 0.42.

Thus, the corrected vertical force equation should read, $P = 0.42K \delta_v$, where K is read directly from the Figures.

NOTE: Effective length for a non-horizontal pipe span is equal to its projected length on the horizontal plane; $l = L \cos A$. A vertical run of pipe has zero span length, and may be considered to have infinite stiffness for the purposes of this analysis.

FLEXIBILITY TRENDS-To increase the flexibility of a straight run of pipe, add a horizontal leg at right angles. The straight run now benefits from both bending and torsional deflection of the leg. For example, consider a pipe span, cantilevered from a “rigid” anchor, with an enforced deflection, Y at the free end. The vertical reaction, W_o is:

$$W_o = \left(\frac{3EI}{a^3}\right)y$$

If a right angle leg of length b is now added, the reaction becomes:

$$W \approx \left(\frac{1.68EI}{a^3}\right)y, \text{ or } 56\% W_o \text{ when } b = .2a$$

$$W \approx \left(\frac{EI}{a^3}\right)y, \text{ or } 33\% W_o \text{ when } b = .5a$$

$$W \approx \left(\frac{EI}{2a^3}\right)y, \text{ or } 17\% W_o \text{ when } b = a$$

FINAL VERTICAL FORCE EQUATIONS-Assuming these trends to hold for the fixed-guided condition and rounding up for a modest element of conservatism, the pipe reaction force, P, becomes:

- $P \approx 0.5K \delta_v$ for a straight run of pipe
- $P \approx 0.3K \delta_v$ for a right angle bend with $b = .2a$
- $P \approx 0.2K \delta_v$ for a right angle bend with $b = .5a$
- $P \approx 0.1 K \delta_v$ for a right angle bend with $b = a$

where K is read directly from Figures on the following page. It should be understood that these equations are not exact, but are adequate for estimating the vertical piping forces for comparison with the empirical design criterion.

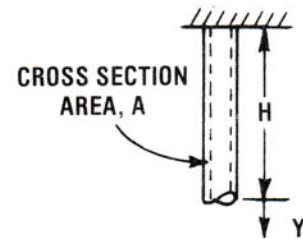
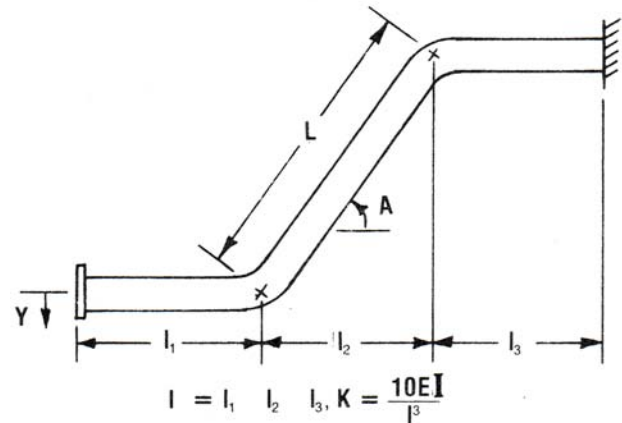

$$K_{AXIAL} \gg \text{TYPICAL } K_{LATERAL}$$

$$\frac{AE}{H} \gg \frac{10EI}{l^3}$$

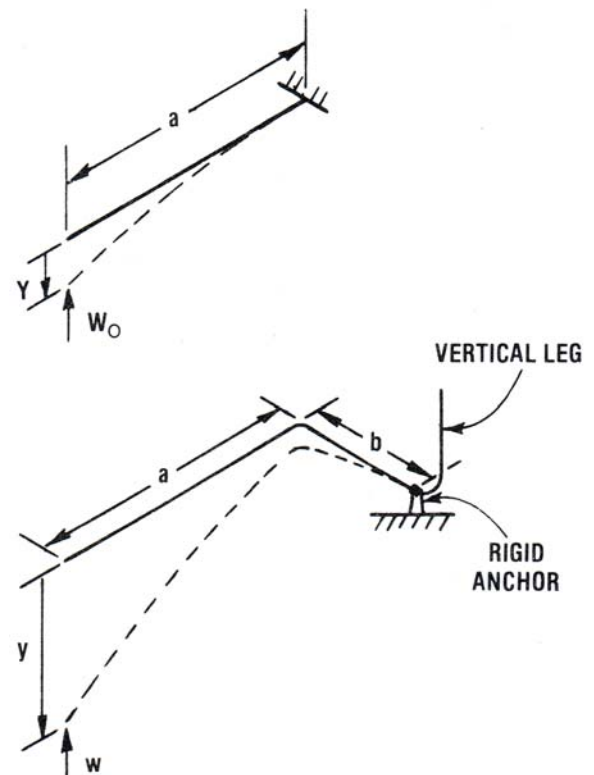

Design analysis for piping (continued)

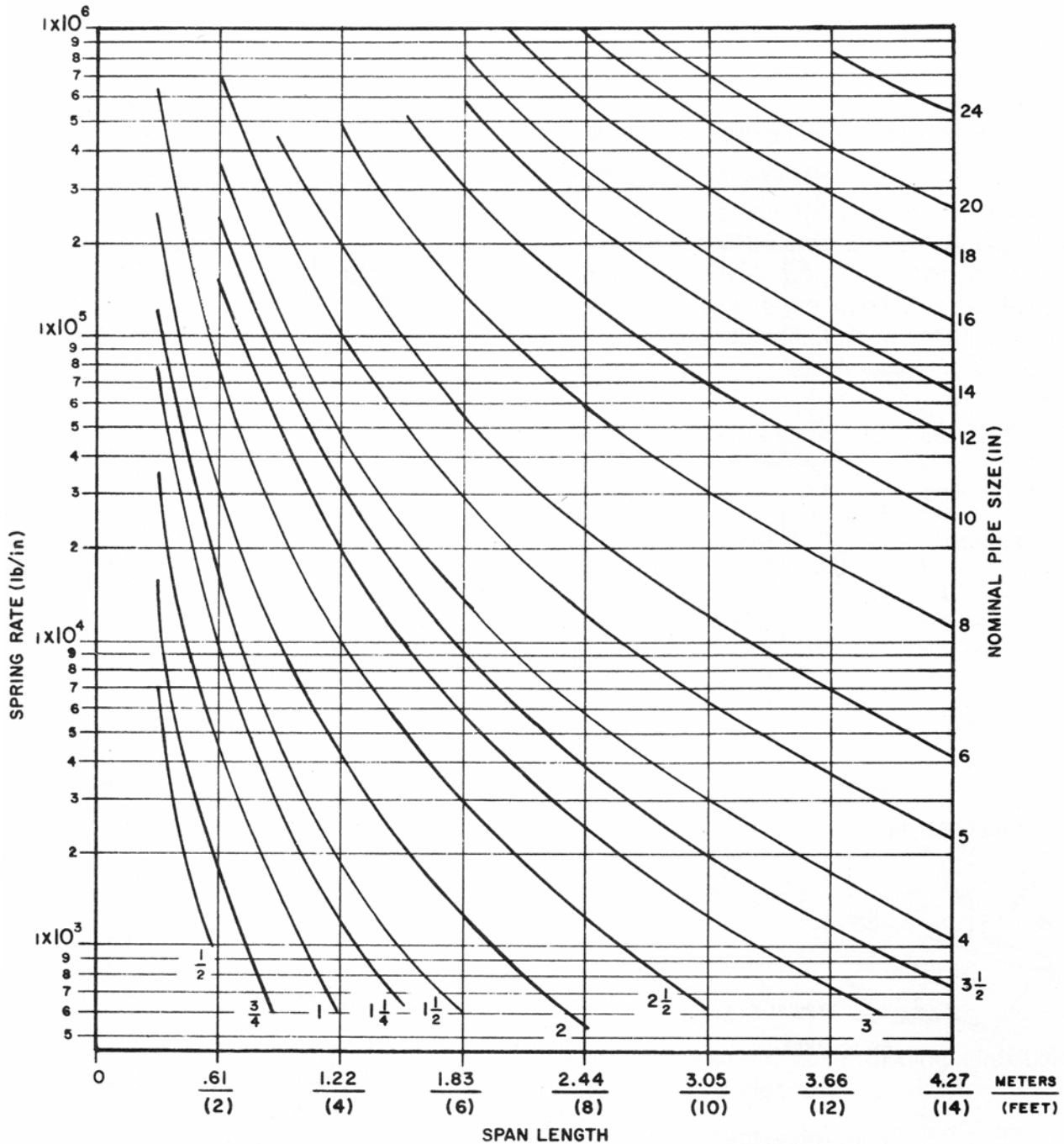

SPRING RATES FOR SCHEDULE 40 STEEL PIPE

*NOTE: Spring rate obtained from the above chart should be derated by 0.42.
(Refer to section on Spring Rate)*

Design analysis for piping (continued)

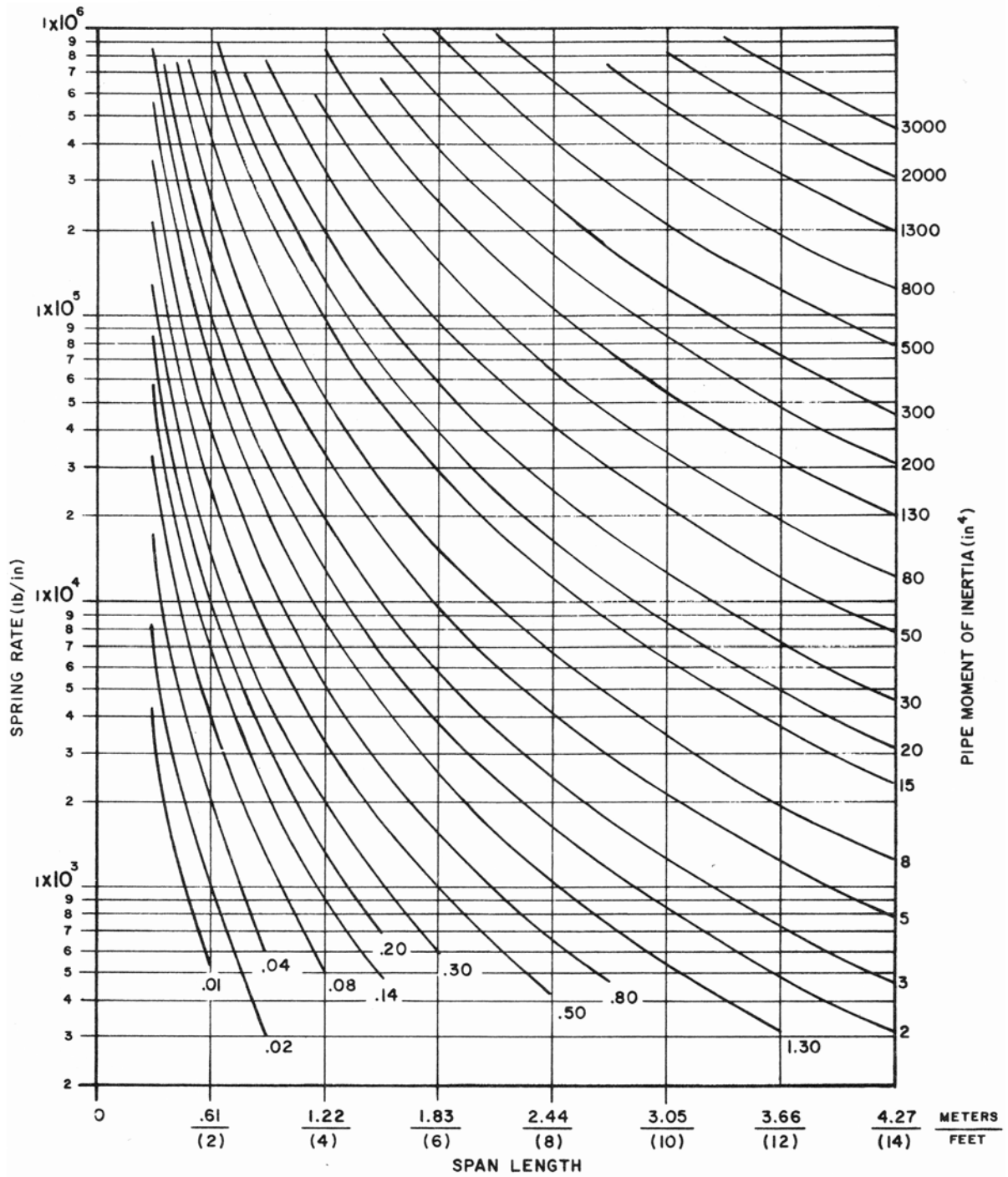

SPRING RATES FOR STEEL PIPE

NOTE: Spring rate obtained from the above chart should be derated by 0.42.
(Refer to section on Spring Rate)

NOMINAL PIPE SIZE (mm/in.)	STEEL PIPE	
	Sch 40 (kg/lb)	Sch 10S (kg/lb)
76.20	325	204
3.00	715	450
304.80	34,050	14,755
12.00	75,000	32,500

NOMINAL PIPE SIZE (mm/in.)	STEEL PIPE	
	Sch 40 (kg/lb)	Sch 10S (kg/lb)
76.20	66	41
3.00	145	90
304.80	6810	2950
12.00	15,000	6500

Stiffness of flexible devices

A misconception regarding flexible devices such as expansion joints and flexible couplings is that, once installed, they accommodate all motions imposed upon them without significant force reactions. That this is generally untrue is shown in the Table at left and illustration below, where several different piping layouts are compared, leading to the observations and notes on the following page.

EXPANSION JOINT¹ - VERTICAL

MINIMUM (mm/in.)	L	STEEL (kg/lb)	MINIMUM (mm/in.)	L	TEFLON (kg/lb)
238		123	92.10		27.20
9.375		270	3.625		60
356		141	200		43.10
14.00		310	7.875		95

EXPANSION JOINT¹ - HORIZONTAL

MINIMUM (mm/in.)	L	STEEL (kg/lb)	MINIMUM (mm/in.)	L	TEFLON (kg/lb)
238		329	92.10		47.70
9.375		725	3.625		105
356		1105	200		114
14.00		2435	7.875		250

UNIVERSAL JOINT²

MINIMUM (mm/in.)	M	STEEL (kg/lb)	TEFLON (kg/lb)
689		2.72	1.82
27.13		6	4
883		20.43	8.17
34.75		45	18

Vertical reaction forces generated by a 0.25-inch (6.35 mm) end deflection

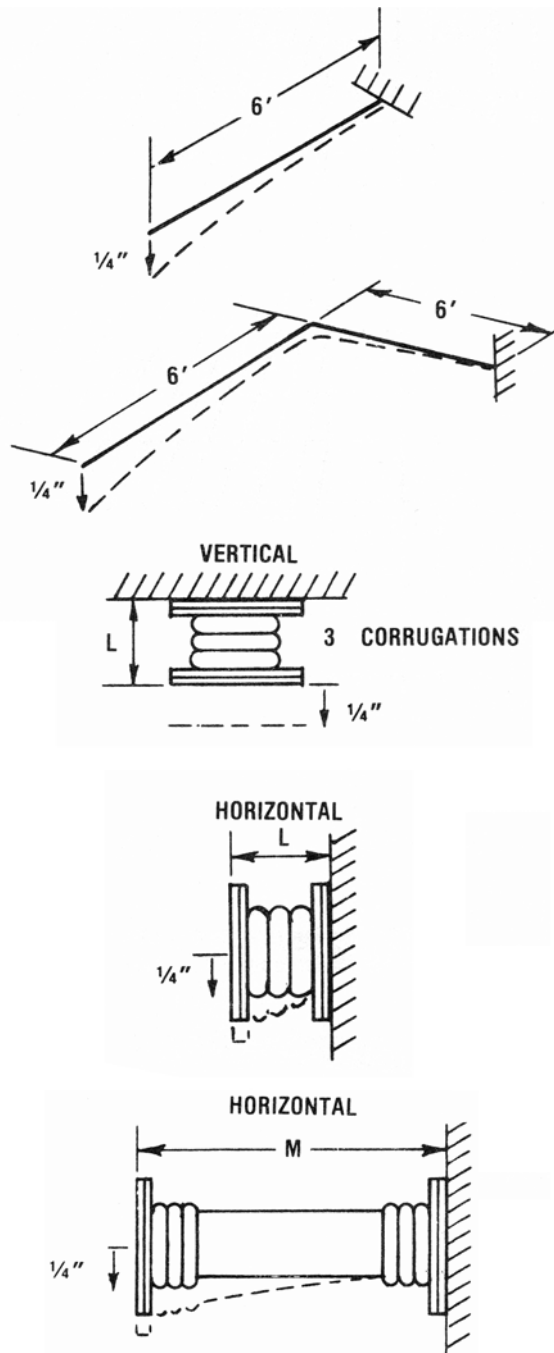

Stiffness of flexible piping devices (continued)

OBSERVATIONS:

- (1) The use of horizontally-positioned universal joints is recommended whenever spatial requirements preclude the use of much longer offset piping runs. It is incumbent upon the piping designer to request applicable stiffness data from the manufacturer of the flexible fitting prior to finalizing his piping layout.
- (2) Lighter schedule stainless steel piping (e.g., schedules 10S and 5S) offer significant improvements in flexibility over the standard heavier schedule carbon steel piping commonly used.

NOTES:

- (1) Steel expansion joint data is from Badger Industries, New Zelienople, Pa., <http://www.badgerind.com>; Teflon expansion joint data is from Peabody Dore Corporation (no longer in business), Data Sheet BR06 and Peabody Dore Drawing A-378513, "Table of Spring Forces". These steel joints are rated at 300 and 400 psi; the molded Teflon joints, at 150 psi.
- (2) Universal joints comprise two expansion joints and an intermediate length of pipe. Teflon joints are custom items from the vendor, so data is not readily available. For comparison purposes, the same percent force reduction given for the steel joint was applied to the Teflon joint.
- (3) Expansion joints and flexible couplings are made with a variety of materials, material thickness and dimensions to suit specific applications; for example, units with lower pressure ratings and greater numbers of corrugations would generate lower forces than those presented here. When inquiring of a manufacturer, stipulate the maximum stiffness required and the space available in addition to the usual information.
- (4) A flexible device installed vertically develops vertical thrust forces with the onset of vessel pressure associated with material flow and some chemical reactions. The magnitude of these forces, V , is given by $V = AP$, where A is the mean internal area of the device and P is the estimated pressure. This is one reason why such devices are best installed in the horizontal runs adjacent to a high accuracy weigh vessel.

Using horizontally-positioned universal joints is recommended whenever spatial requirements preclude the use of much longer offset piping runs

Stiffness of flexible piping devices (continued)

ILLUSTRATE PROBLEM ... PIPING FLEXIBILITY

Given:

The weigh system shown. It is an existing vessel to be retrofitted. The attached piping is schedule 40 steel except for the universal joint. An accuracy of 0.1 % is required over the maximum live load, L of 45,000 lb (20410 kg). The vessel is at constant ambient temperature. All pipe anchorages are assumed to be non-deflecting. The maximum vessel support deflection is estimated to be 0.25 inch (6.35 mm).

Discussion:

Since no vessel thermal expansion occurs and all pipe anchors are rigid, the vertical deflection imposed on each of the pipes is the same; that is, $\delta_v = -0.25$ inch

Procedure:

(1) Total vertical force - the absolute value of the total piping force permitted for this installation is:
 $V = 10AL = 10(0.1\%)L = 1.0\%L$
 $V = 0.01(45,000) = 450$ lb (204 kg)

(2) Piping stiffness, K
 Determine the appropriate pipe stiffnesses for the 4, 6, and 8-inch lines from Table:

- (4-inch, 10 ft. long) $K_1 = 3.0 \times 10^3$ lb/in.
- (6-inch, 8 ft. long) $K_2 = 2.3 \times 10^4$ lb/in.
- (8-inch, 8 ft. long) $K_3 = 5.8 \times 10^4$ lb/in.

The lateral stiffness of the 12-inch universal joint must be obtained from the manufacturer. For this problem, let $K_4 = 175$ lb/in. This assumes that the right side of the joint is to be fixed, without any allowance for the flexibility of the piping beyond that point.

(3) Vertical pipe reactions, P_i
 Since each pipe has only a straight horizontal run, the applicable equation is:
 $P = 0.5K \delta_v$

please see next page for conclusion

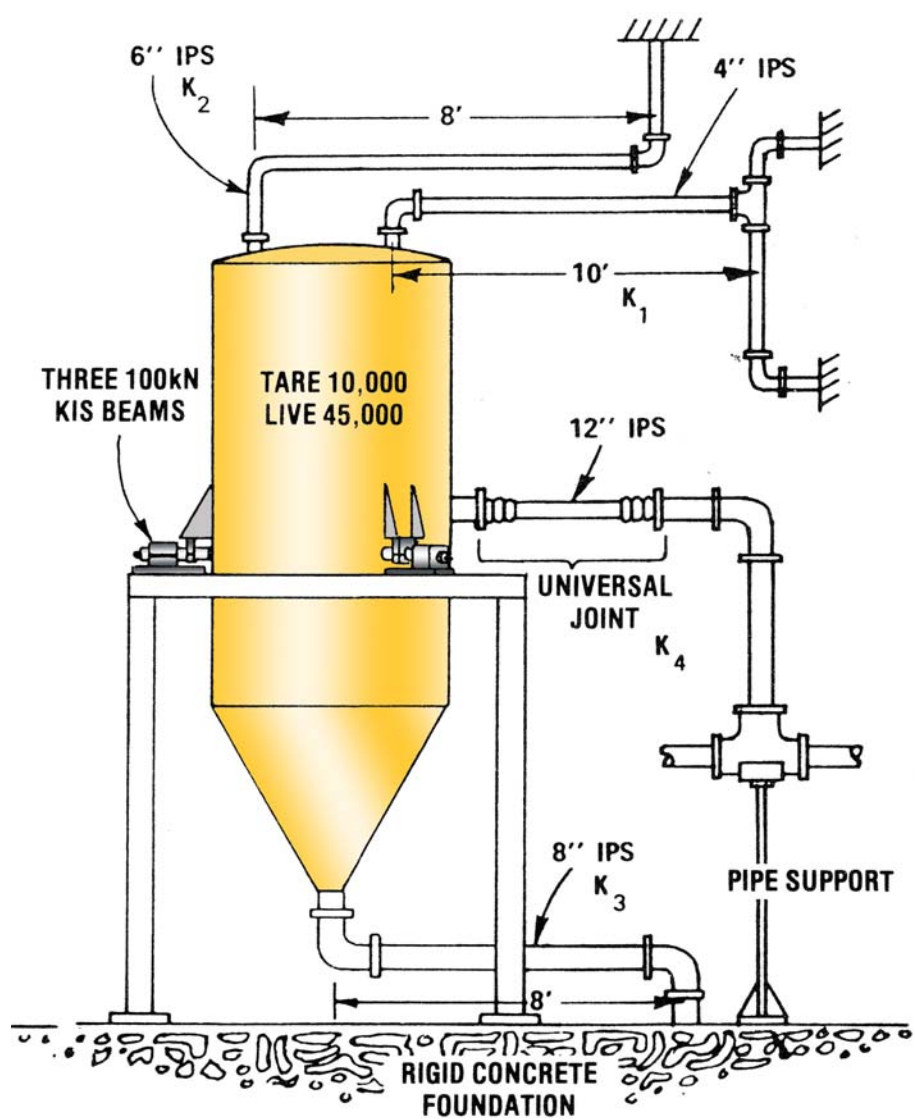

Stiffness of flexible piping devices (continued)

ILLUSTRATE PROBLEM ... PIPING FLEXIBILITY (continued)

Thus:

$$\begin{aligned} P_1 &= 0.5 (3 \times 10^3) (-0.25) = -375 \text{ lb} \\ P_2 &= 0.5 (2.3 \times 10^4) (-0.25) = -2875 \text{ lb} \\ P_3 &= 0.5 (5.8 \times 10^4) (-0.25) = -7250 \text{ lb} \\ P_4 &= K_4 V = 175(-0.25) = -45 \text{ lb} / -10545 \text{ lb} \end{aligned}$$

However,

$$V = |\sum P_i| = 10545 \text{ lb} \gg 450 \text{ lb.}$$

permitted for this installation.

Discussion:

Clearly 6- and 8-inch lines require redesign for a 0.1 % system. Possible solutions are to:

- (a) put expansion loops in both lines,
- (b) change the straight spans to schedule 10S stainless, process permitting, or
- (c) insert additional universal joints.

The first solution, (a), requires piping analysis beyond the scope of this manual. Solution (b) doesn't appear fruitful since the data in Table 1 suggests a decrease in pipe reaction of only 2 or 3 times, whereas a factor of at least 6 is required here. So, for this example, additional universal joints will be inserted.

(4) Universal joint stiffness

One manufacturer specifies the lateral stiffness for 3rd corrugation metal universal joints with 300-psi ratings at:

$$\begin{aligned} K_{6''} &= 40 \text{ lb/in. (overall length < 43 inch)} \\ K_{8''} &= 70 \text{ lb/in. (overall length < 46 inch)} \end{aligned}$$

(5) Vertical pipe reactions (2nd try)

$$\begin{aligned} P_1 &= -375 \text{ lb} \\ P_2 &= K_2 V = 40 (-0.25) = -10 \text{ lb} \\ P_3 &= K_3 V = 70 (-0.25) = -20 \text{ lb} \\ P_4 &= -45 \text{ lb} \\ \sum P_i &= -450 \text{ lb} \\ V &= 450 \text{ lb} = 450 \text{ lb} \end{aligned}$$

Discussion:

The insertion of two standard universal joints in the 6- and 8-inch lines eliminates all possibility of nonlinear piping response on this weigh system.

Chapter eight deals with several crucial structural design factors. Careful consideration of vessel support and interaction with other plant equipment will ensure premium system operation.

Support deflection

UNDER GROSS VESSEL WEIGHT

- Vessel support bracket should not tilt more than $\frac{1}{2}^\circ$
- Vessel support structure should deflect uniformly, generally less than $\frac{1}{2}$ inch (12.70 mm)
- Vessel support plane should not tilt more than $\frac{1}{2}^\circ$ due to any external event
- Load transducer support beam should not twist or warp more than $\frac{1}{2}^\circ$

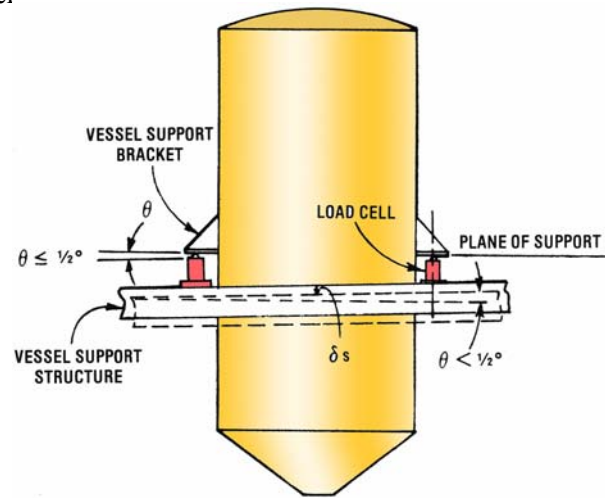

Support Bracket Tilt

SUPPORT DEFLECTION SHOULD BE THE SAME AT ALL SUPPORT LOCATIONS -

System accuracy may be compromised by:

- - Nonlinear mechanical restrictions if a vessel
 - tilts with increasing load
 - rocks with agitation or chemical reaction

SUPPORT DEFLECTION SHOULD BE LESS THAN $\frac{1}{2}$ INCH (12.70 MM) UNDER GROSS VESSEL WEIGHT

System accuracy may be compromised by:

- Nonlinear mechanical restrictions when differential motions between vessel and piping or lateral restraint supports exceed design estimates
- Excessive vessel motion if “soft” support puts system resonance near frequency of pumps, agitators, traffic, wind gusts, or violent internal chemical reactions.

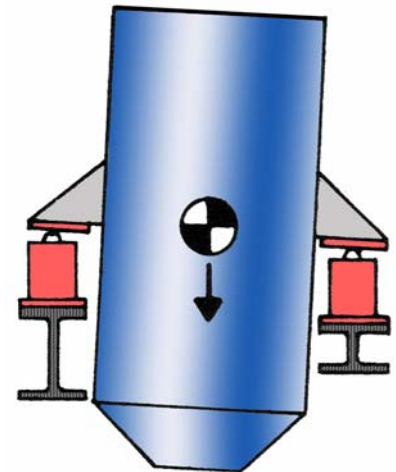

Vessel Tilts with Increasing Load

THE VESSEL SUPPORT PLANE SHOULD NOT TILT MORE THAN $\frac{1}{2}^\circ$ IN RESPONSE TO...

- Temporary events (forklift traffic, level changes in nearby vessels, etc.)

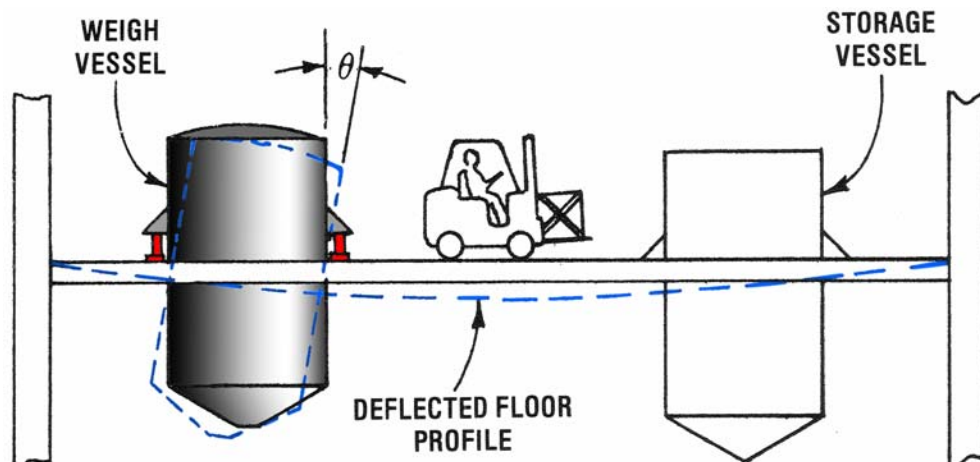

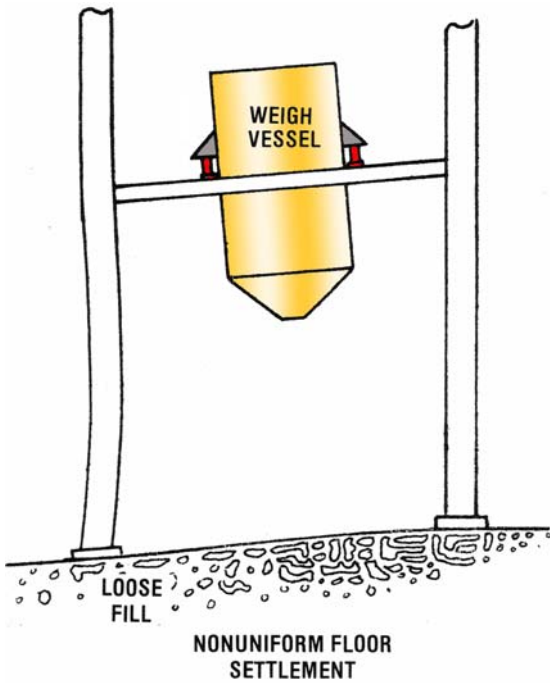

Support deflection (continued)

THE VESSEL SUPPORT PLANE SHOULD NOT TILT MORE THAN $\frac{1}{2}^\circ$ IN RESPONSE TO...

- Permanent events
- Tilting of the support plane causes a 'cosine error' in the load transducers, where signals decrease by $1/\cos \theta$, θ being the tilt angle. The readout indicates less material than is actually in the vessel. Tilting is likely to create unanticipated mechanical restrictions as attached piping is displaced laterally by the vessel.

Load transducer/ support beam alignment

ALIGN LOAD CELL WITH BEAM CENTERLINE TO AVOID TWISTING OF BEAM WITH LOAD, SO THAT SYSTEM CALIBRATION ACCURACY IS NOT COMPROMISED.

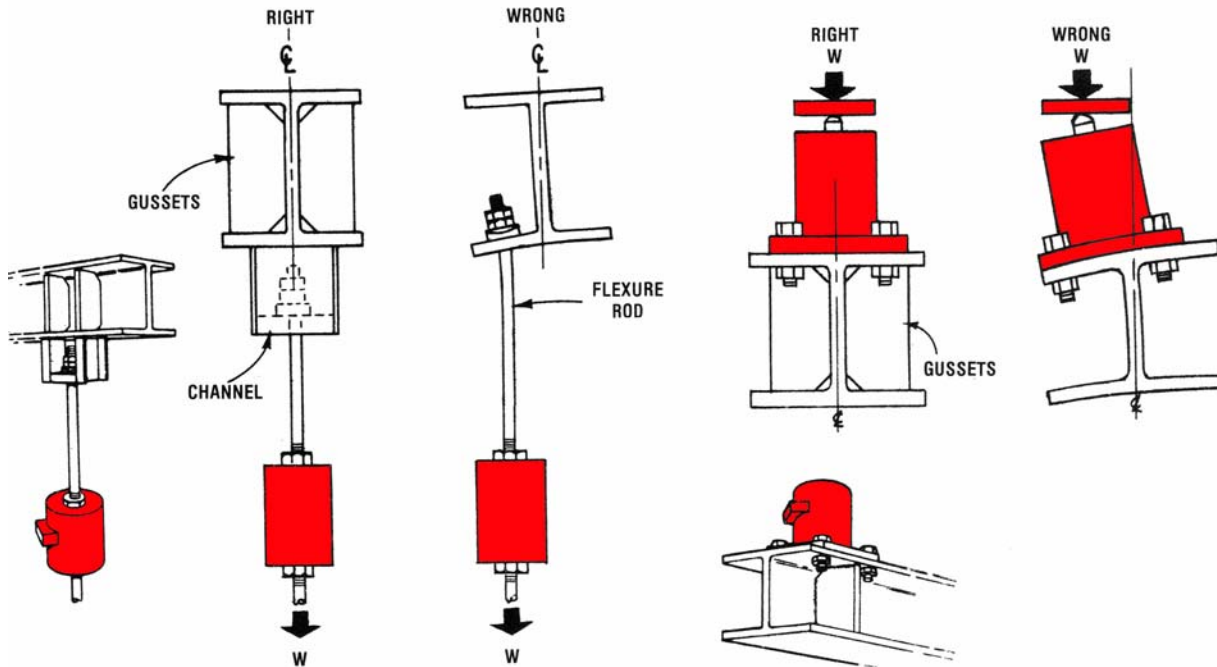

Correct and incorrect methods of load cell alignment

Diagonal beam support

Locate load cells close to vertical columns to minimize support deflection and tilting of the load cell due to side loads.

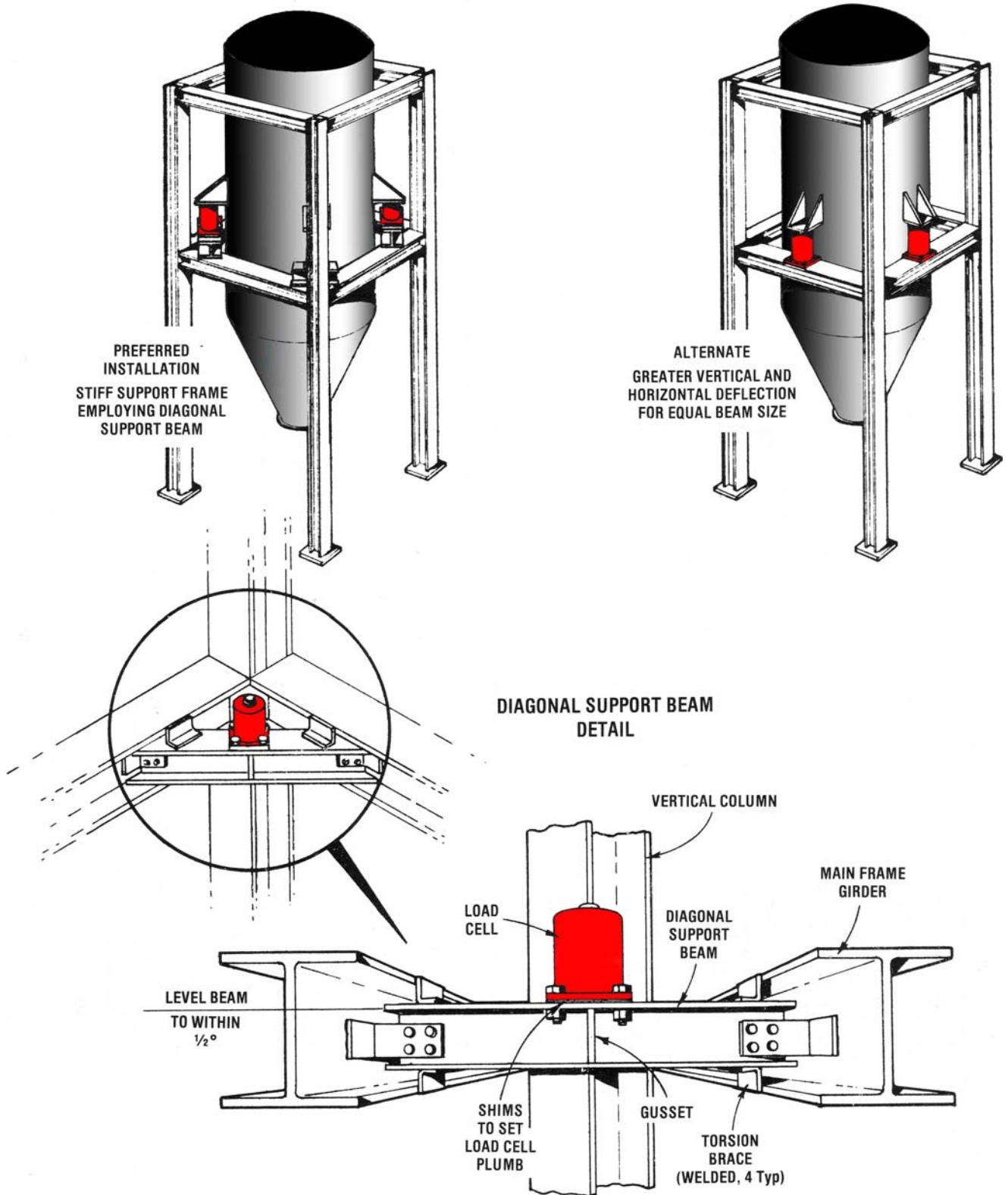

Diagonal beam support (continued)

PREFERRED ARRANGEMENT

- Provide above floor access to facilitate load transducer installation
- Vessel weight carried safely in compression, not shear
- Lateral restraint brackets may fit directly on the beam as well (Lateral restraints are usually not necessary for weigh module installations)

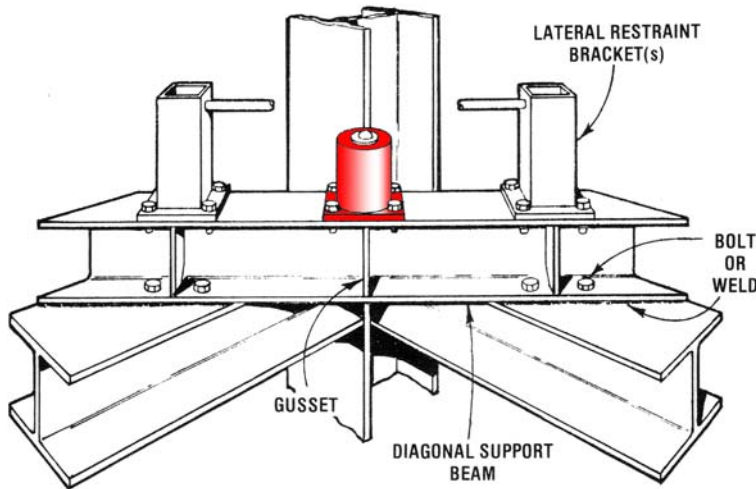

Load cell mounting - preferred arrangement

Vessel interaction

When weighing adjacent vessels, structurally isolate one from the other to minimize cross-talk or interaction between them. Otherwise, weight changes in one vessel will affect the readout of the adjacent vessel.

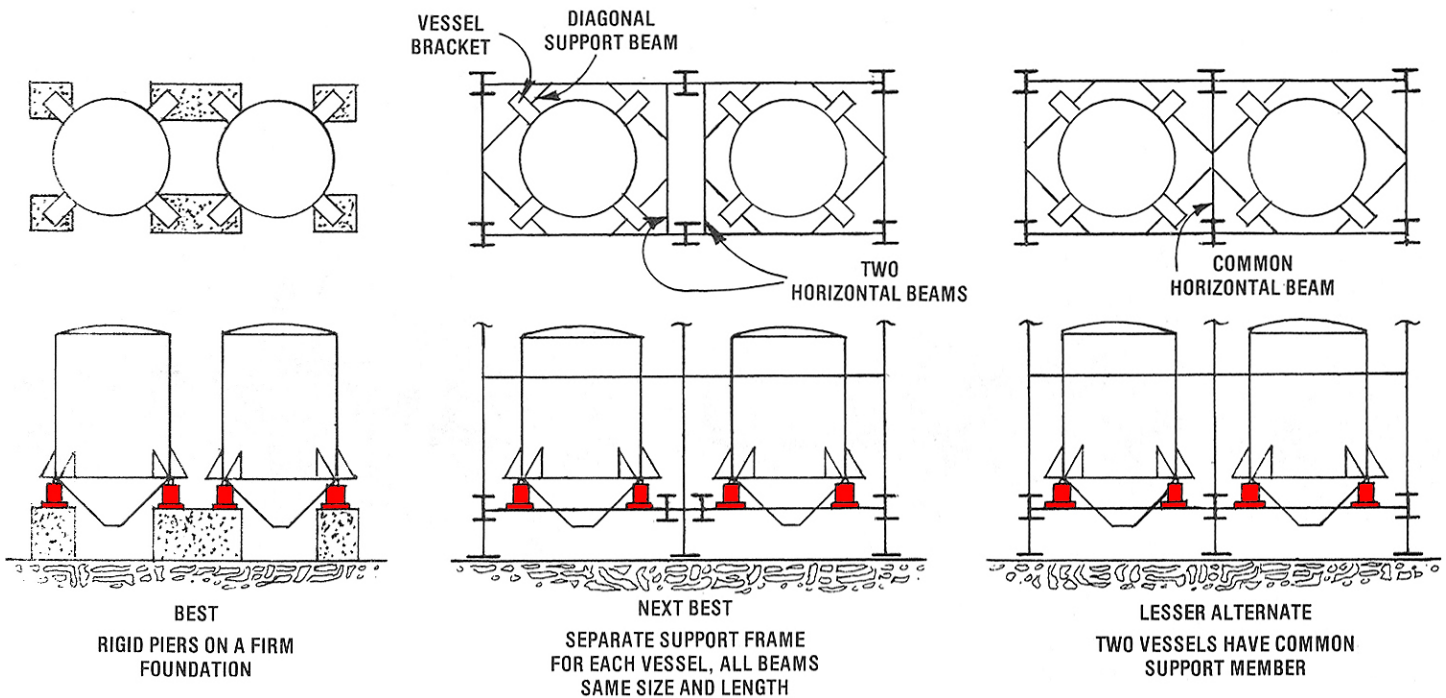

Adjacent vessel mounting arrangements

Stiffening existing structures

Excessive support structure deflections are undesirable for many reasons. (Refer to Vessel, Piping, and Support Deflections). Should it become necessary to stiffen an existing vessel support structure, the following suggestions may be of interest.

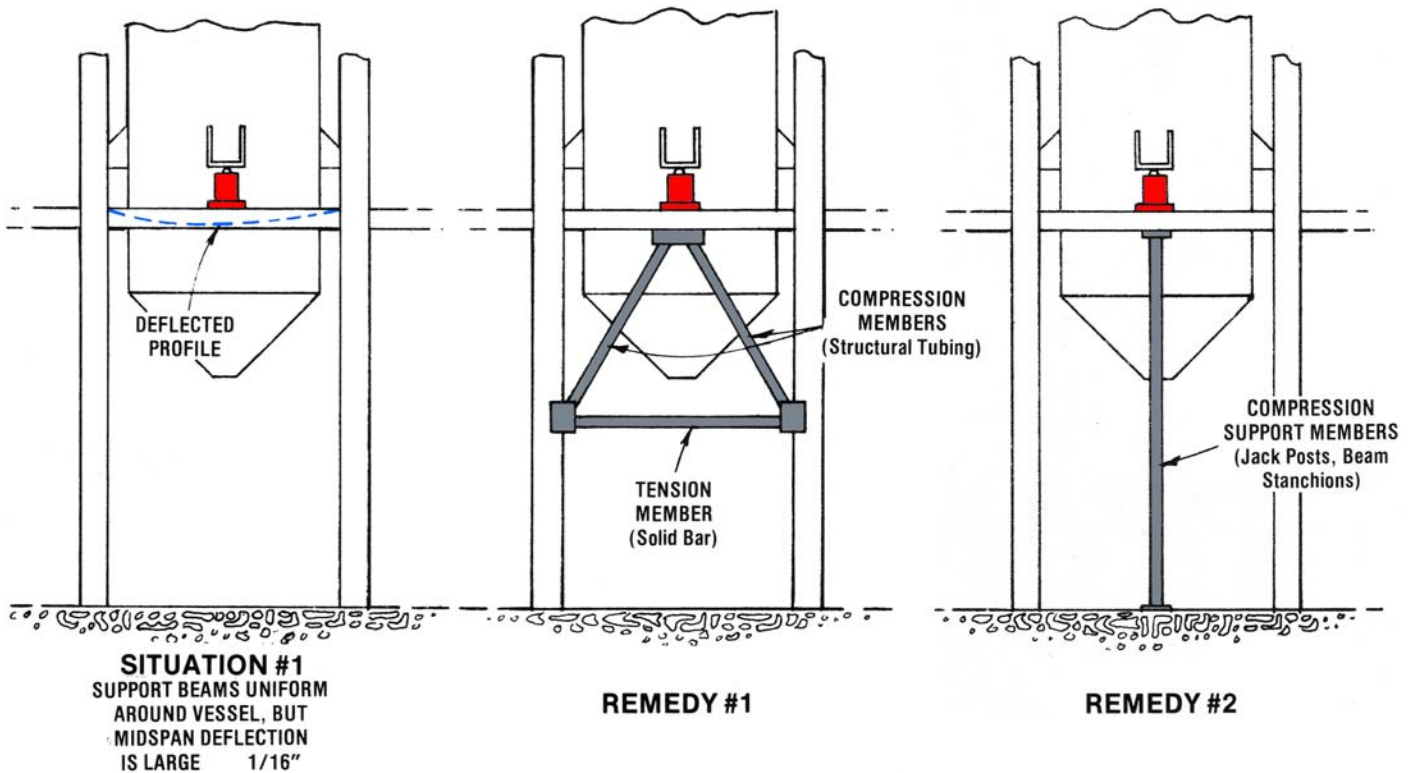

Two cases of structural stiffening problems and their remedies

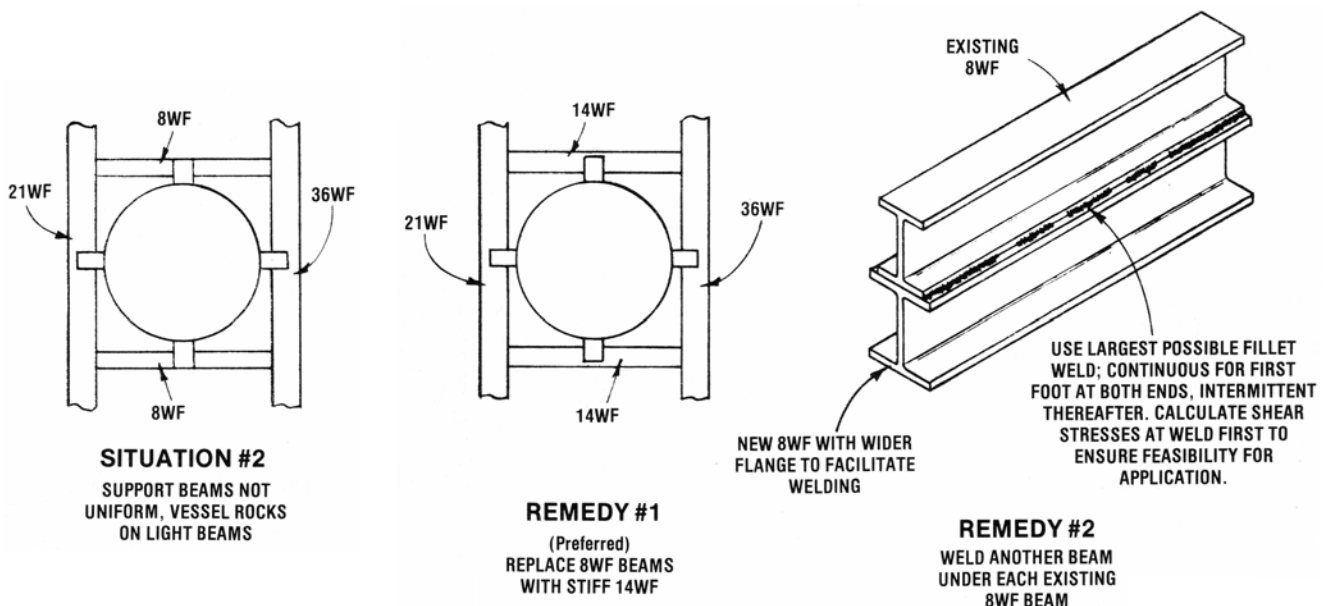

Weigh module installations typically do not require stay or vertical restraint rods

Support details - weigh modules

- Mounting plate or retainer yoke bolts directly to vessel support bracket
- Base plate mounts directly to support beam or foundation grout pad
- Stay rods typically not necessary
- Vertical restraint rods typically not necessary
- Provision for jacking (simplifies installation, maintenance and field calibration)

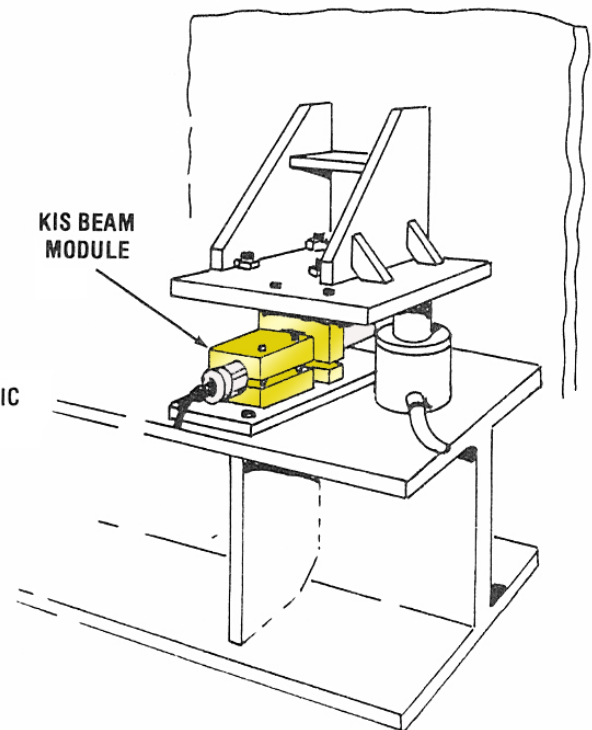
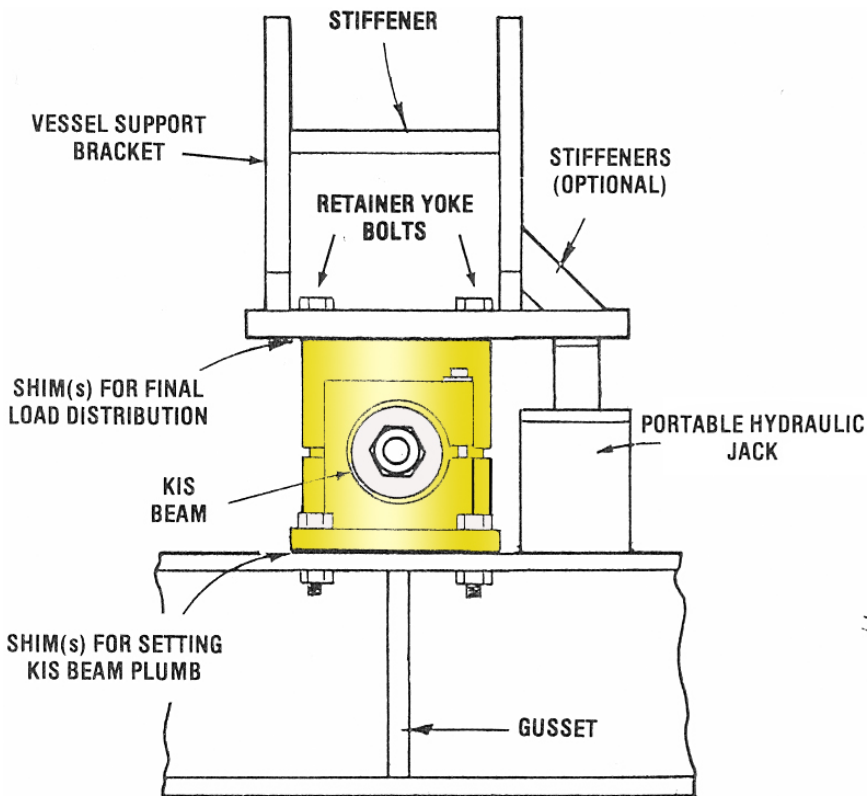

Support details - compression load cells

- Preferred stay rod arrangement
- Provision for jacking (simplifies installation, maintenance, and field calibration)
- Vertical restraint rod (used when safety check rods cannot be installed at other elevations)

Compression load cell installations typically do require stay and vertical restraint rods

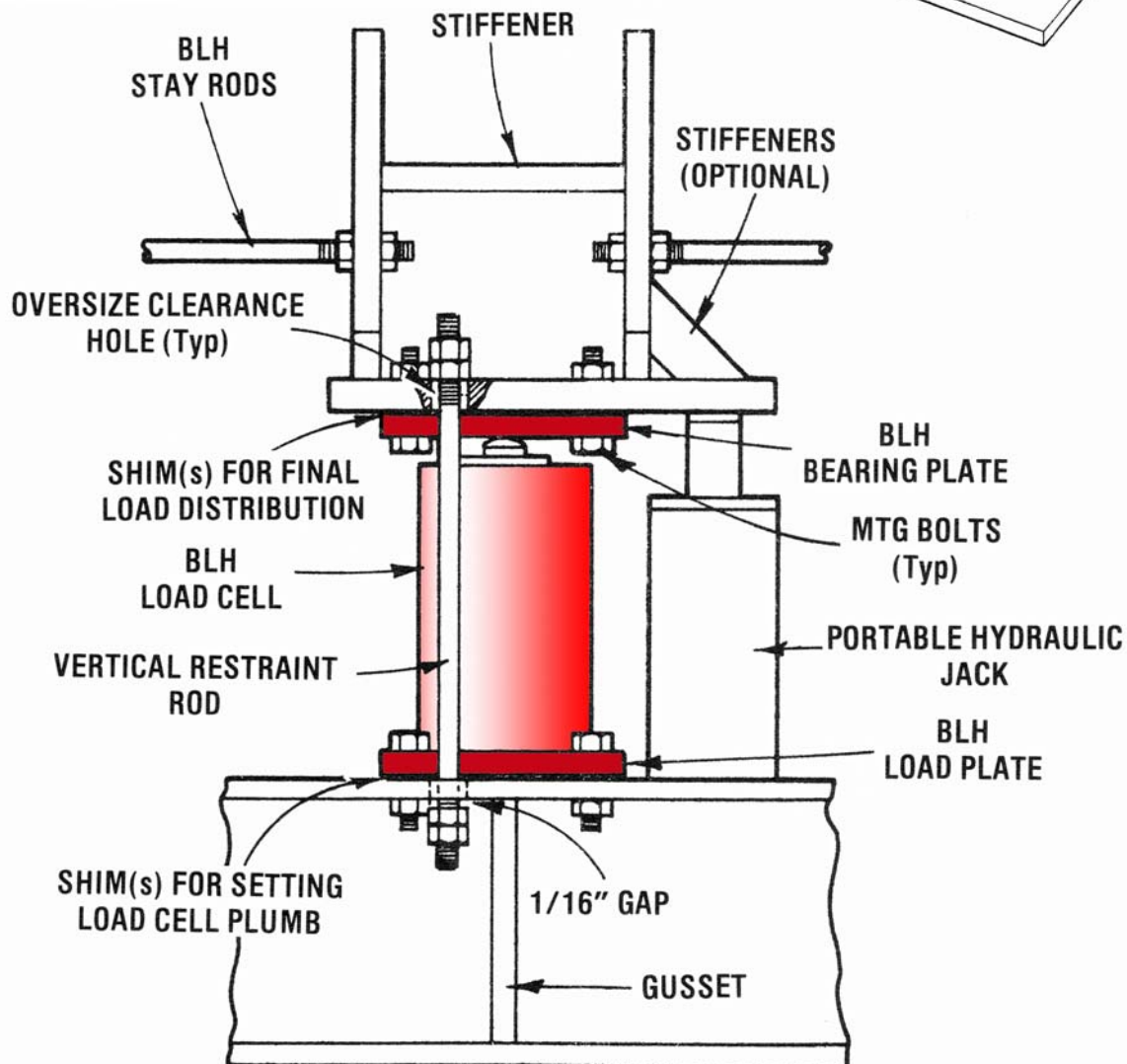
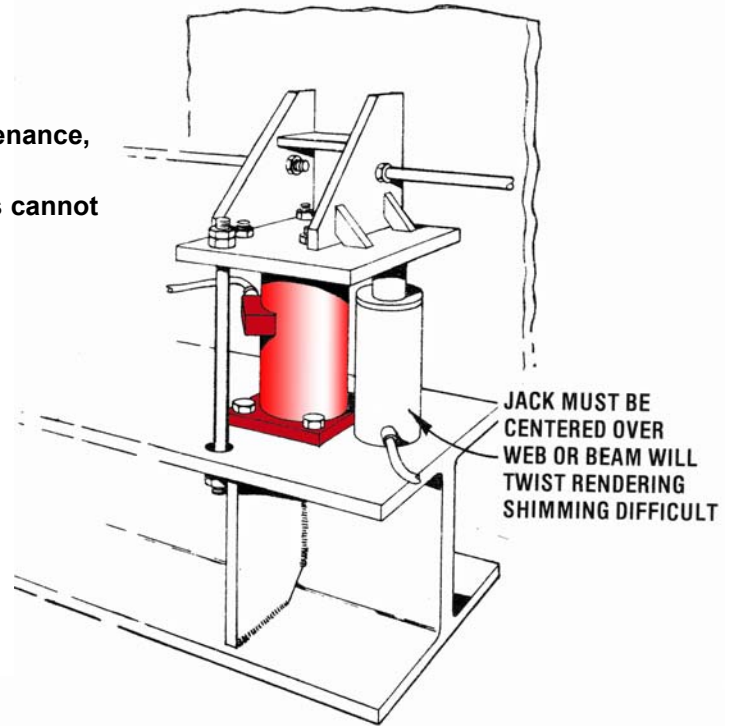

Support details - tension load or S-cells

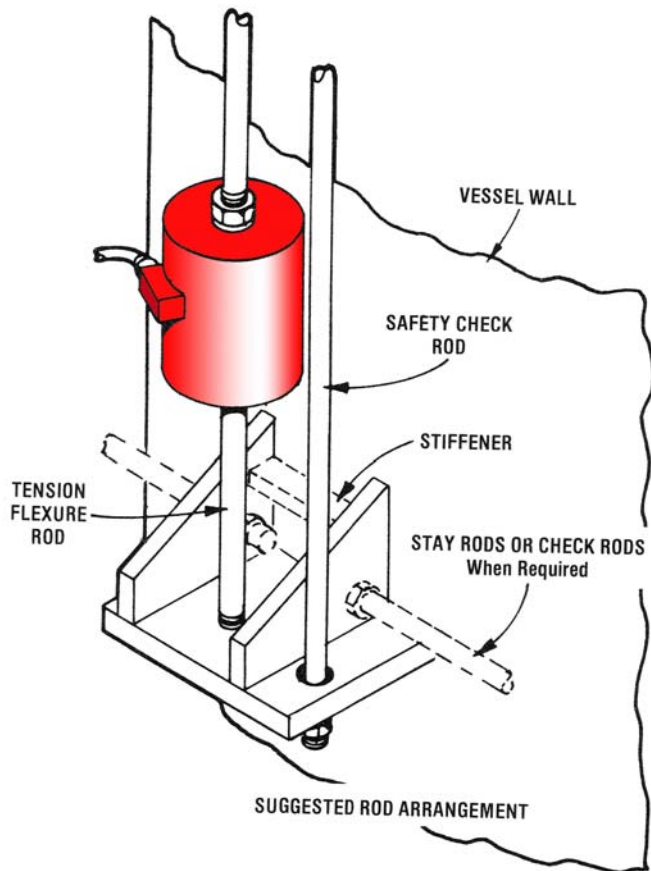

THE CHECK ROD ALSO SERVES AS AN INSTALLATION TOOL:

- Hang vessel on check rods at proper height
- Make all piping connections, weld, insulate, etc.
- Install tension cells and flexure rods, set plumb
- Back off nuts on check rod so tension cells support vessel
- Set gap on check rods and lock up nuts

A SERVICE TOOL:

- Check rods can be again used for vessel support
 - should vessel need repairs or modifications (protect tension cells from mechanical impact)
 - should tension cells ever need repairs

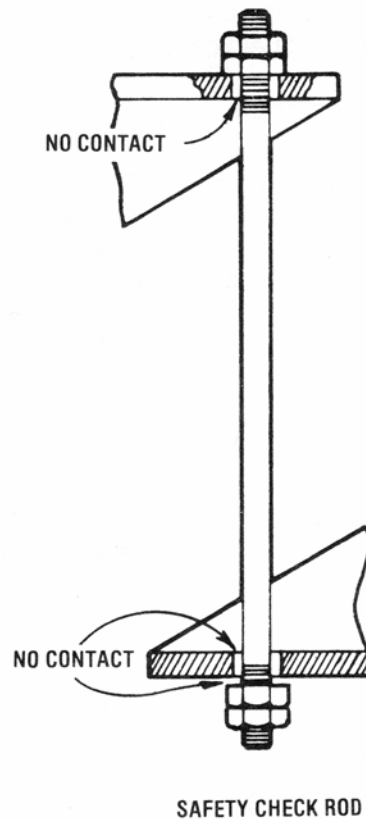
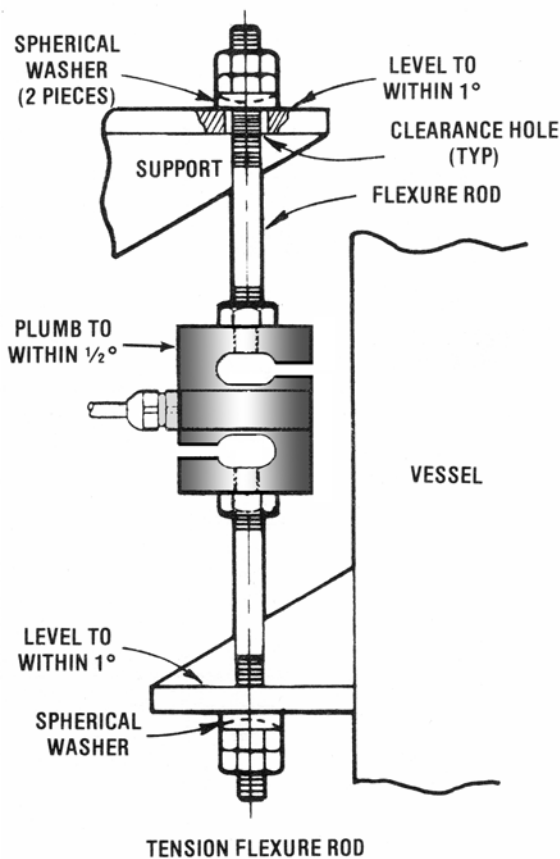

Hydraulic calibration arrangement

PREFERRED TECHNIQUE:

Calibration unit removes live load from permanent load transducer.

- **Operating procedure** Zero both systems. Fill vessel to capacity with product. Jack calibration cylinder until it carries 80% of gross weight or maximum live load. (This limit prevents gapping on the permanent load transducer.)

Bleed cylinder to reduce load on calibration cell in convenient increments. (Provide for individual operations of each cylinder since vessel weight is generally not equal on all supports and performance differs slightly among cylinders.)

- **Advantages** The effects of vessel deformation under live load - load redistribution, wall distortion, support bracket tilt, vessel elongation - will be observed and, if necessary, corrected.

No extra structural members or devices are required to support the calibration unit.

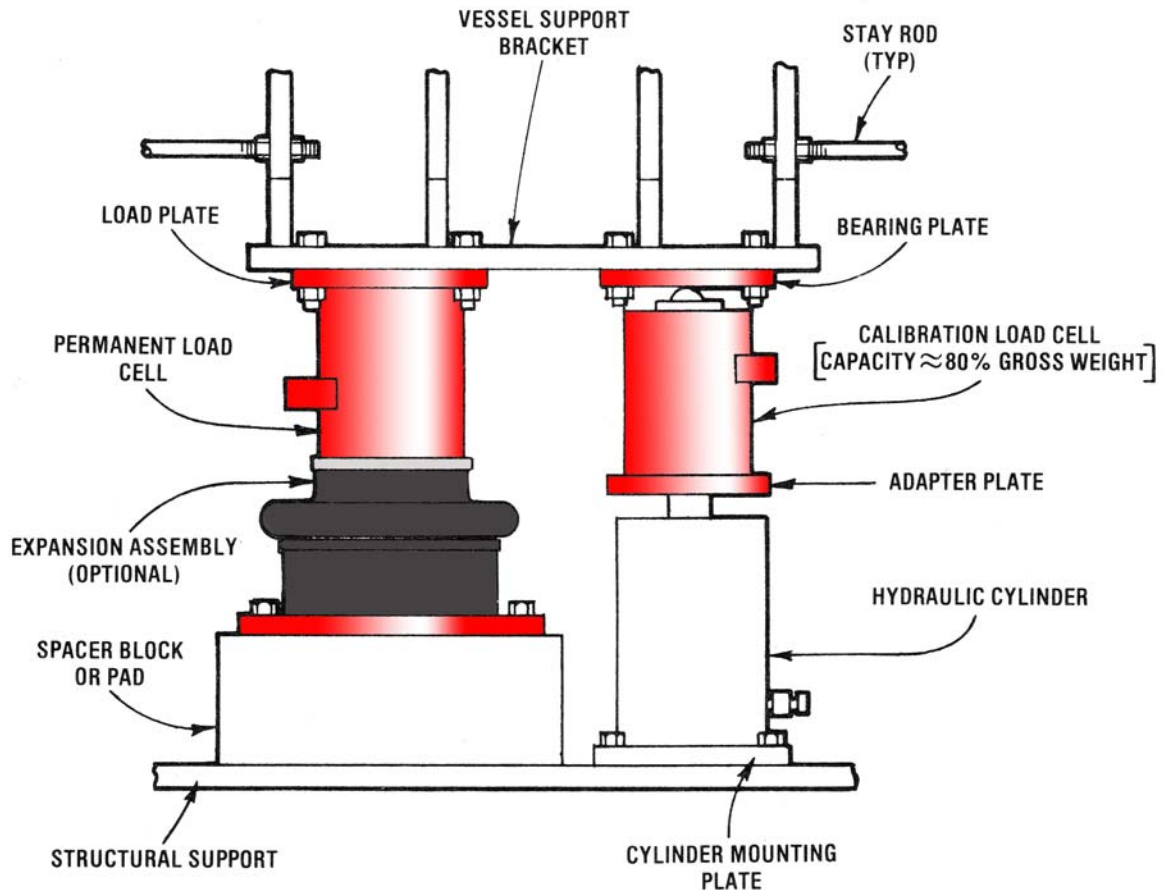
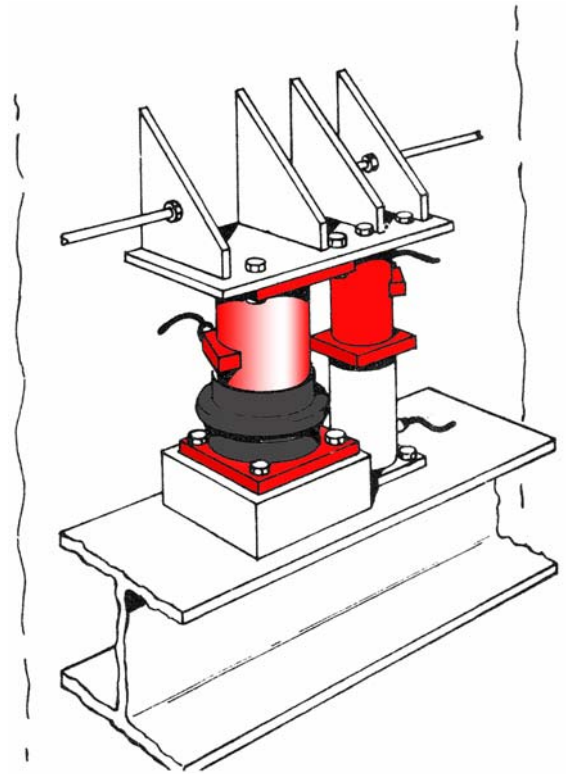

General rules. A freestanding vessel fully supported by load cells/modules on firm supports has a weigh system accuracy approaching that of the load cell/module and the instrumentation alone, a value well below 0.1 %. Experience has shown the one factor most often compromising weigh system accuracy to be the mechanical restriction arising from piping connections with insufficient flexibility or displacement capability.

To minimize these problems, Vishay BLH recommends that all piping attachments to the vessel be made as flexible as process materials and temperature will allow, specifically:

- **On high-pressure systems (> 25 psi), use schedule 10 (or 5) stainless steel pipe instead of schedule 40 carbon steel for a 150 - 300% increase in flexibility on the final run to the vessel. Filament-wound, glass-reinforced piping is suitable for applications up to 200°F and 125 psi when the process chemistry allows. Expansion joints and universal joints with adequate pressure ratings, both metallic and nonmetallic, are also recommended provided that they are positioned horizontally to avoid vertical thrust forces.**
- **On low-pressure systems (< 25 psi), use nonmetallic flexible piping devices whenever possible. Major suppliers now carry Teflon, elastomers, and plastics, all at least three times less stiff and often more wear resistant than the metallic counterparts. Be aware that metallic components covered with metal braid are sources of frictional, hysteresis-type forces due to the contact between the metal bellows and braid; in one test, a horizontally installed 2" diameter metallic expansion joint was shown to alter vessel output by 50 lbs (22.7 kg) depending upon the initial offset of the joint before the calibration run.**
- **Be careful when using forces and deflections calculated by computer for vessel and piping. Experience has shown such values to be generally oblivious to the significant vessel support and piping-support deflections encountered in the field. Refer to 'Influence of Vessel Piping and Support Deflection' (page 29) for often ignored deflection sources.**
- **Support the piping from the same floor the vessel rests upon; do this at least for the support closest to the vessel. This tends to minimize differential thermal expansion and differential support (floor-to-floor) deflection problems between piping and vessel. Refer to Special Design Considerations, "Piping Flexibility", for supportive discussions.**
- **For minimum piping restriction, consider cold springing all piping at fit up so that the mating flanges on piping and vessel align freely before being bolted together. This would be particularly beneficial on lighter weigh vessels.**

VISHAY'S LAW:
all piping attachments
to the vessel must be as
flexible as process
materials and
temperature will allow

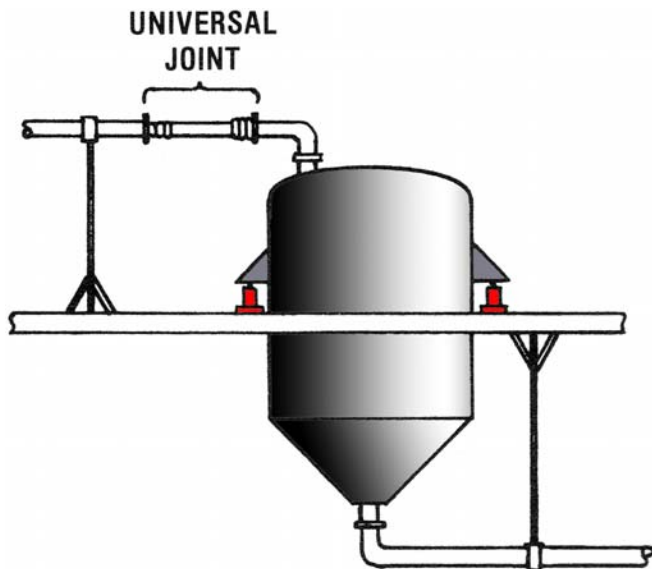

**RECOMMENDED PIPE
SUPPORT ARRANGEMENT**

General rules (continued)

- All piping tends to sag from its theoretical (design) position due to its own dead weight, exterior insulation, and live contents. It is therefore good practice to inspect all piping runs between weigh vessel and first pipe support for adequate clearance around each line; a minimum space of 1 inch (25.4 mm) should exist between any given pipe and another pipe, steelwork, ductwork, etc. All too often, field installation crews fitting and insulating pipes violate the intended spatial geometries leaving only narrow gaps between lines which become sources for nonlinear mechanical restriction to the weigh vessel.

Sealed systems

FLEXIBLE PIPING DEVICES (Expansion joints, universal joints, flexible couplings; flexible hoses and ducts)

- Locate these devices in horizontal piping runs adjacent to the weigh vessel to avoid vertical thrust forces from varying internal pressures associated with material flow and process chemistry. It is preferable to have these forces act laterally where they translate into minor horizontal forces and insignificant overturning moments on the vessel.
- Do not stretch or compress these units excessively or use them to compensate for initial piping misalignment at fit up, lest their stiffness characteristics be altered. Above all, if flexible devices are used vertically, do not rest the vessel upon them and then install the primary vessel supports with the vessel in that position ... this field installation practice is not uncommon on smaller vessels. Obviously, a corrugated device will lose much of its flexibility when tightly compressed.
- Where large displacements must be accommodated with low force, use hose for the final leg to the vessel. If this is not practical, consider using two expansion joints or flexible couplings in a series as a “universal joint”, or a flexible hose bent U-shaped as a “traveling hose”. This is particularly important for low capacity systems where even small piping forces will disturb weigh system stability.
- Do not use rigid insulation on expansion joints and flexible hoses or their lateral flexibility will be compromised; use heat-trace cable instead.

It is good practice to inspect all piping runs between weigh vessel and first pipe support for adequate clearance around each line

Sealed systems (continued)

FLEXIBLE PIPING DEVICES (Expansion joints, universal joints, flexible couplings; flexible hoses and ducts)

- In some systems, process pressure is high enough to force expansion joint flanges tight against limit bolts (supplied for that purpose). If joint length is short compared to diameter, perhaps 1:1 or less, joint flexibility may be compromised by friction of bolts against flanges. Lateral flexibility may be restored, however, if limit bolts are replaced with properly terminated steel cable of equivalent tensile strength. This “fix” should not be necessary in a properly designed system; it is mentioned here as a means of improving the flexibility of existing piping in a retrofit installation.

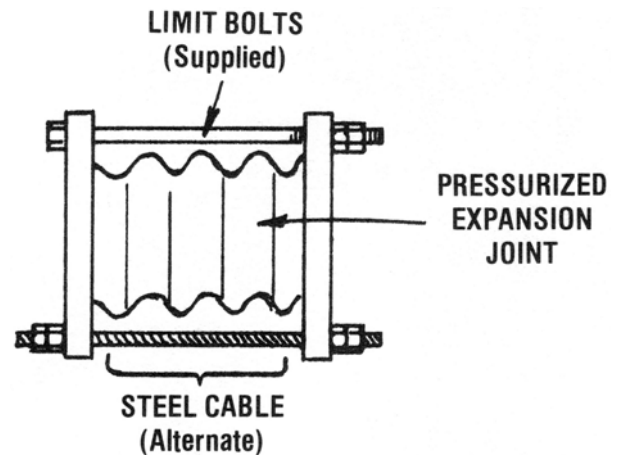

- A more frequent problem occurs when short flexible devices absorb the torque acting about the pipe axis and “wind up” until the limit bolts jam tight. The resultant loss of flexibility may impair weigh system accuracy particularly if dead weight calibration had been performed with the system cold, before the pipe rotation occurred. If possible, install a pipe guide ahead of the flexible joint to arrest the rotation. Failing that, a simpler “fix” may be to loosen the bolts. This will reduce the stiffness somewhat, but not entirely, due to the continued torque imposed on the joint.

- Flexible devices of nonmetallic materials offer more flexibility in less space and with less vibration transmission than metal counterparts. These benefits plus, variously, increased wear, corrosion and fatigue resistance makes non-metallic highly attractive when the process pressure and temperature requirements can be met.

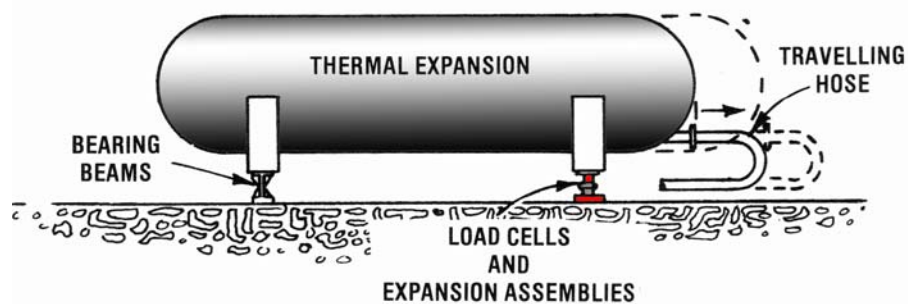
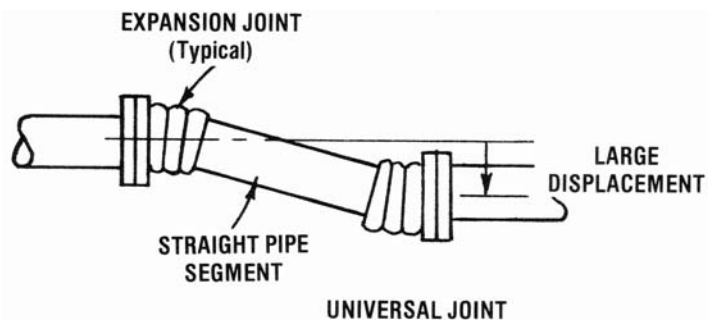

Sealed systems (continued)

HORIZONTAL TANKS ON LOAD CELLS/MODULES AND BEARING BEAMS

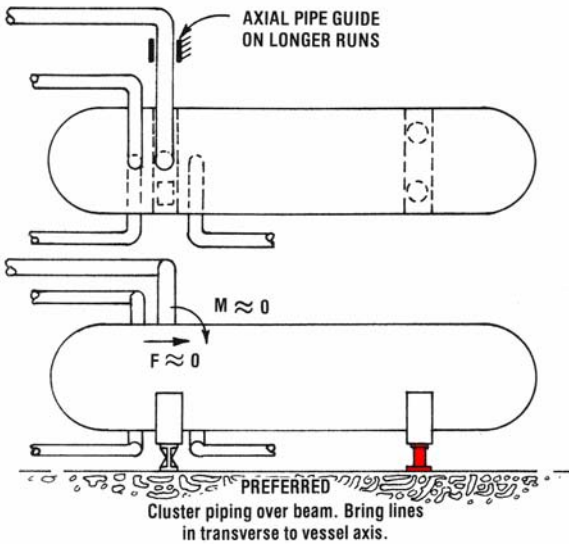

- Locate as many of the piping attachments as practical in the vicinity of the bearing beam. This minimizes the vertical piping forces seen by the load cells/modules, since pipes then act over the fulcrum of the vessel.
- Orient last piping runs transverse to vessel to minimize effect of piping expansion on the weigh system. Expansion forces will then tend to cause minor overturning moments about the tank axis with little effect on weigh system output.

VENT (BLOW DOWN) LINES

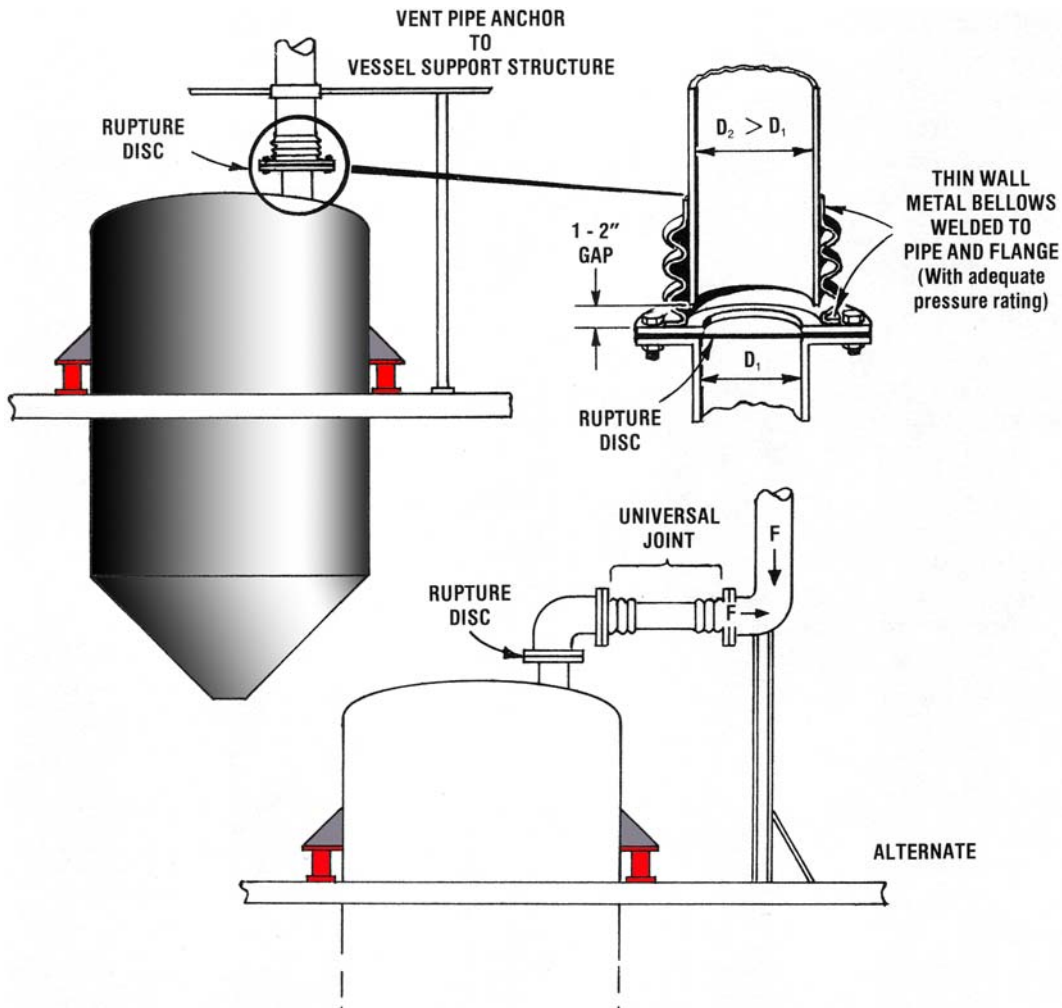

Vented systems

ATTACHMENT DETAILS:

Achieve maximum weigh system accuracy by eliminating piping interactions entirely ... feed piping through clearance ports in the vessel, covering gaps with very flexible dust boots. Support all such piping from structure just beyond the vessel.

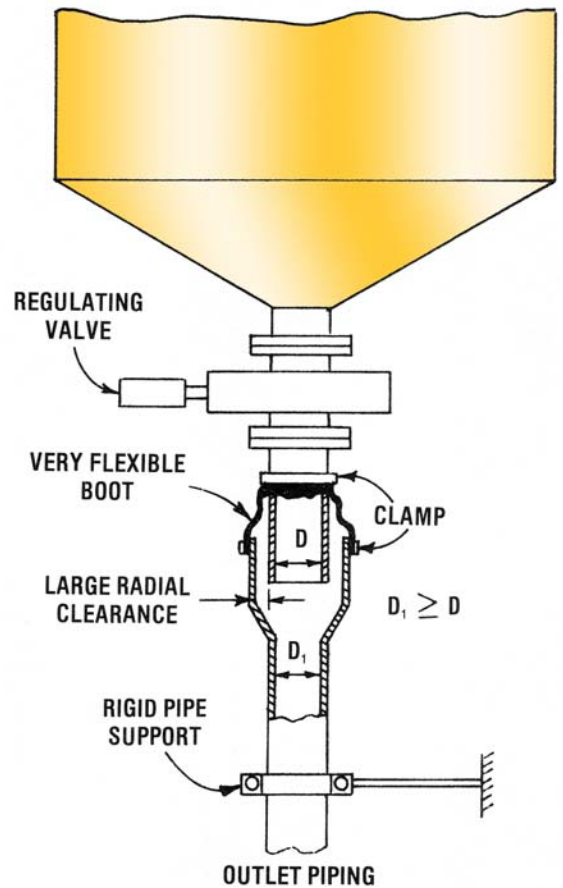
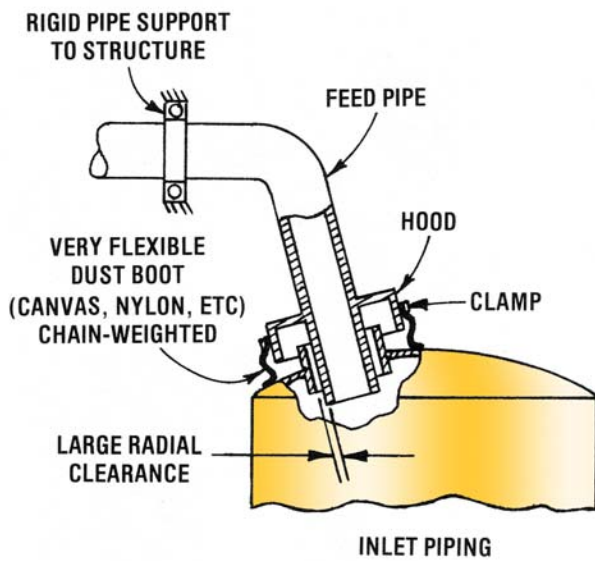

Vessel design significantly affects the overall functionality of every process weighing system. This chapter presents field proven design strategies that optimize weigh system performance.

Vessel support brackets

Locate support brackets at the maximum vessel center-of-gravity elevation whenever convenient. The vessel is then inherently stable and the need for lateral restraints away from the plane of support (i.e., safety check rods) is minimized.

Restrict angular deformation of the support bracket under gross vessel weight to less than $\frac{1}{2}^\circ$ when a compression load cell or module is mounted on the vessel bracket, less than 2° when mating accessory is mounted on the bracket, to avoid compromising system accuracy. (Brackets on unweighed vessels are usually bolted down, so designing a vessel wall for stiffness to minimize local bracket deflection is not normally considered; now it should be.)

Design the support brackets to accommodate some means of jacking the vessel to ease load cell installation and maintenance. Refer to 'Structural Design' for design suggestions.

Do not position the brackets so that load cell installation and maintenance is impeded by concrete or limited access space with attendant loss of time and increased expense.

Process heating systems

Do not use steam or heated gas in a jacketed vessel when hot oil or water will do, and avoid the adverse effect of variable buoyancy with temperature and pressure on in-process system accuracy.

Vessels with agitators

When the weight of an agitator motor and mount is an appreciable portion of the gross vessel weight, locate the apparatus on the vessel for the most uniform weight distribution among the supporting load cells/modules. This not only facilitates vessel handling and reduces the overload hazard to one or two cells, but also permits the use of lower capacity load cells/modules (with more signal output) for better weigh system resolution.

The stability of the weigh system will be enhanced if internal baffles or counter-rotating agitator blades are used to reduce fluid slosh.

Design the support brackets to accommodate some means of jacking the vessel to ease load cell/module installation, dummy beam replacement, and routine maintenance

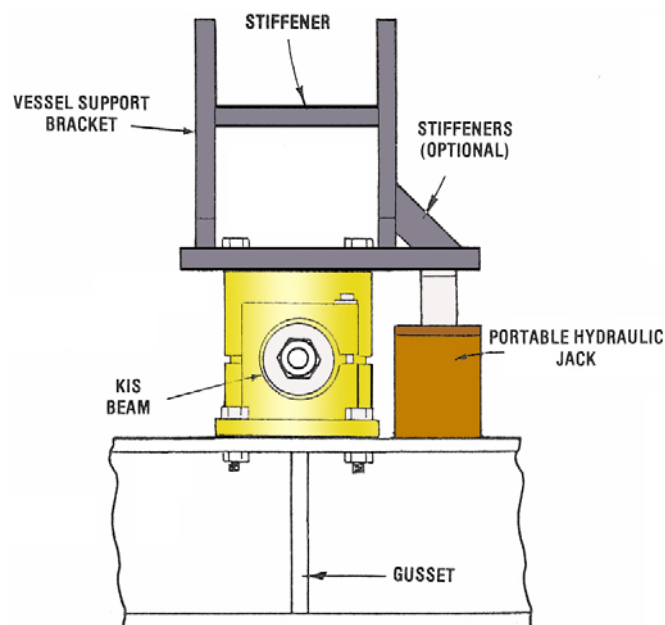

Align lifting lugs with the load cell positions, so that tipping of the vessel is precluded

Lifting lugs for calibration weights

Specify weight lifting lugs on those vessels requiring periodic dead weight calibration. Locate one lug per load cell/module near the base of the vessel to accommodate the jacking device (chain fall and come-along) and dead weight blocks. Position the lugs symmetrically around the vessel perimeter while maintaining adequate clearances from the surrounding equipment for jacking weights. A common arrangement is to align the lugs with the load cell/module positions, so that tipping of the vessel is precluded - a real possibility on smaller vessels with three supports or less.

Design the lugs to carry 10% of gross vessel weight when the dead weight/material substitution method is to be used; design the lugs for their share of the total live load if calibration is by dead weights alone.

Saddle supports for horizontal tanks on load cells and bearing beams

For maximum weigh system accuracy when mechanical field calibration will not be used, position supports symmetrically on the tank so that the approximate load fraction seen by the load cells/modules is known and will not change with load.

Vessel tare-to-live weight ratio

Minimize the ratio of tare weight to live weight for the most stable signal. As indicated earlier, the general rule of thumb for selection of load cell/module capacity is to obtain 1.0 mV/V output over the range of live load. In most installations, this is assured since the vessel tare weight is perhaps 10% - 30% of the gross weight; a load cell/module with 2.0 mV/V output will easily provide the necessary signal for a high accuracy system. On the other hand, a system consisting of a thermally jacketed, agitated and nonsymmetric vessel weighing some 5000 pounds with rigid jacketed piping connections cannot sense a 300 pound live load with great precision; the 'live' signal must be amplified to the point where line noise and normally trivial temperature effects now become significant. Consult Vishay BLH for recommendations if a high tare weight appears inevitable, since electronic techniques can be employed to increase system accuracy at low signal levels.

Vessels with non-level material

Design inlet and outlet ports for symmetric loading and unloading of material. Doing so aids weigh system accuracy by keeping the load on the cells uniform and, therefore, the support deflections more uniform. The former minimizes the already-small error due to variation in load cell/module characteristics; the latter reduces the likelihood of mechanical restrictions due to vessel tilt.

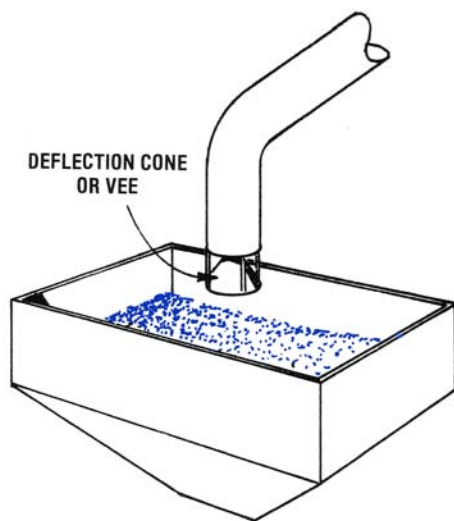
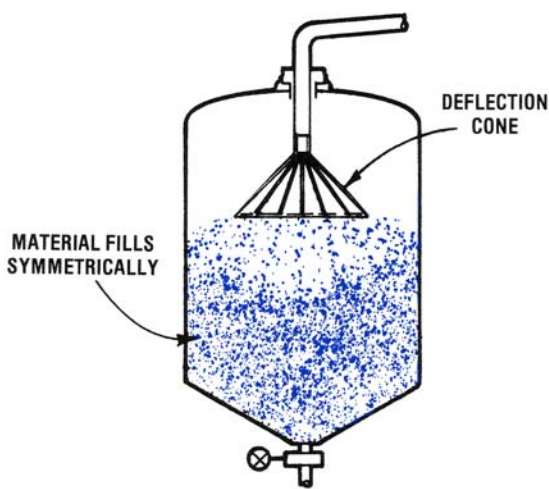

Inlet ports designed for symmetric loading

Vessels suspended by single tension cell

If lateral restraints are not present on the weigh vessel, one or more swivels should be included in the tension linkage to accommodate the modest vessel rotation that usually occurs without applying a torsional moment to the tension cell. Torque on the tension cell will produce a small, but variable error in the system readout.

Experience has shown that most system designers do not properly size the support structure to keep the vessel deflection at gross weight under $\frac{1}{16}$ ". Ignoring this will probably generate several deflection-induced problems.

Vessels located in traffic areas

It is good practice to construct protective piers or barriers on the traffic side of weigh vessel supports to preclude system shutdown, however temporary, from accidental impact.



Improper wiring details can sometimes generate mechanical restrictions to the weigh vessel or cause system calibration errors. Adherence to the following should avoid such problems.

Flexible conduit

Use flexible conduit between the moving load transducer (or vessel) and the stationary support structure. It is good practice to provide a drip leg to prevent moisture or chemical accumulation at cable entry or conductor, particularly in wash down areas or outdoor installations. To prevent flexible conduit from being stretched taught by the installation crew with attendant loss of flexibility, specify a 360° loop in the conduit.

It is good practice to provide a drip leg to prevent moisture or chemical accumulation at cable entry or conductor

Do not shorten the load cell/weigh module cable

Do not shorten the load cell/module cable. This practice needlessly alters system calibration. Instead, coil the excess outside the summing junction box, or where conduit is required, inside the summing box or inside an otherwise empty box adjacent to it. When longer cable lengths are required, order additional extension junction boxes and the necessary length of four-conductor cable. Increasing cable length on individual load cells up to 25 feet (7.62 m) will not add significant error to the system.

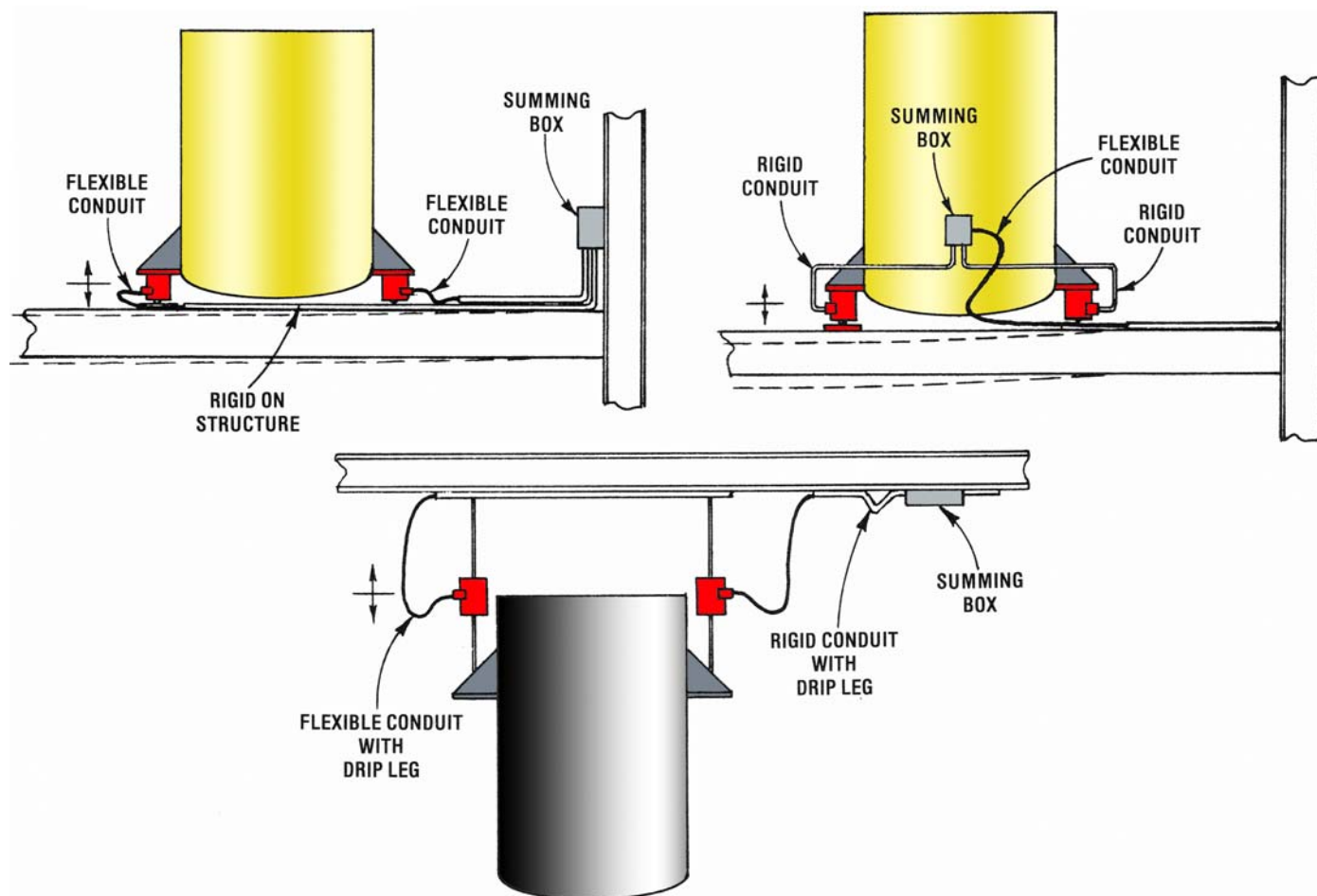

Do not shorten the load cell/weigh module cable (continued)

Where cables must be lengthened to fit, load cell output will be altered. It will decrease by 0.03% (0.1 ohm/350 ohms) for every ten feet of cable added when the load cell is operating at a constant 70°F. As the operating temperature rises above 70°, load cell output will decrease further by 0.006%/100°F for every ten feet added. These known (not random) errors in individual load transducers are additive in their total affect upon the weigh system.

Where cables must be lengthened to fit, load cell output will be altered

Example 1 a: Four load cells/modules are ordered with standard 10 feet of integral cable. Two cables are subsequently lengthened five feet apiece. The load transducers operate at the constant ambient temperature of 70°F.

Error Analysis: If weigh vessel is to be dead weight calibrated, no system errors result from modifying the cable. If weigh vessel is to be calibrated electronically, or not at all, system output will be reduced by 0.015% in both cells/modules for a total span loss of 0.030%. The readout instrument may be adjusted by this amount to compensate.

Example 1 b: Assume that ambient temperature surrounding the above cells/modules cycles between 70°F and 120°F.

Error Analysis: In addition to errors discussed in Example 1 a, the output of both cells/modules with lengthened 15 foot cables will decrease 0.0015% apiece, for a total system readout error of 0.003% at 120°F. For most systems this error is insignificant.

Lateral restraints - stay rods, safety check rods

LATERAL RESTRAINTS are mechanical devices designed to secure a weigh vessel to the structure, thereby maintaining initial alignment throughout service life. Unlike unweighed vessels with support brackets that may be bolted or welded directly to the structure, weigh vessels mount on load cells that provide only vertical reactions at one point under the support bracket; while there is some restraint available through friction, employing it would be detrimental to weigh system accuracy. So, with few exceptions, it is advisable to apply some form of restraints to all weigh vessels for reasons of...

SAFETY

Attached piping can be fatigued or ruptured, or vessels can be upset by unrestrained vessel motion in response to a number of forces prevalent at industrial sites. Systems containing hazardous materials are of particular concern.

WEIGH SYSTEM ACCURACY AND STABILITY

Vessel translation, vibration, or oscillation must be properly controlled or system calibration accuracy and stability cannot be maintained. For example, vessel translation can apply sideloads on the transducers causing readout errors; vessels vibration and oscillation generate variable signals, which may impair the system response or control functions.

PARTIAL LISTING OF OPERATIONAL AND ENVIRONMENTAL ELEMENTS ACTING TO DISTURB A VESSEL...

INTERNAL TO VESSEL:

- Fluid sloshing
- Violent chemical reactions
- Material entry and exit (thrust and impact forces due to mass flow)

EXTERNAL TO VESSEL

- Vibrators or live bottoms agitators
- Thermal expansion of attached piping structural support vibration from rotating equipment or traffic
- Structural support deflection from adjacent vessels, equipment or traffic
- Potential impact from traffic or overhead crane
- Wind
- Seismic events
- Other expected events

Free standing load cell installations typically require mechanical devices designed to secure the weigh vessel to the structure

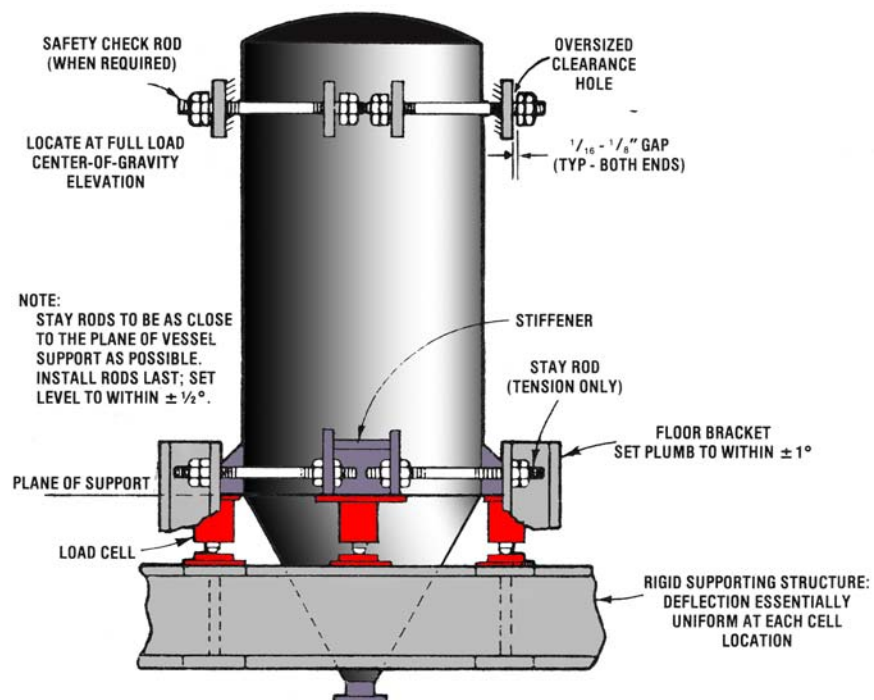

Lateral restraints - stay rods, safety check rods (continued)

STAY RODS, SAFETY CHECK RODS

Experience has shown the use of tension straps to be a simple, but effective, means to vessel restraint. In the usual configuration, straps are arranged in pairs - one pair for each load cell on the vessel, positioned symmetrically about, and tangential to, the vessel. Vishay BLH defines two categories of tension straps...

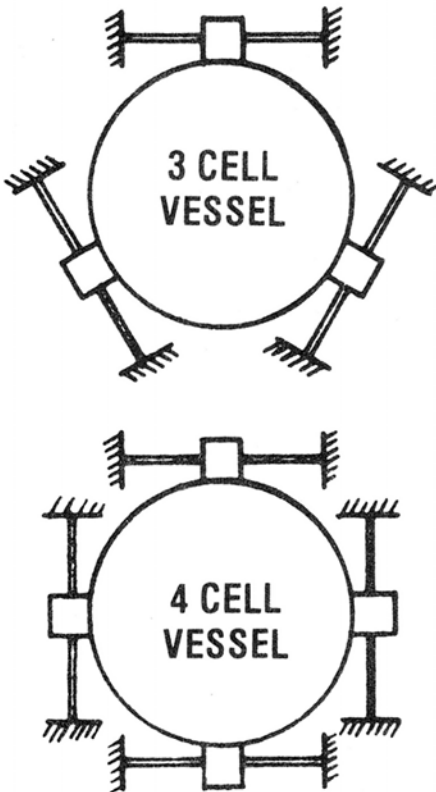

Lateral restraints on three and four cell vessels

STAY RODS constitute the primary lateral restraint system on most vessels and are intended to rigidly constrain or “stay” the vessel. These rods are installed snug tight between a gusset on the vessel support bracket and a rigid floor bracket a few feet away. Vessel translation or rotation is thus restricted, while radial thermal expansion is relatively unimpeded. Because stay rods are snug to the vessel, they are an active part of the weigh system and must be installed level to ensure a linear response with deflection. Rules for sizing stay rods are presented in the BLH publication entitled ‘TECHNICAL DATA/ Sizing of Lateral Restraints’ (TD 068).

SAFETY CHECK RODS are backup members whose sole function is to hold the vessel in “check”, preventing gross tipping or wobbling. These straps are installed with a loose fit so that they do not interact with the weigh vessel even after thermal growth, but simply contribute to the vessel tare weight. Safety check rods may be positioned at vessel elevations other than the plane of support to guarantee stability for those vessels with large height-to-width ratios, such as tall storage silos.

STAY ROD installation considerations: By terminating the rods at brackets adjacent to the vessel and separate from the building structure, the rod end deflection is effectively limited to the load cell compression (0.010") or tension linkage elongation (0.030") rather than the much greater overall floor deflection between the vessel and structure. The likelihood of significant mechanical restriction arising from stay rods is greatly reduced. The majority of vessels have support brackets located near the maximum center-of-gravity elevation; many of the disturbing forces (e.g., seismic or wind) act at or near this location. In this case, installation of the rods at the brackets removes these forces at the point of application leaving the vessel relatively unloaded.

By terminating the rods at a gusset plate on the vessel support bracket, a separate reinforced attachment area on the vessel wall and a separate stay rod fitting are avoided; thermal expansion between the plane of support and rod attachment point becomes trivial; and the restraint may be located outside the vessel insulation, simplifying installation.

Lateral restraints - stay rods, safety check rods (continued)

LATERAL RESTRAINTS are not necessary for vessels that meet all requirements listed:

- **Essentially static contents; no significant agitation or vibration.**
- **Essentially static environment; no possibility of large external forces such as wind, excessive support structure vibration, wayward forklift, or seismic event (seismic zones 0 to 1 only).**
- **Three or more supports.**
- **Plane of support is near maximum center-of-gravity (CG) elevation.**
- **Either no direct piping contact (vented systems) or only very flexible nonmetallic connections (sealed systems).** Refer to "Piping Design" section for suggestions.
- **Slow material flow rates (sealed systems).**
- **Mounted in tension or rest on fixed mounting plates.**

Lateral restraints are not necessary for vessels that have static contents with no significant agitation or vibration

OBSERVATION:

Should minor disturbances be present or expected, safety check rods or some form of bumper may be added to preclude large vessel motion. This is possible only for vessels that will return to their original position after the disturbance is over; e.g., vessels supported in tension or compression at or above their maximum CG elevation.

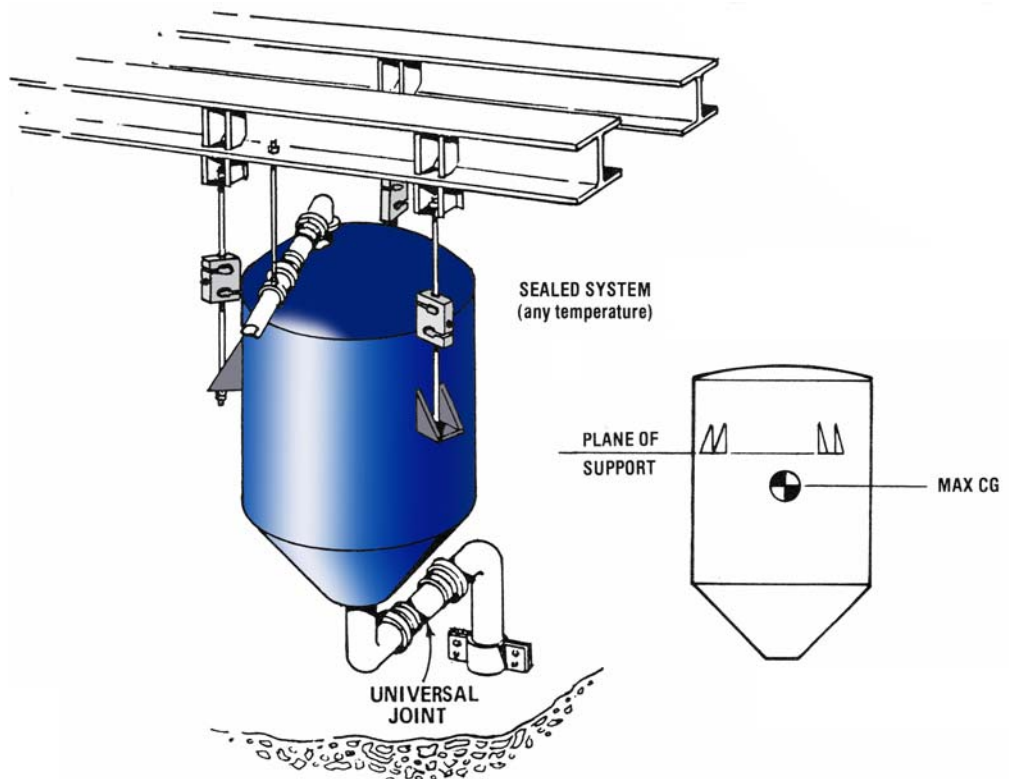

Lateral restraints - stay rods, safety check rods (continued)

LATERAL RESTRAINTS not necessary for vessels meeting all requirements listed on the previous page.

LATERAL RESTRAINTS are essential for vessels subjected to one or more of the following:

- **Low friction expansion assemblies are used; restraints required to maintain initial vessel alignment.**
- **Very active contents; sloshing or violent chemical reaction.**
- **Active environment; wind, structural vibration, vehicle threat, or high seismic activity zone (Zone 2 or 3).**
- **Large agitator or vibrator (Refer to "Special Applications" section for suggestions on vessels with vibrators).**
- **Plane of support well away from maximum center-of gravity (CG) elevation.**
- **Top heavy or heavy off-centered auxiliary equipment.**

OBSERVATION:

When the significance of disturbing forces is uncertain, it is good practice to design the restraint system, provide attachment points on the vessel, and then see how the vessel functions in operation. If restraints are required, the space should be available and the restraints can then be added.

When the significance of disturbing forces is uncertain, it is good practice to design the restraint system

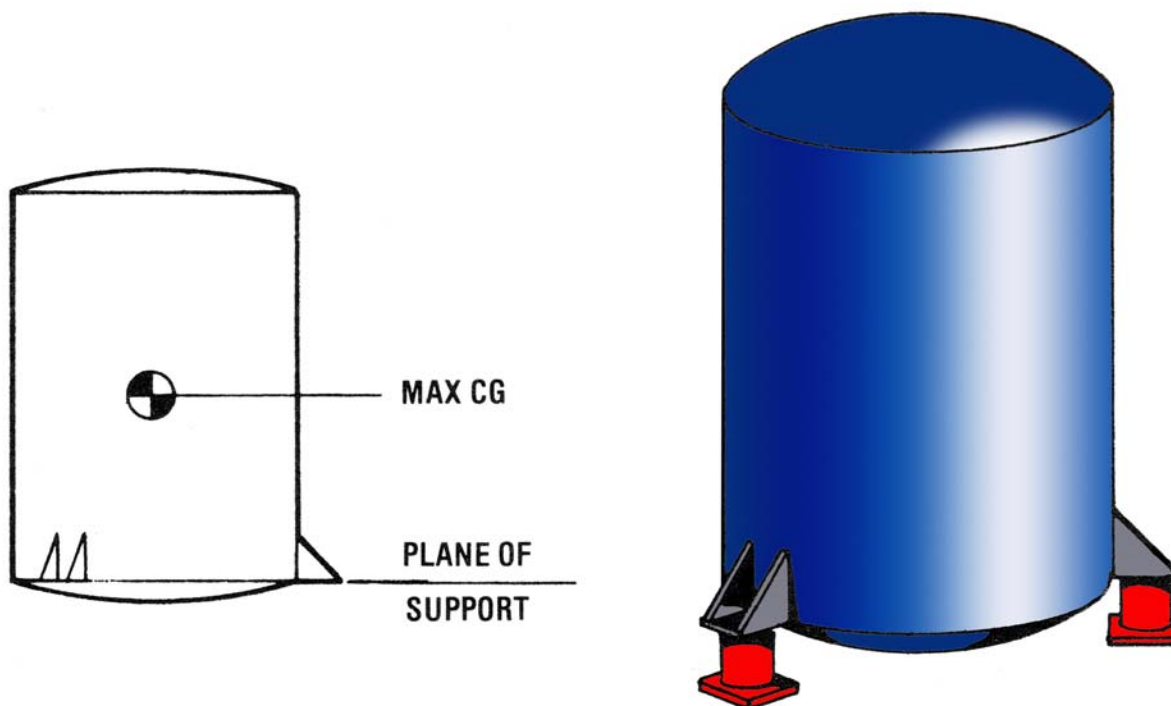

Special Case: Vessel center-of-gravity above plane of support storage vessel off in a corner, totally undisturbed, contents nonhazardous.

**Lateral restraints - stay rods, safety check rods
(continued)**

LATERAL RESTRAINTS are necessary for vessels meeting any of the conditions depicted on this page.

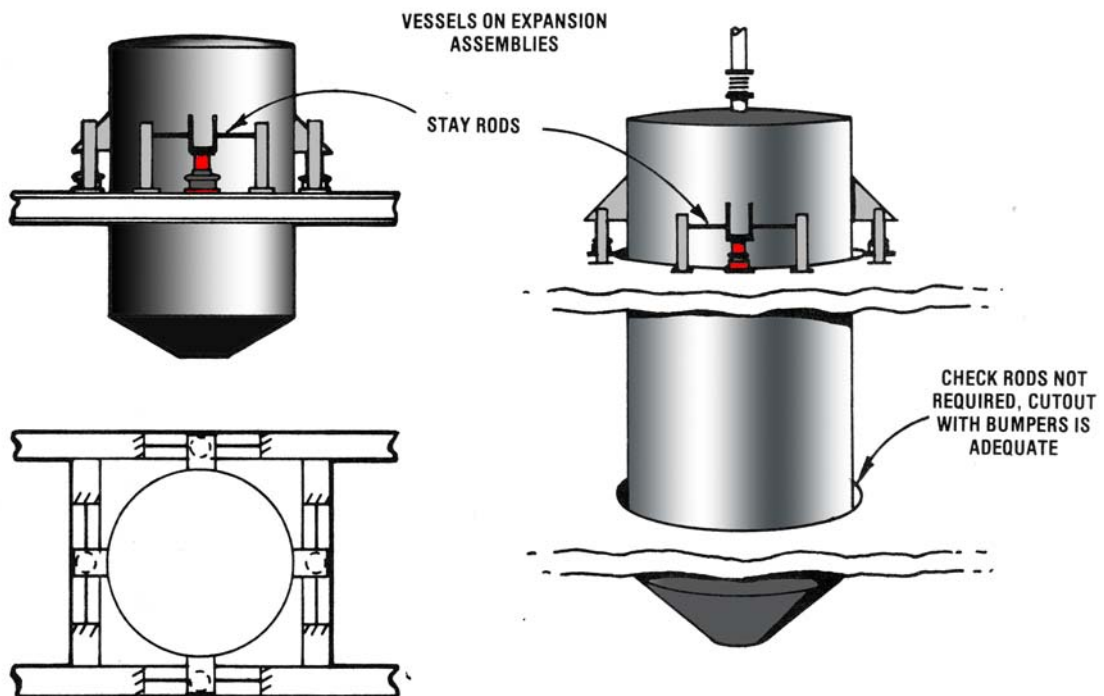
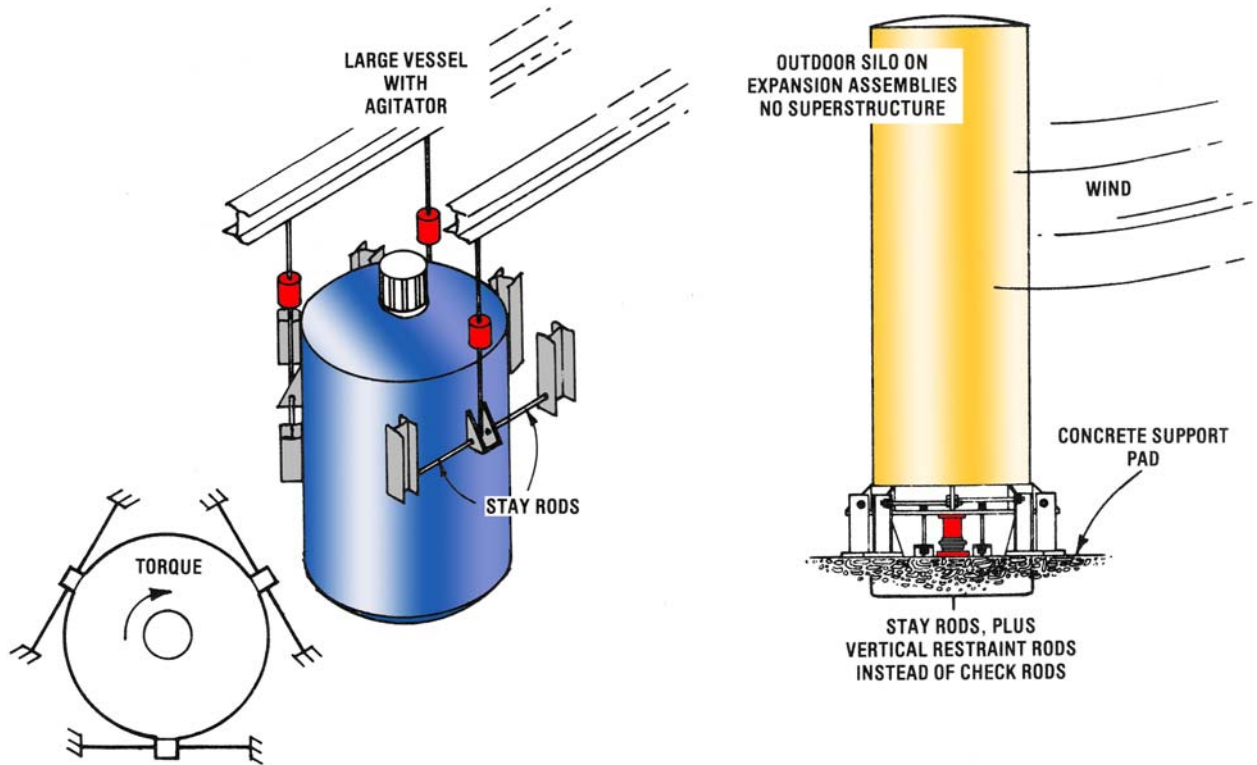

Lateral restraints - stay rods, safety check rods (continued)

LATERAL RESTRAINTS are necessary for vessels meeting any of the conditions depicted on this page.

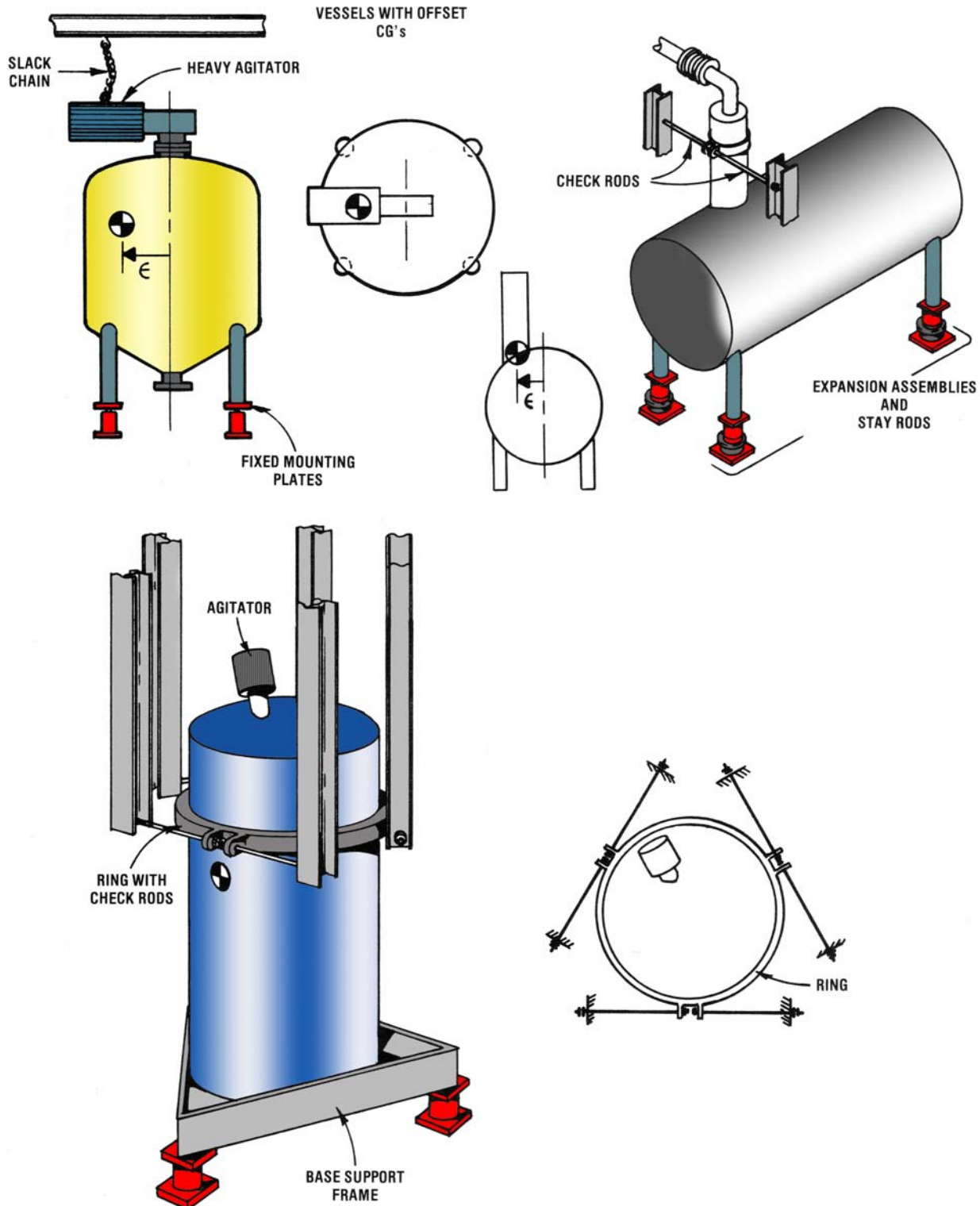

Lateral restraints - stay rods, safety check rods (continued)

LATERAL RESTRAINTS are necessary for vessels meeting any of the conditions depicted on this page.

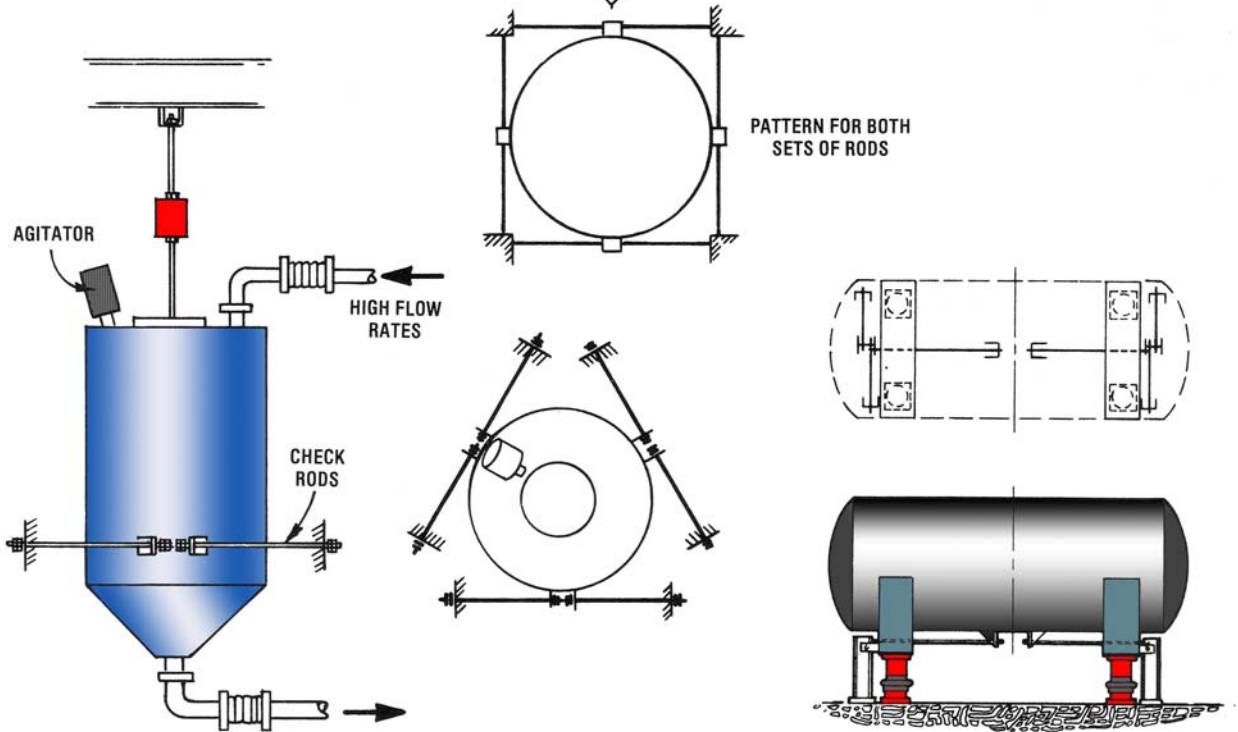
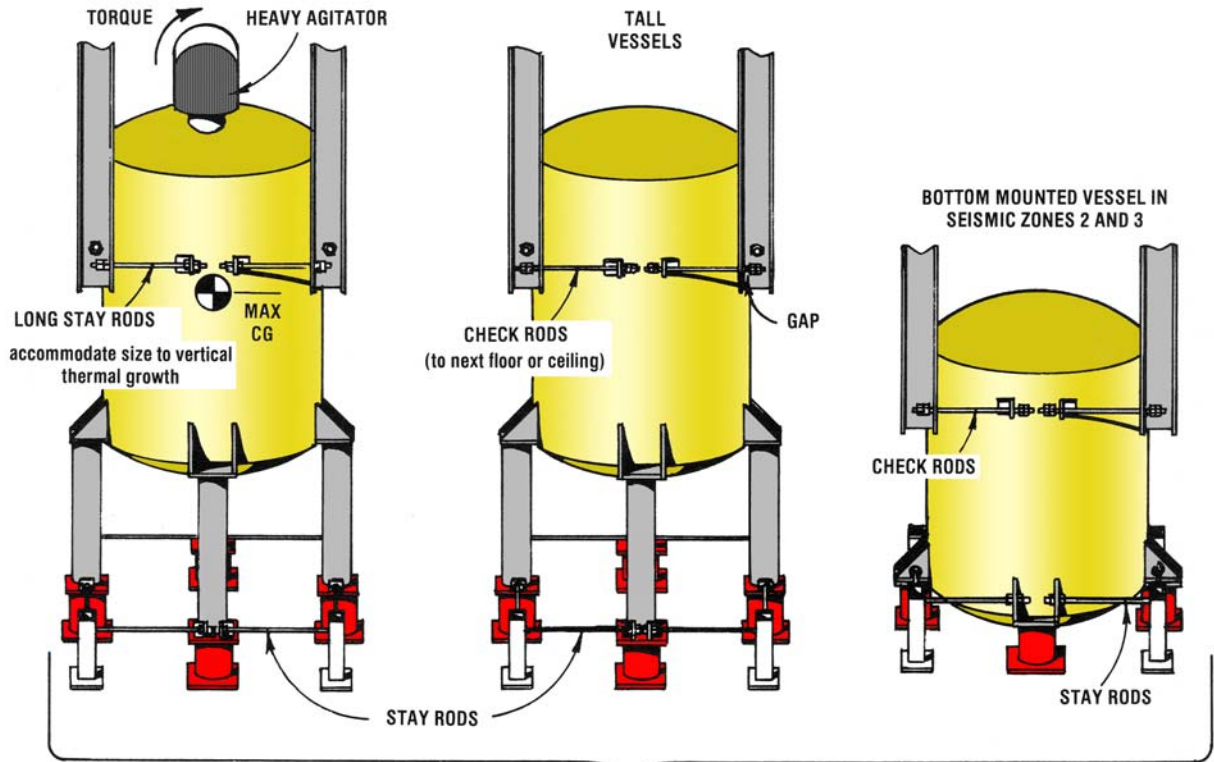

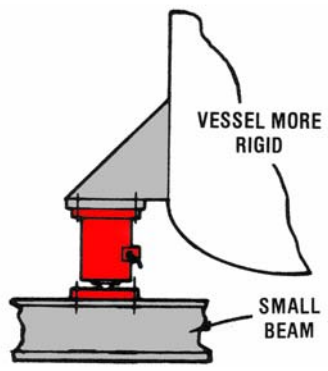
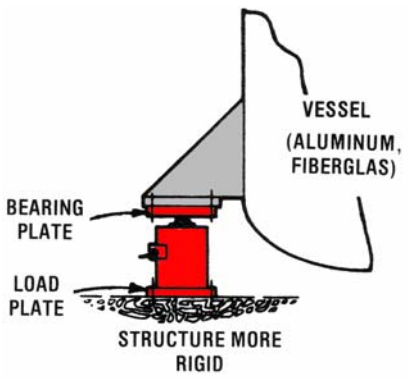

Fixed mounting plates: standard mounting kit when vessel and support structure are both at ambient temperature

Accessory selection and installation

Load cells in compression

General rule for compression use:
 Attach load cell to whichever surface is more rigid, the vessel support bracket or supporting structure. The load cell should not deviate from initial plumb during service, or calibration accuracy may be compromised. When the choice is not apparent, mount load cell with load button down.

Expansion assembly:

Accommodates thermal expansion or contraction of a vessel relative to support structure with minimum side loading of load cell. Generally necessary outdoors and indoors when vessel temperature differs from ambient. The load cell is usually installed with load button down for convenience.

Thermal insulation pad:

Reduces heat conduction from heated vessel to load cell allowing load cell temperature to remain close to ambient; temperature effects on performance are thus minimized and calibration accuracy is preserved. The pad is made of a rigid glass-cloth laminate with extremely low thermal conductivity.

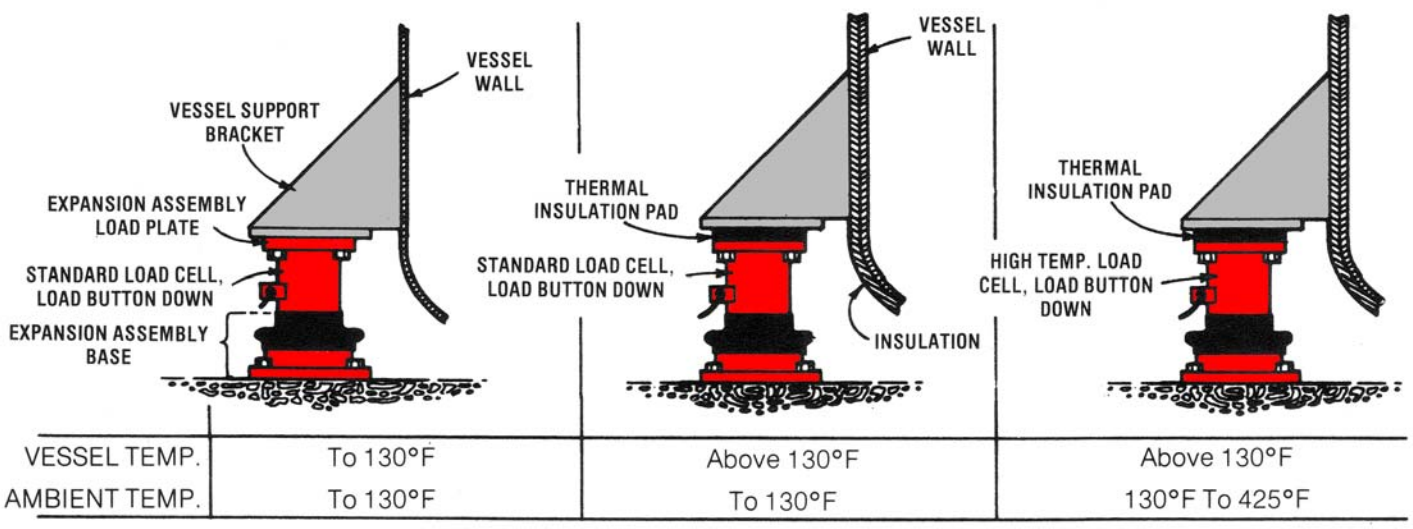

Thermal expansion and contraction accessories

Accessory selection and installation

Load cells in compression (continued)

INSTALLATION TOOLS

These “simulated” assemblies (aka dummy beams), duplicate the critical dimensions of the corresponding load cells and accessories for use in place of load cells during vessel installation. Eliminates risk of damage to precision load cells due to stray welding currents and mechanical impact.

HOW TO USE

- Order simulated assemblies when placing load cell order for delivery in advance of load cells.
- Install simulated assemblies; make all piping connections, weld, insulate, etc.
- When vessel work is complete, jack each vessel support $\frac{1}{8}$ ”, remove simulated assembly, replace with load cell and accessory, and gently lower vessel.
- Shim as required to plumb load cells and equalize tare weight among the cells.

FLEXURE BEAMS

Flexure beams can be substituted for load cells and fixed mounting plates in lower accuracy weigh systems. Flexure beams are generally used for nonagitated vessels containing self-leveling materials, operating at constant ambient temperature.

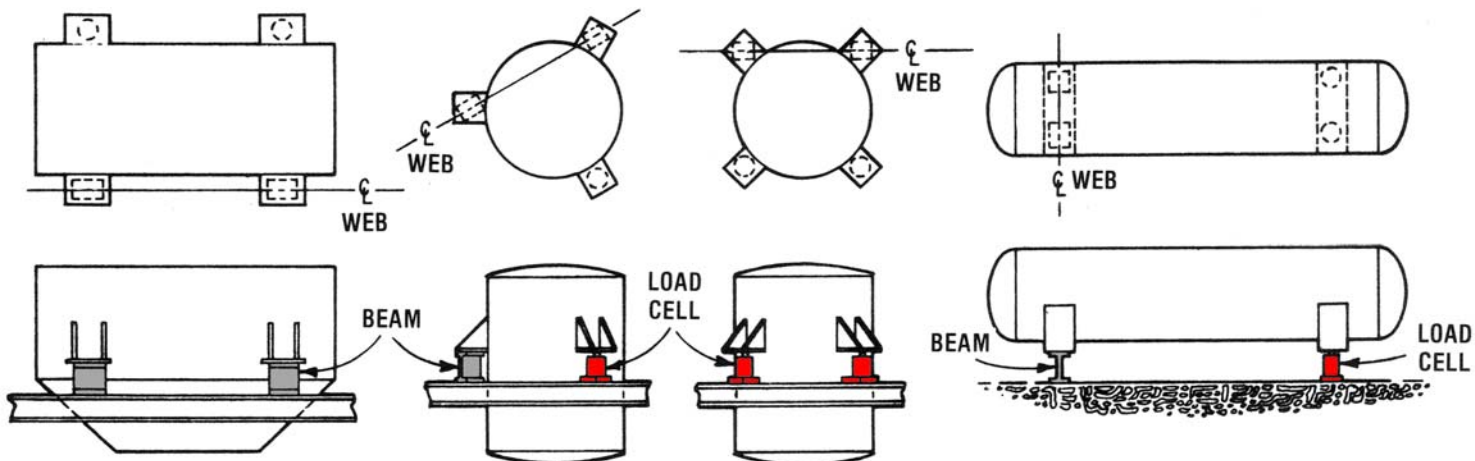
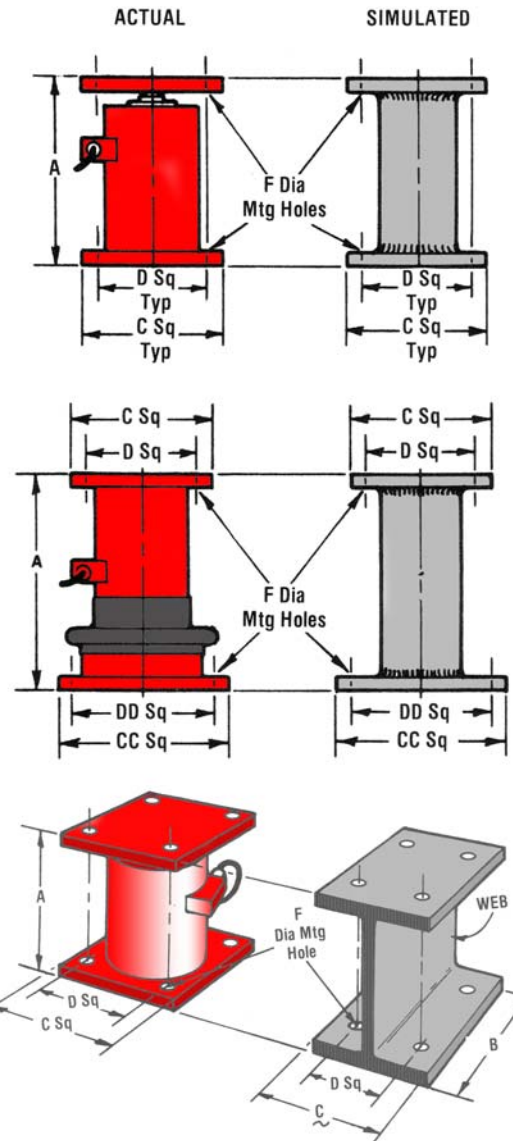

APPLICATIONS: Align beam webs so vessel can pivot with load cell deflection, thus providing a flexibility to vessel support that may not occur when web is opposed to cell deflection.

Accessory selection and installation

Load cells in compression (continued)

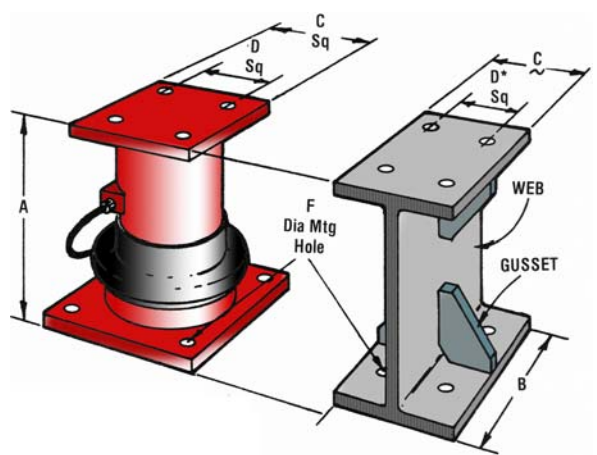

BEARING BEAMS

Bearing beams, substituted for load cells and expansion assemblies in lower accuracy weigh systems, are generally used on vessels containing self-leveling materials with no agitation. Since gussets are required to preclude buckling of the beam web, negligible beam motion occurs under vessel expansion: all vessel growth must be accommodated by the expansion assembly.

STAY RODS

Stay rods provide positive lateral restraint for vessels with agitators or vibrators; hold vessel centered on expansion assemblies so full design travel is assured. Since stay rods are an active part of the weigh system, install level to ensure a linear response with deflection. (see illustrations pages ?? and ??)

SAFETY CHECK RODS

Safety check rods provide backup restraint capability for unlikely events - high wind, seismic, wayward forklift, etc. - when vessel center-of-gravity is above support plane (and stay rods). Check rods are normally passive members, adding only to the tare weight of the vessel. (see illustrations pages ?? and ??)

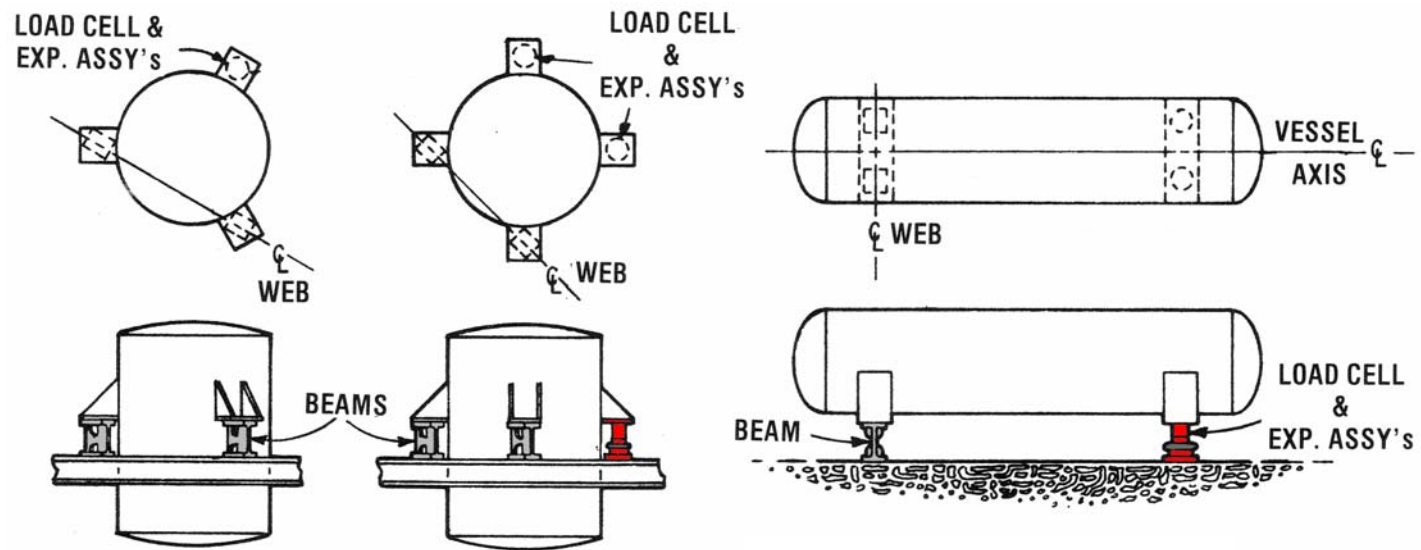

APPLICATIONS: Align beam webs so vessel can pivot with load cell deflection

Accessory selection and installation

Load cells in compression (continued)

Stay rods for horizontal tanks on load cells and fixed mounting plates -

General rule:

Locate lateral rods close to the ends of tank for maximum leverage against piping moments tending to rotate the tanks.

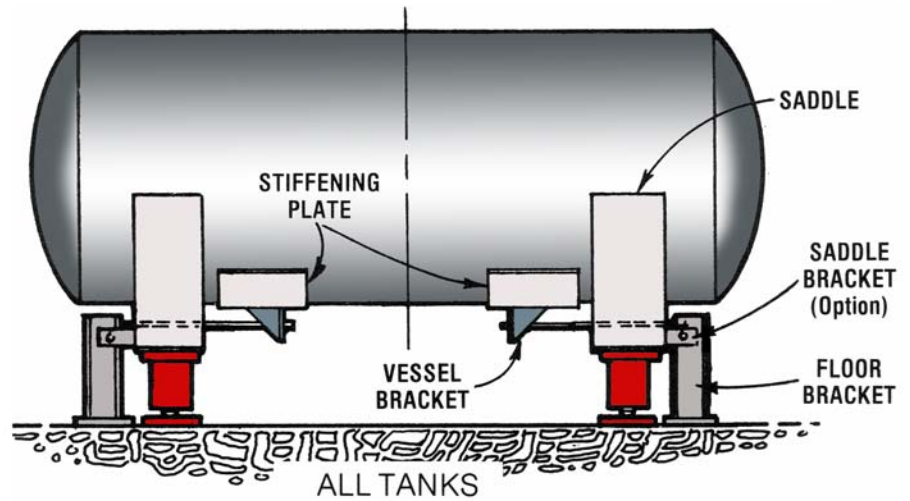

Stay rods for horizontal tanks on load cells and flexure beams -

General rule:

Locate lateral rods close to ends of tank for maximum leverage against piping moments tending to rotate the tanks.

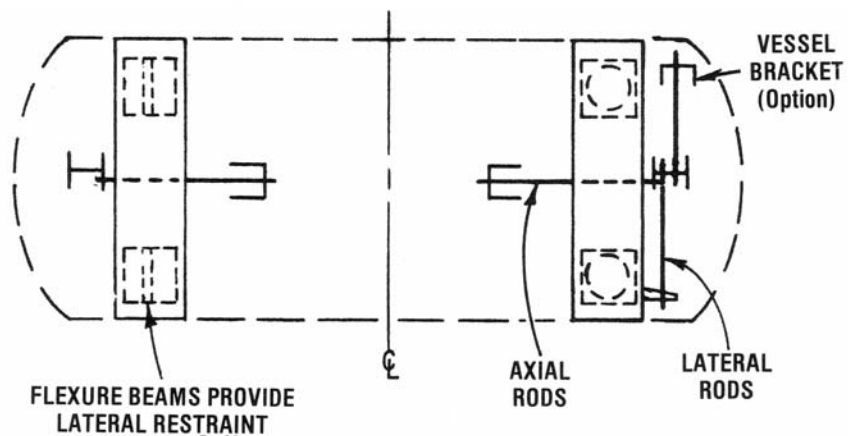
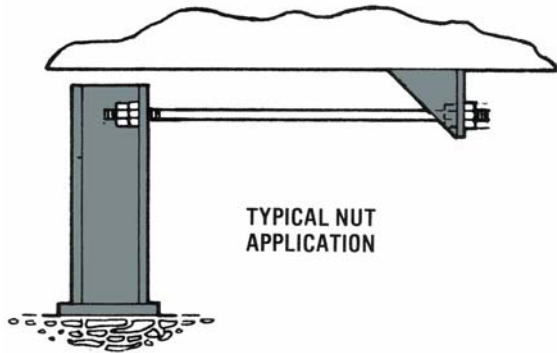
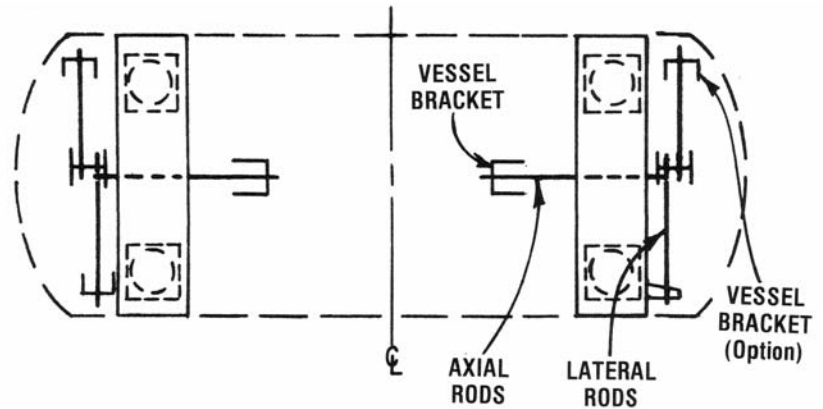

Locate lateral rods close to ends of tanks for maximum leverage against piping moments

Accessory selection and installation

Load cells in compression (continued)

Stay rods for horizontal tanks on load cells and expansion assemblies -

General rules:

Locate lateral rods close to ends of tanks for maximum leverage against piping moments tending to rotate the tanks. (Leave room for vessel expansion between floor bracket and saddle.)

Locate vessel-mounted axial restraint brackets close to tank center to minimize slackening of stay rod due to tank thermal expansion. (On longer tanks, axial rods extending all the way to the lateral rod brackets cannot be used due to excessive rod elongation under load.)

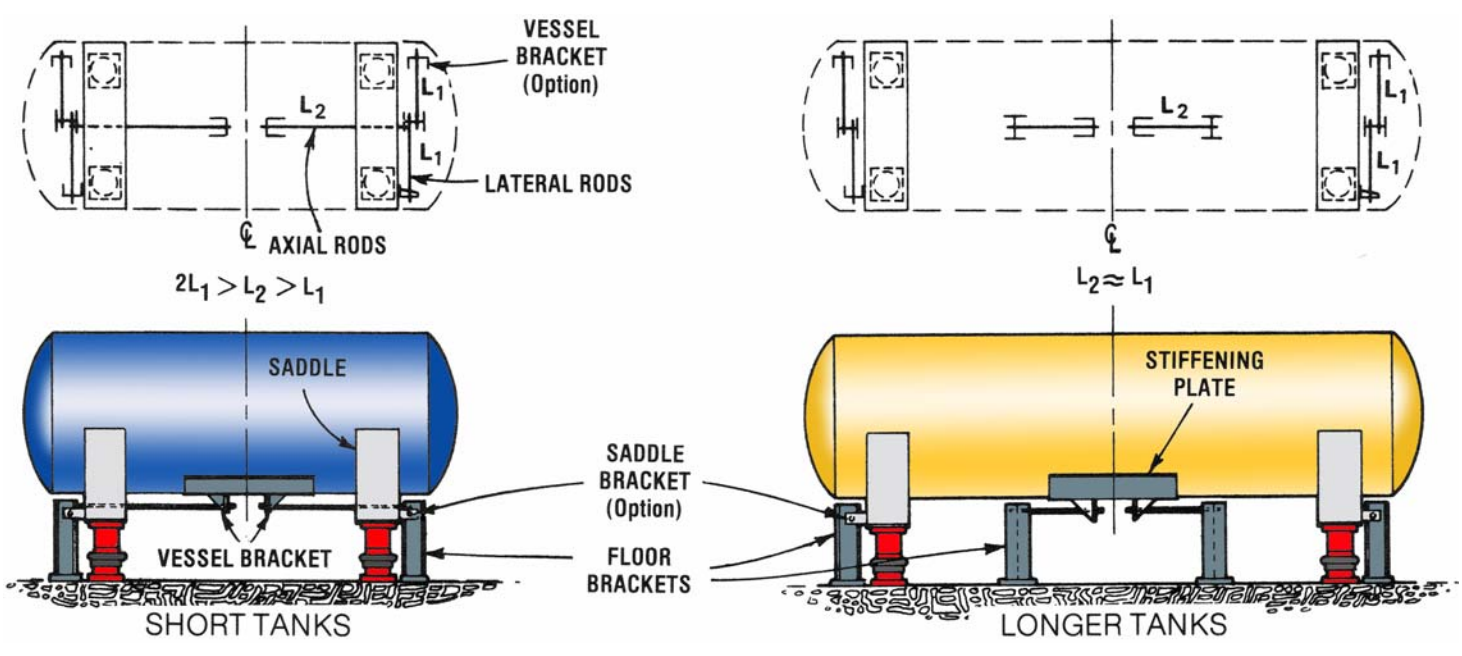

Accessory selection and installation

Load cells in compression (continued)

Stay rods for horizontal tanks on load cells and bearing beams -

ESTIMATE TRAVEL, $\delta = L \alpha \Delta T$
 WHERE, α = COEFFICIENT OF THERMAL EXPANSION
 ΔT = MAX. TEMP. DIFFERENCE BETWEEN
 VESSEL AND SUPPORT STRUCTURE =
 (MAX. VESSEL OPERATING TEMP. - MIN.
 AMBIENT TEMP.)

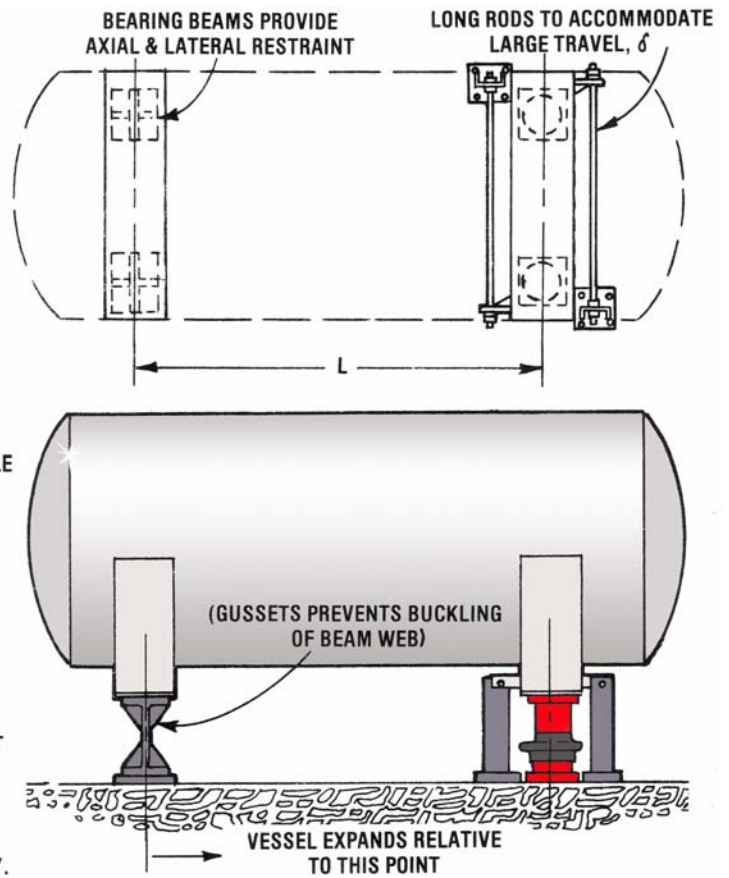
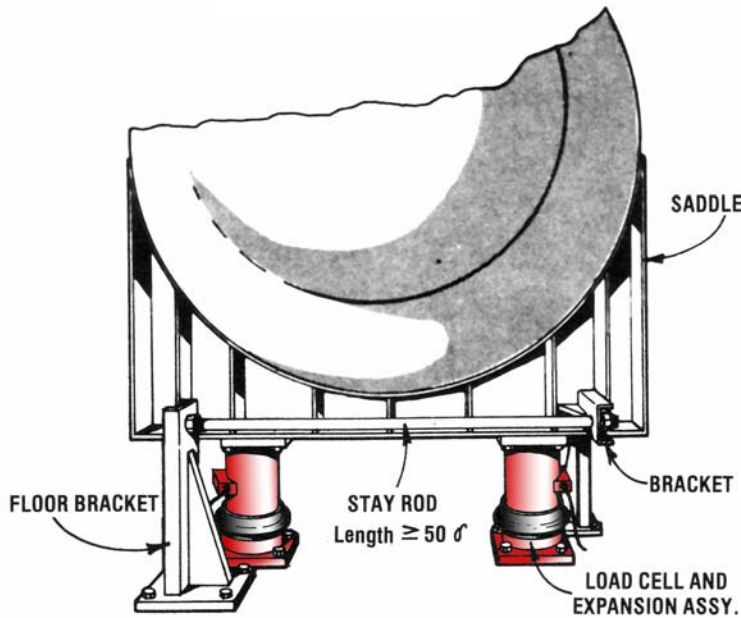

Accessory selection and installation

Load cells in compression (continued)

Stay rods for hoppers and bins, any temperature -

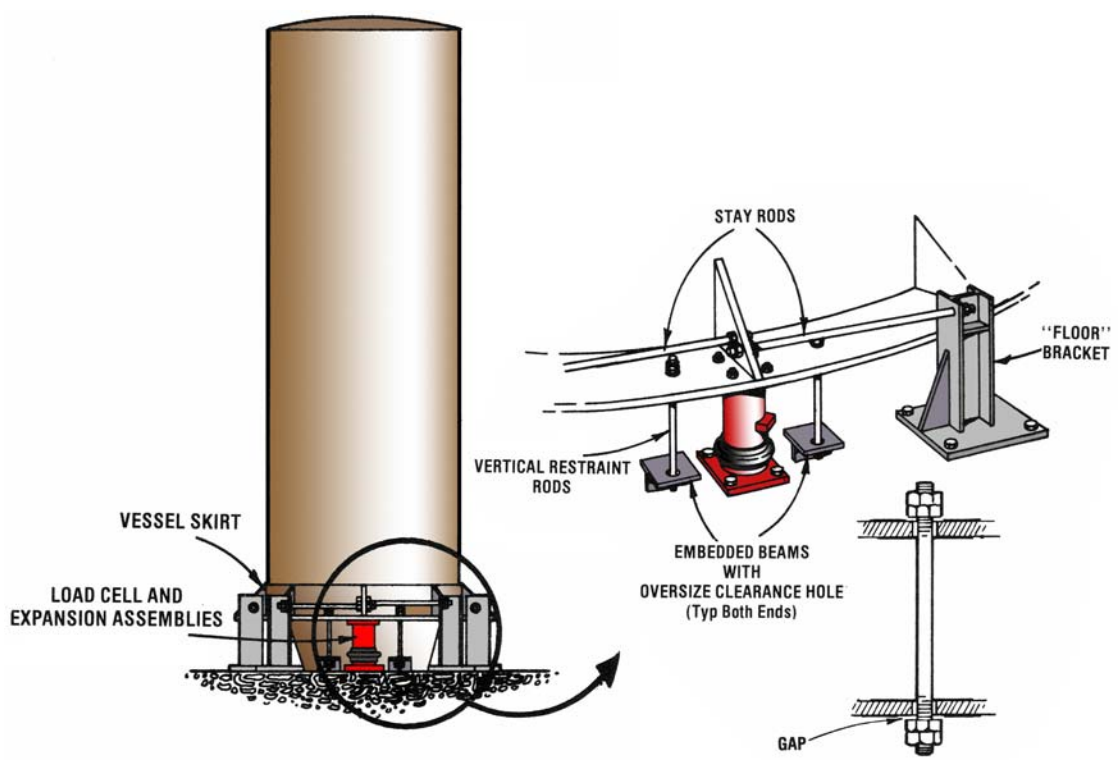
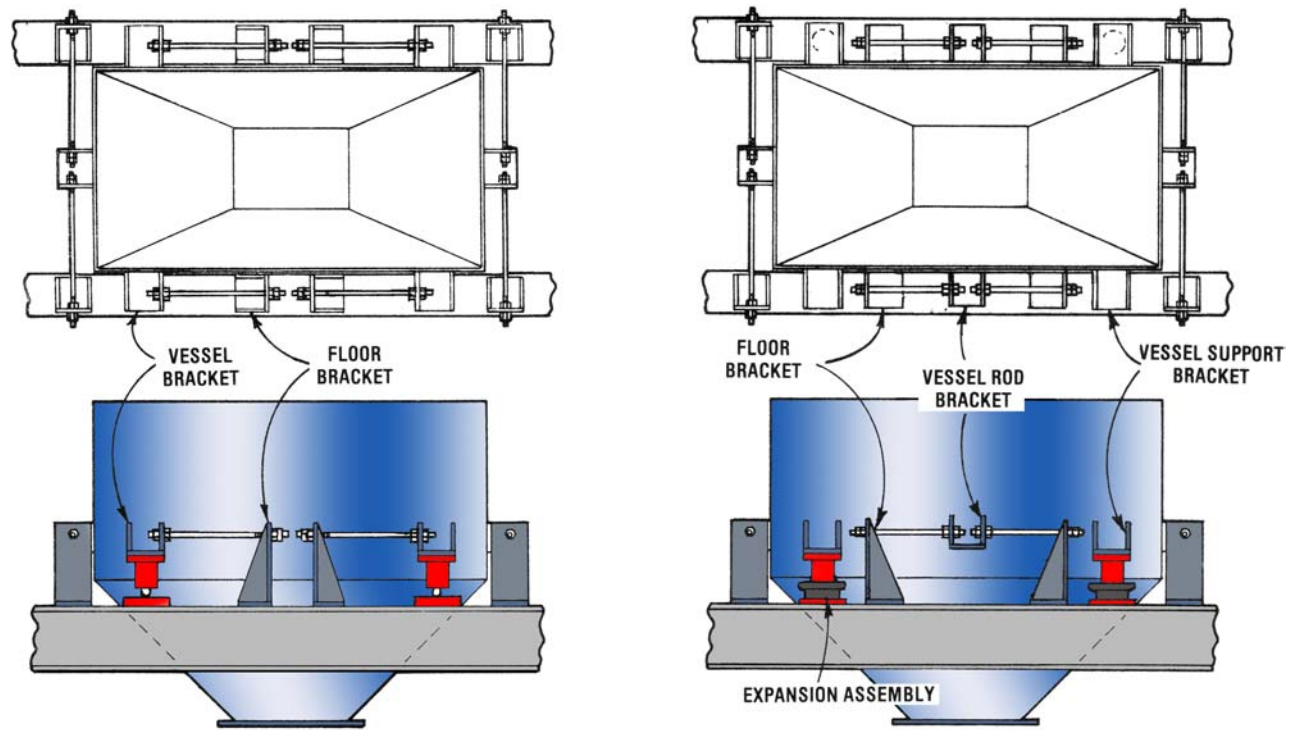

Stay rods and vertical restraint rods for tall outdoor vessels without surrounding structure -

When tall vessels must be protected against tipping due to wind or seismic forces and safety check rods are impractical, use "vertical restraint rods" (loose fitting check rods) at the base of the vessel as shown. The vertical restraint rod must not be tightened since this would load the load cell and possibly damage the load cell if overloaded.

Accessory selection and installation

Load and “S” cells in tension

Tension flexure rod usage -

Tension flexure rods are used to suspend weigh vessels from an overhead structure. Preferred for heated vessels over compression arrangements since side loading is all but eliminated. Chief deterrent is the cost of support structure, which effectively limits cell capacity to 50,000 lbs. A minor consideration is increased vessel displacement and vibration sensitivity due to rod elongation with load.

General design rules:

1. Overall length between support surfaces, **S** must be larger than either:

a. The length which holds the maximum change in initial load/S-cell plumb due to differential thermal expansion between vessel and support structure to within $\frac{1}{4}$ degree. (This renders changes in calibration accuracy due to “Cosine Error” trivial.) Calculate this minimum length as:

$$S_{\min} = 230R\alpha\Delta T$$

WHERE **R** = Distance between support point on vessel bracket and centerline of vessel
 α = Coefficient of thermal expansion of the vessel
 ΔT = Max. temperature difference between vessel and supporting structure, usually taken as max. vessel operating temperature less min. ambient temperature

b. The length which from Vishay BLH experience, imparts the required degree of flexibility to the tension linkage. **S min** ranges from 20 inches for a 50 lb load/S-cell to 40 inches for a 50,000 lb cell.

EXAMPLE: An eight foot diameter stainless vessel operates at 470° in an ambient environment at 70°F. Taking **R** to be about 56", **S** \geq 50".

2. Optimum load /S-cell placement is midway between support points. Doing this minimizes readout error due to moments acting across the cell.

3. Request Vishay BLH Electronics Data Sheet entitled “Technical Data for Calculating Rod Lengths” (TD-063) for detailed instructions and ordering information.

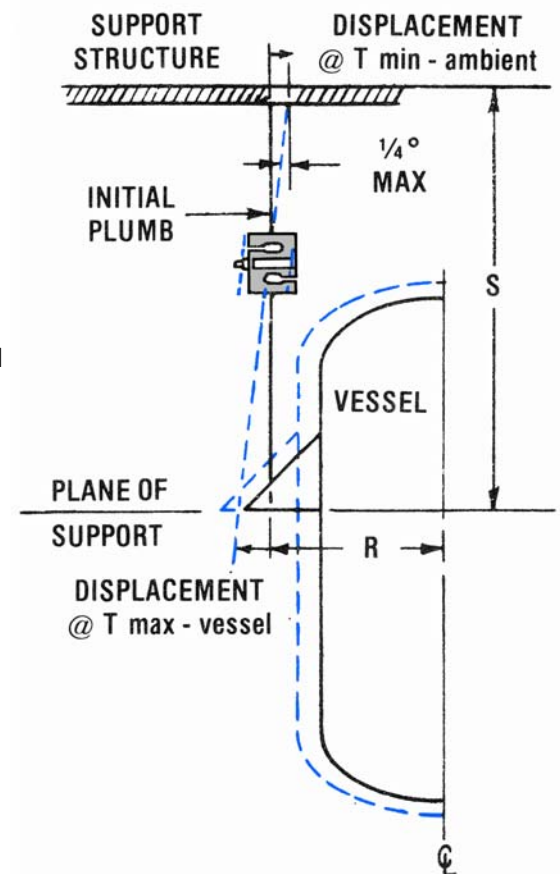

Accessory selection and installation

Load and “S” cells in tension

Errors due to swaying -

When vessels are suspended, care must be taken that the amount of swaying is limited. These errors, often small in weigh vessels, can be substantial in crane scales. The error is introduced due to the centrifugal force generated when the weight moves through the bottom of its arc, similar to the pendulum in a clock. The frequency of the acceleration force is therefore twice the pendulum frequency or

$$f_r = 2 \times \frac{1}{2\pi} \sqrt{\frac{g}{s}}$$

where g is the gravity constant (s is defined on the preceding page). The centrifugal force is proportional to the increase in height of the weight.

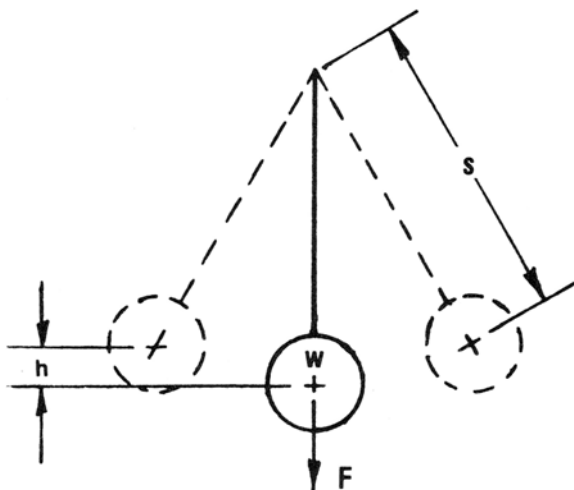

$$f = w \frac{h}{s}$$

Installation sequence for compression load cells

Preferred method - recommended for High Accuracy Systems

- Fabricate, or order from Vishay BLH, Simulated Load Cells and Fixed Mounting Plates or Simulated Load Cells and Expansion Assemblies. Bolt to vessel support bracket.
- Lower vessel in place and align.
- Using lower Simulated Assembly flange as a template, drill mounting holes in mating support structure, and bolt securely.
- Install lateral restraints, if required, to maintain vessel alignment for all subsequent operations. Complete vessel fabrication and installation. Make all piping connections, weld, insulate, etc. Loosen and remove all lower flange bolts.
- Using a hydraulic jack, lift vessel $\frac{1}{8}$ " only at each bracket, one at a time. Remove Simulated Assembly; install load cell; shim plumb to within $\frac{1}{2}$ "; install accessory (bearing plate, expansion assembly base, etc).
- LOWER VESSEL GENTLY to avoid overload damage to load cell.
- Repeat load cell installation operation at each bracket.
- Loosen all stay rods to remove any possible restraint, recheck level to within $\frac{1}{2}$ °, and secure snug tight.
- When done, check load distribution among the cells, shimming if necessary.

see alternate method on following page

Installation sequence for compression load cells (continued)

Alternate method - suitable for Lower Accuracy Systems

- Install lateral restraints, if required. Set level within $\frac{1}{2}^\circ$.
- Bolt load cells in place; visually check load cell plumb, shimming if necessary; install accessory.
- LOWER VESSEL GENTLY onto load cells.
- Check load distribution among cells, shimming as required.

Expansion assemblies for compression load cells

Expansion Assemblies accommodate thermal expansion or contraction of a vessel relative to support structure with minimum side loading of the load cell. They are generally necessary outdoors when maximum accuracy is desired or indoors when the vessel temperature differs from ambient. An Expansion Assembly includes a low friction slide plate in the “base assembly”, a “load plate”, and the appropriate load cell mounting screw(s). For details, refer to instructions shipped with unit.

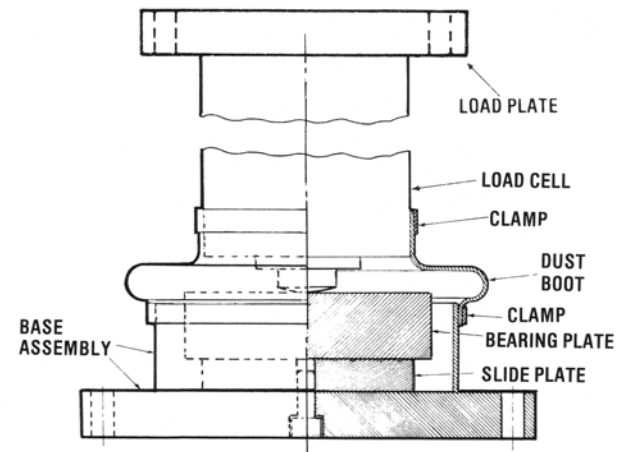

Load distribution for compression load cells

Shim load cells plumb (first)

Stagger shims or shim segments between the load plate and support, as shown in sketches (at right). Tighten securely and check that cell is now plumb within $\frac{1}{2}^\circ$. Repeat procedure until plumb. Do not disturb the load cell thereafter.

Shim for load distribution

With full tare weight resting on load cells, measure output of each cell with a readout instrument such as a Vishay BLH Model DXp-40 Weight Transmitter or equivalent. Shim as required to ensure that the tare weight is distributed on each load cell to within 10% of each other cell. If any cell indicates “no” output during this test, use a feeler gage to measure gap between load button of cell and bearing plate (or mating accessory), raise vessel, unfasten bearing plate, and insert a trial shim having a thickness of 0.015 - 0.030 inches plus the gap height. Similarly, if a cell indicates “low” output, insert a 0.015 - 0.030 inch trial shim. Secure bearing plate and GENTLY LOWER weighed structure onto load cells. Since adjustment at one load cell alters load distribution at all support points, measure the output of each load cell again. Repeat this shimming measurement procedure until all load cells read within 20% of each other.

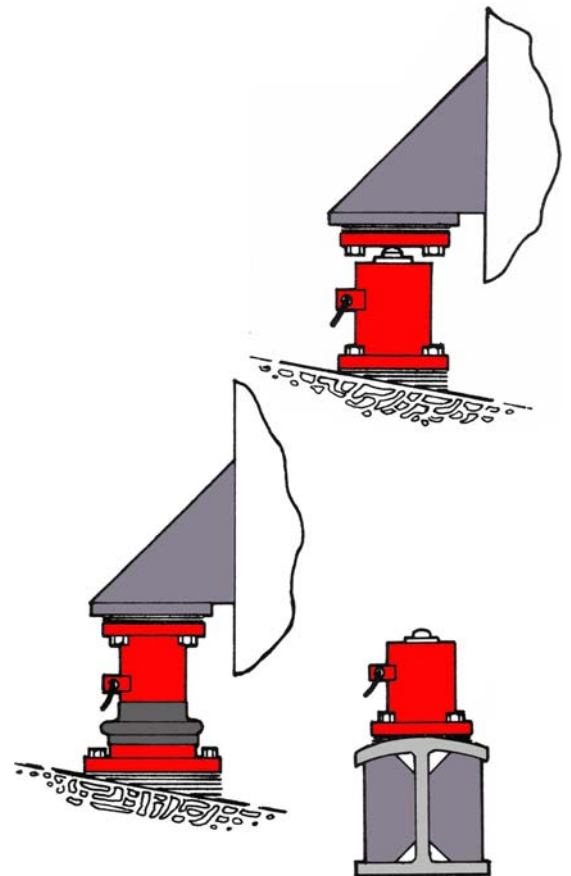

Vishay BLH Field Engineering Services are available upon demand to perform on-site start-up, calibration, repairs, and training. Factory direct and authorized, independent service engineers are specialists in maximizing the performance and reliability of process weighing and web tension measurement systems. Due to their expertise, contracting BLH for start-up and calibration is a time and cost effective alternative to using in-house, technical personnel or untrained local scale dealer organizations.

Field Service Engineers are equipped and trained to perform a wide range of calibration procedures. Available service contracts offer a turnkey calibration program that includes full computer generated documentation of results and traceability of methods and equipment.

The field service group also offers a free document entitled ‘Calibration Methods and Procedures for Process and Inventory Weigh Systems’ (FSD 001) to assist in understanding and selecting the best calibration method for your application.

Call (781) 298-2216 for immediate assistance with all your service and training needs.



Vishay BLH Field Service on-site training session

Vishay Transducers Sales Offices Worldwide

**VTS Americas
Systems Products
Norwood, MA**
PH: +1-781-298-2200
Fax: +1-781-762-3988
vts.us@vishaymg.com

**VT Canada
Toronto**
PH: +1-416-251-2554
Fax: +1-416-251-2690
vt.can@vishaymg.com

**VT Sweden
Karlskoga**
PH: +46-586-630-00
Fax: +46-586-630-99
vt.se@vishaymg.com

**VMG UK
Basingstoke**
PH: +44-125-646-2131
Fax: +44-125-647-1441
vt.uk@vishaymg.com

**VMG Germany
Heilbronn**
PH: +49-7131-3901-260
Fax: +49-7131-3901-2666
vt.de@vishaymg.com

**VMG France
Chartres**
PH: +33-2-37-33-31-20
Fax: +33-2-37-33-31-29
vt.fr@vishaymg.com

**VMG Israel
Netanya**
PH: +972-9-863-8888
Fax: +972-9-863-8800
vt.il@vishaymg.com

**VT Norway
Systems Products
Oslo**
PH: +47-22-88-40-90
Fax: +47-22-88-40-99
vt.no@vishaymg.com

**VT Finland
Systems Products
Jorvas**
PH: +358-9-8194-220
Fax: +358-9-8194-2211
vt.fi@vishaymg.com

**VT China
Tianjin**
PH: +86-22-2835-3503
Fax: +86-22-2835-7261
vt.prc@vishaymg.com

**VT Taiwan*
Taipei**
PH: +886-2-2696-0168
Fax: +886-2-2696-4965
vt.roc@vishaymg.com
*Asia except China