

Load Cell Weigh Module

FEATURES



- Available in Capacities from 10K to 75K Pounds
- Self-Checking Design Allows for Thermal Expansion
- Conduit Adapter Available (Stainless Steel Modules)
- Ideally Suited for Applications with High Deadload to Liveload Ratios
- Electroless Nickel Plated Load Beam Standard, Welded Stainless Steel Load Beam Available
- Sealed to IP67 Standards
- FM Approved

DESCRIPTION

PRO-Mount Weigh Modules are specifically engineered to meet the requirements of inventory and ingredient management weighing applications. Checkless design (no stay or check rods), low profile, and uniform bolt spacing simplify installation on new and existing vessels. An integral expansion assembly and temperature compensated full bridge transducer design, minimize temperature effects allowing accurate measurement indoors or out, in virtually any environment.

Optional stainless steel, welded units are available for caustic or washdown environments. Stainless steel units also have an integral conduit adapter.

PRO-Mount design considerations ensure an efficient balance between performance as a transducer and strength as a structural member when earthquake risk or wind resistance is a system factor. Sideloads of up to 100% full scale capacity, caused by vibration or other extraneous forces, virtually have no effect on weight measurement.

APPLICATIONS

- Storage Tank, Bin, and Hopper Weighing
- Silo and Inventory Measurement Systems
- Loss-In-Weight Feeders

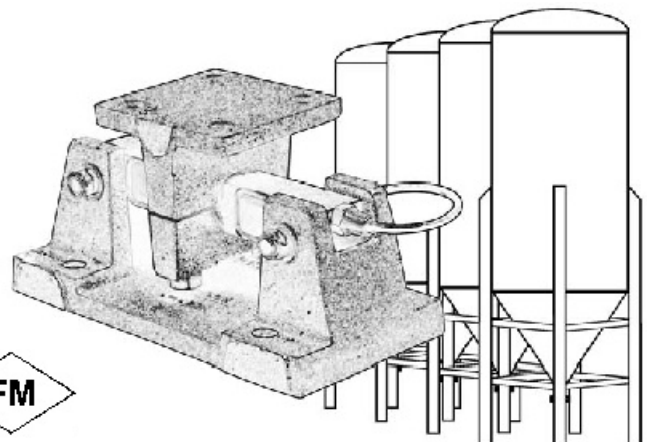

SPECIFICATIONS

PERFORMANCE

Capacities	10K, 15K, 25K, 35K, 50K, & 75K lb
Rated Output (RO)	3.0 mV/V +/-0.25%
Repeatability	0.01% RO
Combined Error	0.03% RO
Zero Balance	1% RO
Creep (20 minutes)	0.03% RO
Temperature Effects:	
On Zero Balance	0.0015%RO/°F
On Span	0.0008%Load/°F

ELECTRICAL

Recommended Excitation	10 Vdc (15 Vdc max.)
Input Resistance	686-714 ohms
Output Resistance	699-707 ohms
Cable Length	25 foot cable with 4 wire polyurethane jacket

TEMPERATURE

Safe Range	0 to +150°F
Compensated Range	+14 to +104°F

ADVERSE LOAD RATINGS

Safe Load	150% Rated Capacity
Safe Sideload	100% Rated Capacity
Ultimate Load	300% Rated Capacity

MATERIAL

Beam (standard)	tool steel, electroless nickel plated
Beam (option)	17-4 PH stainless steel
Mounting Hardware (std)	cast steel, zinc plated
Mounting Hardware (opt)	stainless steel

SEALING

Environmental Class	IP67
---------------------	------

DEFLECTION

10K - 25K lb	0.022 inches
35K lb	0.038 inches
50K lb	0.052 inches
75K lb	0.070 inches

APPROVALS

FM	Class I, II, III; Divisions 1 and 2, Groups A-G
----	---

Vishay BLH is continually seeking to improve product quality and performance. Specifications may change accordingly.

OUTLINE DIMENSIONS

PRO-Mount Dimensions (shown in inches)											
Capacity	A	B	C	D	E	F	G	H	J	K	Weight
10 - 35K	7.90	12.00	8.00	7.50	6.00	8.00	6.00	0.78	0.75	0.75	73.0
50 - 75K	9.30	16.25	12.00	11.50	9.50	9.00	6.50	0.78	1.00	1.00	172.0

Capacities shown in pounds.

