Software Revision 5.07



Electro-Pneumatic Positioner TZID

Operating Instructions

Document No.: 42/18-54 EN

Issued: 07.07

Manufacturer

ABB Automation Products GmbH

Schillerstr. 72

32425 Minden

Germany

Tel: +49 551 905-534

Fax: +49 551 905-555

CCC-support.deapr@de.abb.com

© Copyright 2007 by ABB Automation Products GmbH

Modifications reserved

This document is subject to copyright. It is intended to help the user operate the equipment safely and efficiently. The content may not be copied or reproduced either in part or in full without the prior consent of the copyright owner.





Important information	5
1 Safety summary	6
1.1 General safety instructions	6
1.2 Device-specific safety instructions	7
1.2.1 General.....	7
1.2.2 Pneumatic safety.....	7
1.2.3 Electrical safety.....	8
1.3 Explosion protection	9
1.4 Correct use	9
1.5 Qualified personnel	10
2 Manufacturer's information	10
2.1 Delivery	10
2.2 CE compliance information	10
3 Installing and commissioning	11
3.1 Mechanical mounting	11
3.1.1 General.....	11
3.1.2 Operating conditions at the installation site.....	12
3.1.3 Mounting to linear actuators.....	13
3.1.4 Mounting to rotary actuators.....	16
3.2 Pneumatic connection	21
3.2.1 Safety instructions.....	21
3.2.2 Making the pneumatic connection.....	21
3.3 Electrical connection	23
3.3.1 Safety instructions.....	23
3.3.2 General installation instructions.....	23
3.3.3 Overview.....	24
3.4 Commissioning	26

3.4.1	Adapting the positioner to the actuator	26
3.4.2	Adjusting the tolerance band	27
3.4.3	Adjusting the valve action	27
3.4.4	Setting parameters for current operation	27
3.4.5	Adjusting low and high alarm limits (supplem. modules for digital feedback) .. 28	
3.4.6	Adjusting low and high alarm limits (supplementary “mechanical kit for digital feedback”)28	
3.4.7	Restoring the factory setting	29
3.4.8	Performing the Autostroke	29
4	Display and operator panel	31
4.1	Operating level 1	32
4.2	Operating level 2	33
5	Maintenance	36
5.1	Functional test/Readjustment	36
5.2	Checking/replacing the filter regulator	36
5.3	Checking the air filter in the positioner	37
5.4	Replacing the pneumatic output unit	38
6	Technical data	39
6.1	Basic model.....	39
6.2	Options	43
1	Certificates.....	45
	Appendix A: Error codes.....	64

Important information

Symbols

In order that you can make the best use of this document and to ensure safety during commissioning, operation and maintenance of the equipment, please note the following explanation of the symbols used:

Symbol	Signal Word	Definitions
	DANGER	DANGER indicates an imminently hazardous situation which, if not avoided, will result in death or serious injury. (High level of risk.)
	WARNING	WARNING indicates a potentially hazardous situation which, if not avoided, could result in death or serious injury. (Medium level of risk.)
	CAUTION	CAUTION indicates a potentially hazardous situation which, if not avoided, could result in minor or moderate injury. (Low level of risk.)
	NOTICE	NOTICE indicates a potentially harmful situation which, if not avoided, may result in damage of the product itself or of adjacent objects. (Damage to property)
	IMPORTANT	IMPORTANT indicates useful hints or other special information which, if not observed, could lead to a decline in operating convenience or affect the functionality. (Does not indicate a dangerous or harmful situation.)

As well as the instructions in this document, you must also follow the generally applicable accident prevention and safety regulations.

If the information in this document is insufficient in any situation, please contact our service department, who will be happy to help you.

Please read this document carefully before installation and commissioning.

1 Safety summary

1.1 General safety instructions

This chapter provides important instructions for your safety. Thoroughly read and follow these instructions.

Proper and safe operation of the TZID positioner requires:

- proper transportation and storage
- mounting, electrical and pneumatic installation and commissioning by qualified personnel (see chapter 1.5, page 10)
- correct operation according to the instructions in this manual
- correct use (see chapter 1.4, page 9)
- careful maintenance

The regulations, standards and directives referred to in this manual are applicable in Germany. When using the TZID positioner outside the German jurisdiction, the relevant regulations, standards and directives applicable in the country where the device is used must be observed.

The TZID positioner has been designed and tested in accordance with DIN VDE 0411 Part 1 / EN 61 010 Part 1

“Safety Requirements for Electronic Measuring Apparatus”

(based on IEC Publication 348) and has been delivered in a safe condition.

In order to retain the device in a safe condition and ensure safe operation, attentively read and follow the instructions given in the sections marked with the respective symbols. (See “Important information” on page 5.) Otherwise, persons can be endangered or the device itself or other devices or equipment may be damaged or fail.

The device must be shut down and secured reliably against unintentional restart if it must be assumed that safe operation is no longer ensured. Possible reasons for this assumption can be:

- visible damage of the device
- failure of the electrical function
- exposure to a storage temperature of more than 85 °C for a longer time period
- exposure to considerable strain or wear during transport

Only the manufacturer is authorized to repair the device.

1.2 Device-specific safety instructions

1.2.1 General



WARNING

- Any user-made changes or manipulations of the device are prohibited! Only the manufacturer or an expert for explosion protection are authorized to modify the device.



CAUTION

- The TZID rotating shaft can only be rotated in the direction of the indicating arrow on the shaft. There are no mechanical stops to limit the actuator movement. Improper mounting can damage the device and void warranty.

1.2.2 Pneumatic safety



WARNING

- Observe the accident prevention rules of the Employers Liability Insurance Association.
- Observe the safety instructions for the pneumatic actuator used. The actuator's high actuating power may cause injuries!



CAUTION

- Take suitable precautions to ensure that even in case of malfunctions the positioner's max. admissible operating pressure of 6 bar (90 psi) is not exceeded. Otherwise, the positioner and/or the actuator may be damaged.
- The positioner must be supplied with instrument air exempt from oil, water and dust according to DIN/ISO 8573-1, Class 3
 - Purity: max. particle size 5 μm , max. particle density 5 mg/m^3
 - Oil content: max. concentration 1 mg/m^3
 - Pressure dew point: maximum value 10 K below operating temp.

Before connecting the air pipes blow them out to remove dust, splinters and other particles.

1.2.3 Electrical safety



WARNING

- Observe the common VDE safety regulations and the accident prevention rules of the Employers Liability Insurance Association.
- Observe the common standards and safety regulations for the installation and operation of electrical systems.
- When connecting the device, observe all electrical specifications in these operating instructions or in the data sheet.
- For the electrical installation of explosion-protected devices, observe all standards, regulations and directives governing explosion protection and applicable for the construction and use of explosion-protected systems, especially the DIN/VDE directives, the directives for explosion protection (VDE 0165 or EN 60079), and the special requirements and specifications for your devices (see the following chapter "Explosion protection" and chapter "Certificates").
- Explosion-proof devices may only be supplied with safe extra-low voltage (SELV) according to EN 60 950.



NOTICE

Electromagnetic interference

- Do not lay signal lines close to power lines. Power lines produce interference in their near vicinity, which may affect measured value transmission on the signal line.

1.3 Explosion protection

One of the type plates seen below is attached to the positioner to the left of the main type plate, depending on the positioner's explosion protection. It indicates the degree of explosion protection and the certificate valid for your positioner. For details please refer to chapter "Certificates".



WARNING

Always observe the specifications and special requirements for your positioner stipulated in the applicable certificate.



Fig. 1 Type plates indicating the degree of explosion protection

1.4 Correct use

The TZID positioner is an electro-pneumatic positioner for pneumatic final control elements. It is designed for being attached to linear and rotary actuators following the instructions in this manual. The positioner may be used only for the applications listed in these operating instructions or in the data sheet 18-0.20 EN. Any other use is considered as incorrect.

The signal current circuit and the input and output circuitry must meet the explosion protection requirements stipulated in the certificates (see the certificates).

The maximum permissible ambient temperature range of -40 °C to +85 °C must not be exceeded.

1.5 Qualified personnel

Only those persons familiar with the installation, commissioning, operation and maintenance of the TZID positioner or similar instruments who have the required qualification and have read and understood the operating instructions are authorized to work on the TZID positioner. These persons must be sufficiently trained and experienced and know the relevant standards and regulations to be able to judge their assigned tasks and recognize potential hazards. Only persons who are qualified or have been trained adequately and who have the required certificates are authorized to work on explosion-protected devices.

2 Manufacturer's information

2.1 Delivery

When receiving the delivery please immediately check items and scope for intactness and completeness. The scope of delivery is stated in the shipping documents. If ordered, the accessories (e.g. mounting material, pressure gauge block, filter regulator) are added to the delivery as individual items. Check items and scope of the delivery by means of the catalog numbers to see if types and quantities are in accordance with your order. If the positioner is delivered already mounted to the actuator, the positioner, accessories and actuator or final control element are considered as a common delivery item. A list of catalog numbers and details of the different versions and accessories can be found in data sheet 18-0.20 EN.

2.2 CE compliance information

We declare that we are the manufacturer of the TZID positioner and that the product conforms with the EMC Directive 89/336/CEE as of May 1989 and meets the requirements of the following standards:

- EN 55022:1998 "Information technology equipment, Radio disturbance characteristics, Limits and methods of measurement"
- EN 61000-6-2:8/2002 "Electromagnetic compatibility (EMC)
Part 6-2: Generic standards - Immunity for industrial environments"
- EN 61000-6-3:3/2000 "Electromagnetic compatibility (EMC)
Part 6-3: Generic standards - Emission standard for residential, commercial and light-industrial environments"

The TZID positioner complies with the EC directive for CE conformity certification.

3 Installing and commissioning

3.1 Mechanical mounting

3.1.1 General

i
IMPORTANT

- No further steps are required if the TZID positioner is delivered mounted to an actuator.
- These operating instructions describe how to mount the positioner to linear actuators in accordance with DIN/IEC 534 (lateral attachment to NAMUR) and to rotary actuators in accordance with VDI/VDE 3845. Customized positioners for actuator-specific attachment require special instructions, which are already delivered with the device or can be ordered from us.

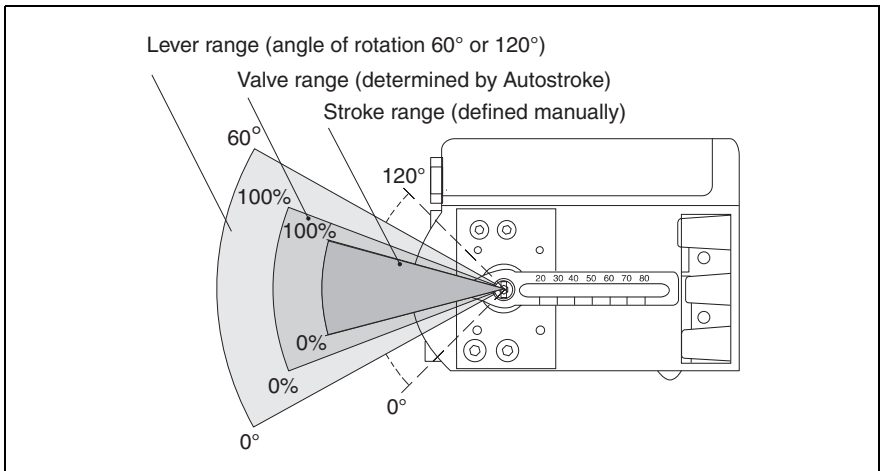

Fig. 2 Range definition for positioner TZID

When mounting the positioner, ensure that the transfer of the stroke or rotation angle for the position feedback is correct.

The maximum rotation angle is 60° for mounting to linear actuators and 120° for mounting to rotary actuators.

Due to the high-resolution A/D conversion (> 8000 steps) no extra adjustment of the used angle of rotation is necessary when mounting the positioner. Fine adjustment is done later in the commissioning phase through electronic configuration (Autostroke).

For safety reasons, the range actually covered by the positioner's angle of rotation should not reach the limits of the total range, but should be greater/smaller than these limits by 2%. While commissioning the positioner, you can determine its angle of rotation by using an electronic parameter.

The actually used angle of rotation should be at least 20% of the total range. This value can also be determined electronically in the commissioning phase.

3.1.2 Operating conditions at the installation site



WARNING

Before installing check to ensure that the specifications in terms of safety and control applicable to the TZID positioner will not be exceeded at the installation site of the actuator or final control element.

Ambient temperature:	-40 °C ... +85 °C
Relative humidity:	95 % (mean annual value), condensation permissible. Observe the specifications for protection class IP65 / NEMA 4X and the technical data in this manual.
Explosion protection:	Observe the technical data, and the specifications in the certificates (see the relevant sections of this manual).
Mounting orientation:	any orientation allowed

3.1.3 Mounting to linear actuators

A mounting kit is available for mounting the positioner to a linear actuator in accordance with DIN/IEC 534. Fig. 3 gives you an overview.

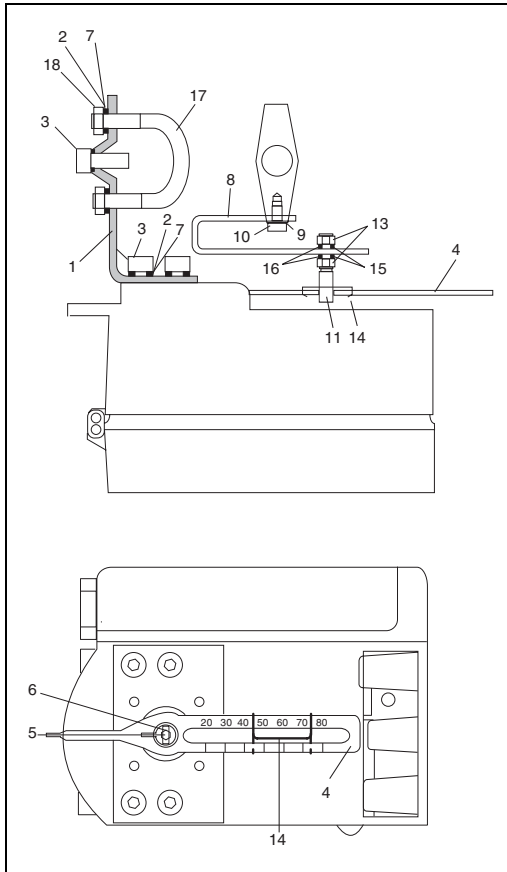

- 1 Angle bracket
- 2 Spring washer B8
- 3 Screw M8x20
- 4 Lever
- 5 Screw M4x8
- 6 Spring washer B4
- 7 Plain washer A8, 4
- 8 Angular slide rod
- 9 Spring washer B6
- 10 Screw M6x10
- 11 Bolt
- 13 Nut M6
- 14 Spring
- 15 Spring washer B6
- 16 Plain washer A6, 4
- 17 U-bolt
- 18 Nut M8

Fig. 3 Mounting kit for linear actuators

The lever (4, standard version), the screw (5), the spring washer (6) and the spring (14) are included in the positioner's delivery. All other items are part of the mounting kit which has to be ordered separately.

The TZID positioner comes with the lever (4) already installed. All other items are delivered in a separate package. The lever is available in two lengths: for 10 to 85 mm strokes (standard version) and for strokes 10 to 150 mm (special version, to be ordered separately).

Fasten the angular slide rod (8) to the actuator stem using the screws M6 (10) and spring washers (9).

Actuators ready for attachment in accordance with DIN/IEC 534 have two vertically arranged threaded holes M6 in the stem.

Fasten the angle bracket to the positioner and to the actuator's cast iron yoke or columnar yoke using the screws and spring washers (2, 3). Proceed as shown in Fig. 4 and Fig. 5.

Mounting the positioner to a cast iron yoke

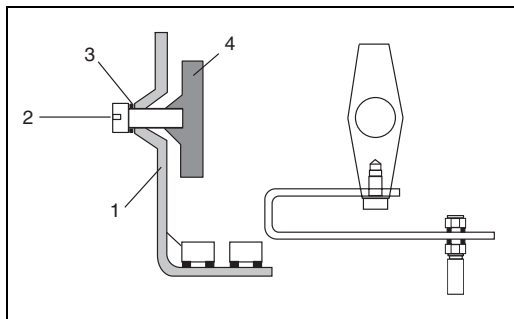

- Fasten the angle bracket (1) with the screw (2) and the plain washer (3) to the cast iron yoke (4).

Fig. 4 Mounting to cast iron yoke

Mounting the positioner to a columnar yoke

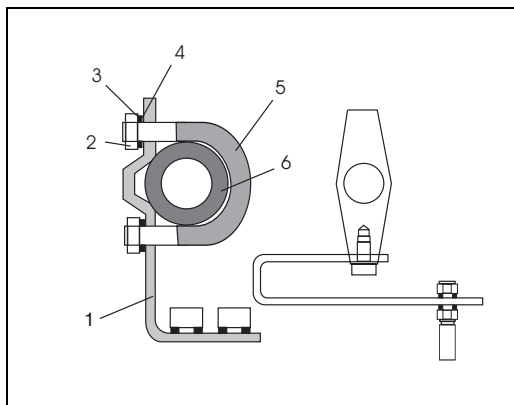

- Hold the angle bracket (1) in the appropriate position against the columnar yoke (2).
- Insert the U-bolts (5) from the inner side of the columnar yoke through the holes in the angle bracket.
- Slip on the plain washers (3), spring washers (4) and nuts (2). Hand-tighten the nuts evenly.

Fig. 5 Mounting to columnar yoke



IMPORTANT

Adjust the height of the positioner at the cast iron yoke or the columnar yoke until the lever is horizontal (at visual check) at half valve stroke.

Adjusting the stroke

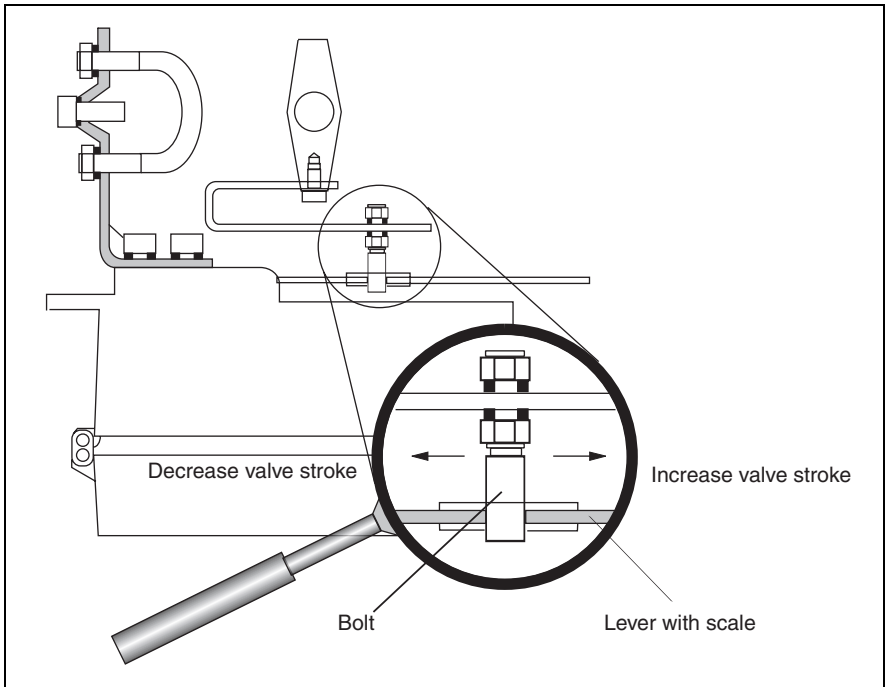

Fig. 6 Positioner linkage

The positioning travel (stroke) is transmitted to the positioner via the bolt. You can adapt the valve stroke range to the operating range of the position sensor by shifting the bolt in the lever's oblong hole. A scale on the lever helps you to determine the valve stroke range.

Use the lever scale to set the bolt to the appropriate position. A rough adjustment is sufficient. The fine adjustment will be done later in the commissioning phase using the Autostroke function.

3.1.4 Mounting to rotary actuators

A mounting kit is available for mounting the positioner to a rotary actuator in accordance with VDI/VDE 3845. Fig. 7 gives you an overview:

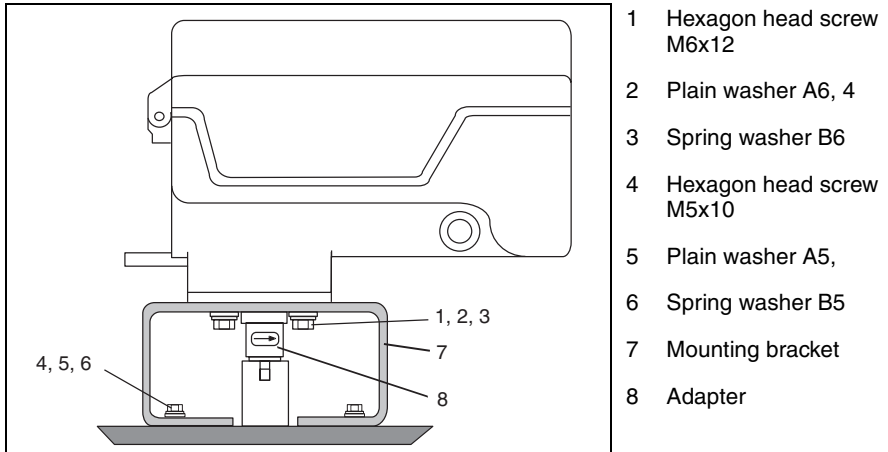

Fig. 7 Mounting to rotary actuators

The TZID positioner is mounted to the rotary actuator using a mounting bracket (7), which has to be ordered separately. At the positioner's back you can find four threaded holes M6 arranged on a 50 mm circle diameter, into which the mounting bracket's fastening screws (1) are screwed. The screws, plain washers (2) and spring washers (3) are included in the positioner's scope of delivery, just as the screws, plain washers and spring washers (4, 5, 6) for attaching the mounting bracket to the actuator.

The adapter (8) is used to couple the accordingly dimensioned positioner shaft with the actuator shaft. Positioners ready for attachment to a rotary actuator are delivered with the adapter already fastened to the positioner.



Pay attention to the following information when mounting the TZID positioner to a rotary actuator:

IMPORTANT

- Position feedback to the positioner is only possible through counterclockwise rotation (seen from the device's front). A built-in return springs turns the shaft until reaching the stop on the right-hand side in the unloaded state.
- The air signal output via OUT1 determines the direction of rotation (counterclockwise or clockwise).
- You can attach the positioner to the actuator either in parallel or shifted by 90°.
- Prior to mounting the positioner to a double acting rotary actuator, set the shaft to the end position, i.e. to the same position which single acting actuators reach through the spring load or which the air signal OUT2 of the positioner causes.
- Position the actuator shaft in such a way that the groove is at right angles to the longitudinal axis.



NOTICE

- The TZID rotating shaft can only be rotated in the direction of the indicating arrow on the shaft. There are no mechanical stops to limit the actuator movement. Improper mounting can damage the device and void warranty.
- When mounting the positioner, make sure that there is a loose fit between the adapter at the positioner and the actuator shaft. It must be possible to move the adapter manually within the range of 0.1...0.3 mm. If required, readjust the mounting bracket.

Before mounting the positioner:

- Determine the actuator's direction of rotation (counterclockwise or clockwise).
- Determine the mounting position (in parallel with the actuator or shifted by 90°).

Mounting TZID in parallel with an actuator turning counterclockwise

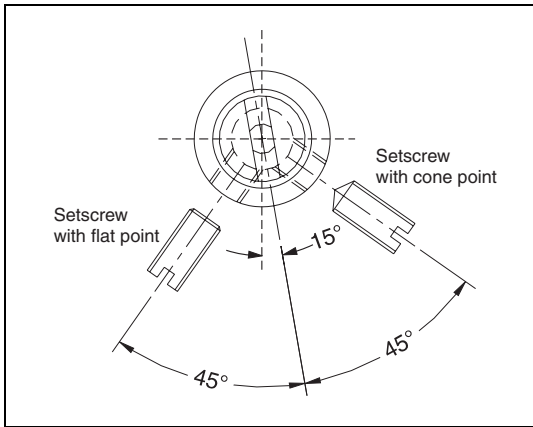

Fig. 8 Adapter position (factory setting)

The TZID positioner is prepared for this type of mounting when it is delivered. No adapter settings are required.

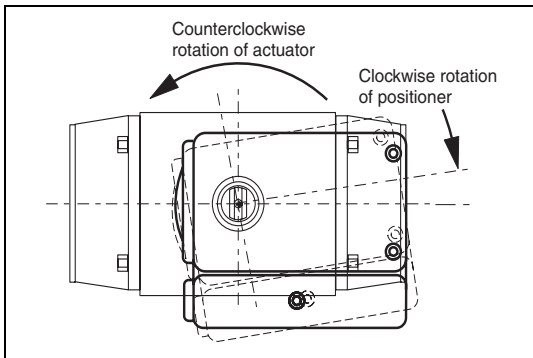
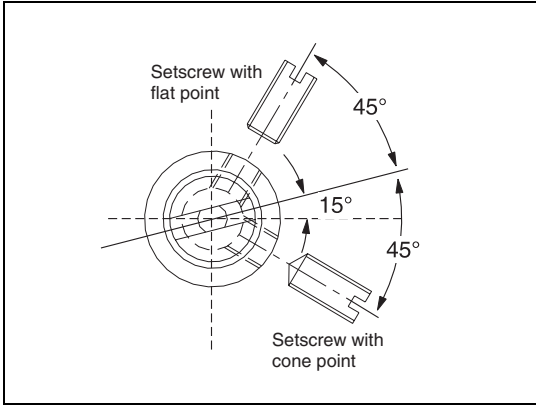

Fig. 9 Mounting TZID in parallel with an actuator turning counterclockwise

- Couple the positioner's adapter with the rotary actuator's shaft.
- Turn TZID **clockwise** by approx. 15° (see Fig. 9).
- Fasten TZID with screws.

Mounting TZID shifted by 90° to an actuator turning counterclockwise



- Undo the setscrews on the shaft adapter.
- Shift the adapter by 90°, as shown in Fig. 10.
- Re-fasten the setscrews.

Fig. 10 Adapter position (shifted by 90°)

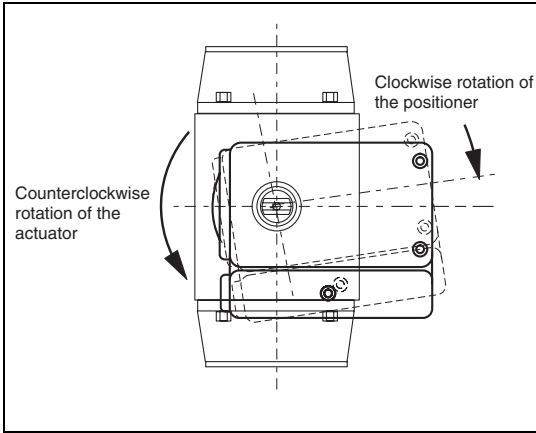

- Couple the positioner's adapter with the rotary actuator's shaft.
- Turn TZID **clockwise** by approx. 15° (siehe Fig. 11).
- Fasten TZID with screws.

Fig. 11 Mounting TZID to an actuator turning counterclockwise, shifted by 90°

Mounting TZID in parallel with an actuator turning clockwise

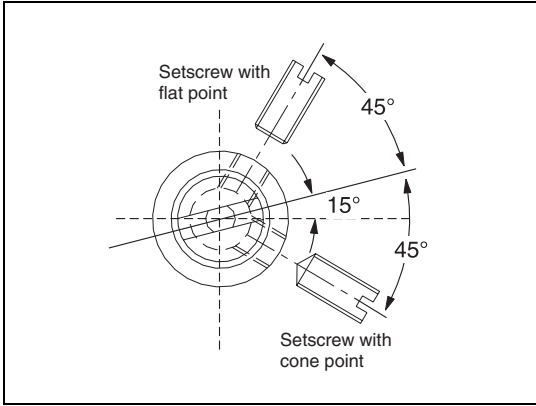

- Undo the setscrews on the shaft adapter.
- Shift the adapter by 90°, as shown in Fig. 12.
- Re-fasten the setscrews.

Fig. 12 Adapter position (shifted by 90°)

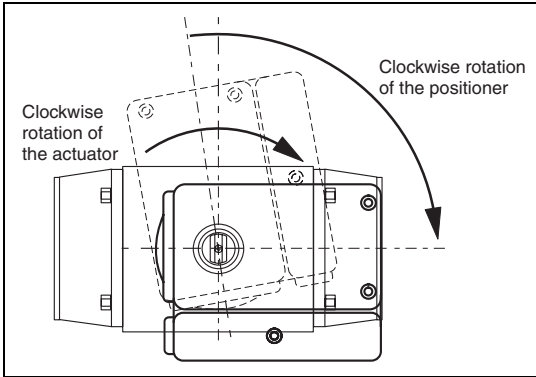

- Couple the positioner's adapter with the rotary actuator's shaft.
- Turn TZID **clockwise** by approx. 105° (see Fig. 13).
- Fasten TZID with screws.

Fig. 13 Mounting TZID in parallel with an actuator turning clockwise

Mounting TZID shifted by 90° to an actuator turning clockwise

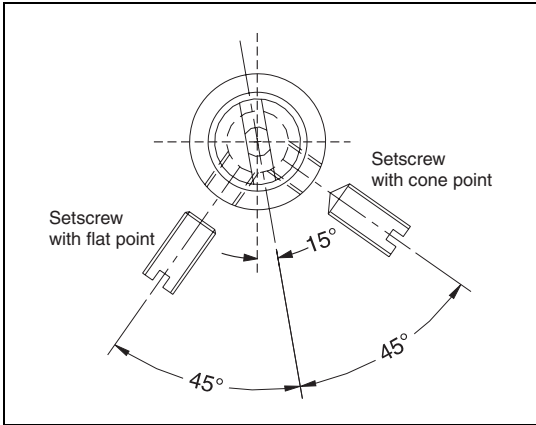

Fig. 14 Adapter position (factory setting)

The TZID positioner is prepared for this type of mounting when it is delivered. No adapter settings are required.

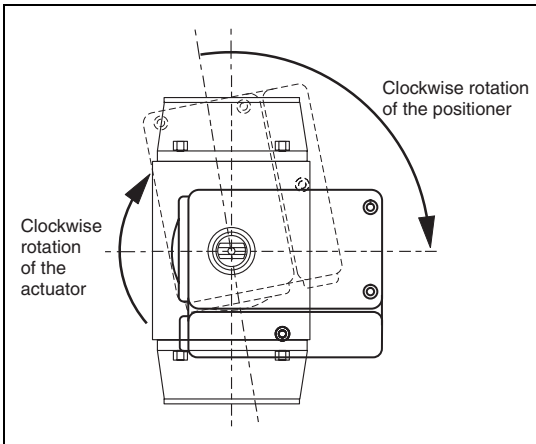

Fig. 15 Mounting TZID to an actuator turning clockwise, shifted by 90°

- Couple the positioner's adapter with the rotary actuator's shaft.
- Turn TZID **clockwise** by approx. **105°** (see Fig. 15).
- Fasten TZID with screws.

3.2 Pneumatic connection

3.2.1 Safety instructions



- Observe the accident prevention rules of the Employers Liability Insurance Association.
- Observe the safety instructions for the pneumatic actuator used. The actuator's high actuating power may cause injuries!



- Take suitable precautions to ensure that even in case of malfunctions the positioner's max. admissible operating pressure of 6 bar (90 psi) is not exceeded. Otherwise, the positioner and/or the actuator may be damaged.
- The positioner must be supplied with instrument air exempt from oil, water and dust according to DIN/ISO 8573-1, Class 3
 - Purity: max. particle size 5 μm , max. particle density 5 mg/m^3
 - Oil content: max. concentration 1 mg/m^3
 - Pressure dew point: maximum value 10 K below operating temp.

Before connecting the air pipes blow them out to remove dust, splinters and other particles.

3.2.2 Making the pneumatic connection

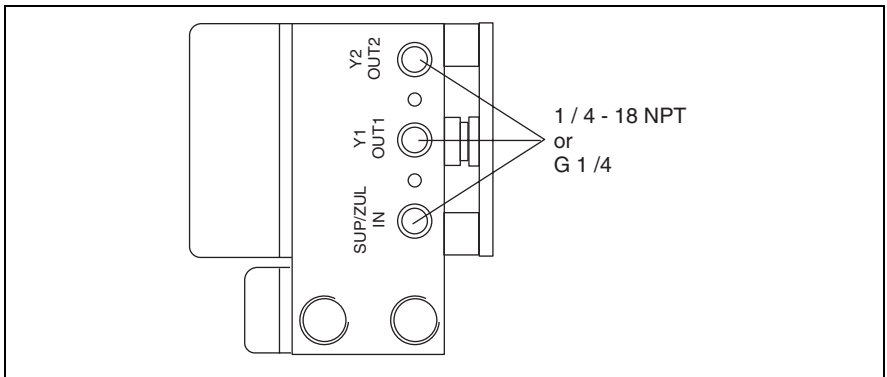

Fig. 16 Pneumatic connectors

All pneumatic connectors are on the right-hand side of the positioner. Threaded bores G 1/4 or 1/4-18 NPT, respectively, are provided for pneumatic connection. The positioner is labeled according to the type of thread. The corresponding screwed pipe connections have to be supplied by the customer. We recommend pipes with the dimension 6 x 1 mm for the pneumatic piping. Prior to connecting the pneumatic pipes always remove dust, splinters or similar particles by blowing the pipes out.

The amount of supply pressure has to be matched to the working pressure necessary for the actuation. The positioner's operating range is between 1.4 and 6 bar.

The connections have to be arranged, according to their marks, in the following way:

Mark	Connection piping
SUP/ZUL. IN	Air supply, pressure 1.4...6 bar (20...90 psi)
Y1/OUT1	Output pressure to actuator
Y2/OUT2	Output pressure, to actuator (second output, for double-acting actuators)

For double-acting actuators, connect the Y2/OUT2 output with the actuator chamber that provides for the same action as the return spring of single-acting actuators.

A pressure gauge block is available for indicating the supply air pressure and output pressure. Fasten the pressure gauge block to the side of the TZID positioner. Make sure that the O-ring seals are positioned properly to ensure tight fitting.

An optional filter regulator can be attached to the pressure gauge block. When attaching the filter regulator, make sure that the regulator housing is oriented vertically to ensure that condensed water is drained off.

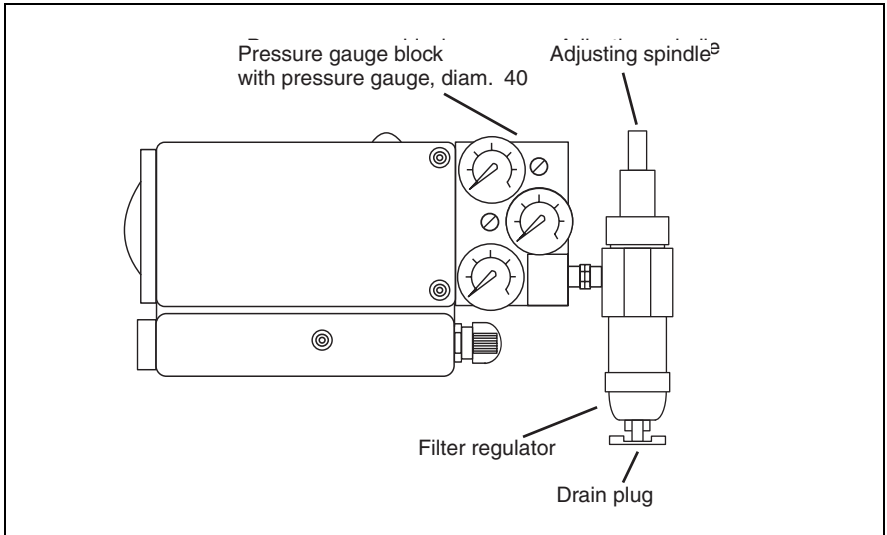

Fig. 17 TZID with pressure gauge block and filter regulator

3.3 Electrical connection

3.3.1 Safety instructions



- Observe the common VDE safety regulations and the accident prevention rules of the Employers Liability Insurance Association.
- Observe the common standards and safety regulations for the installation and operation of electrical systems.
- When connecting the device, observe all electrical specifications in these operating instructions or in the data sheet.
- For the electrical installation of explosion-protected devices, observe all standards, regulations and directives governing explosion protection and applicable for the construction and use of explosion-protected systems, especially the DIN/VDE directives, the directives for explosion protection (VDE 0165 or EN 60079), and the special requirements and specifications for your devices (see chapter "Certificates").
- Explosion-proof devices may only be supplied with safe extra-low voltage (SELV) according to EN 60 950.
- When using the positioner "intrinsically safe with flammable gas" observe the special conditions stipulated in the certificates.

3.3.2 General installation instructions



Observe the following instructions. They are essential to proper operation and functionality of the positioner.

General

- Do not expose the terminals to strain.
- Exclusively connect signal circuits with load-independent 4...20 mA current to terminals +11/-12.
- Make sure that the maximum current does not exceed 300 mA (150 mA for intrinsically safe devices) in case of a malfunction and 150 mA in case of polarity reversal.

Technical data

- When connecting the device, make sure that the electrical specifications and limits in the technical data section of this manual or in the data sheet are observed.

Electromagnetic interference

- Do not lay signal lines close to power lines. Power lines produce interference in their near vicinity, which may affect measured value transmission on the signal line.

3.3.3 Overview

Two threaded bore holes 1/2 - 14 NPT or M20 x 1.5 are available on the right-hand side as the cable entry into the case. One is equipped with a cable gland and in the other a pipe plug is mounted. In its standard version the TZID positioner is delivered with the cable gland already installed.

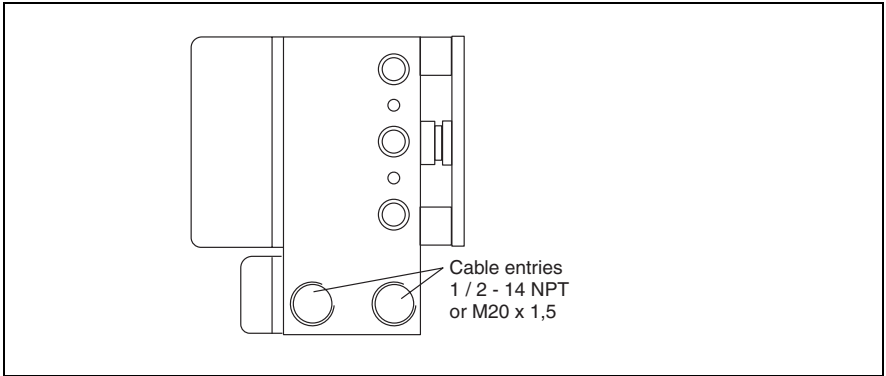

Fig. 18 Cable entries

The terminals have the following assignment:

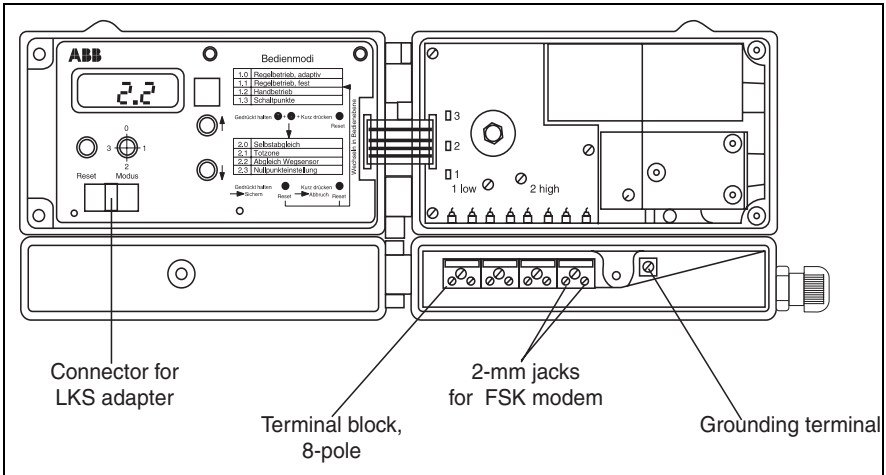

Fig. 19 Terminals

Connecting the cables to the terminals

A screw terminal block for a max. wire CSA of 2.5 mm² is located in the separate terminal box under the device. The required wiring efforts depend on the number of supplementary modules used. Refer to the rating plate or the catalog number for details.

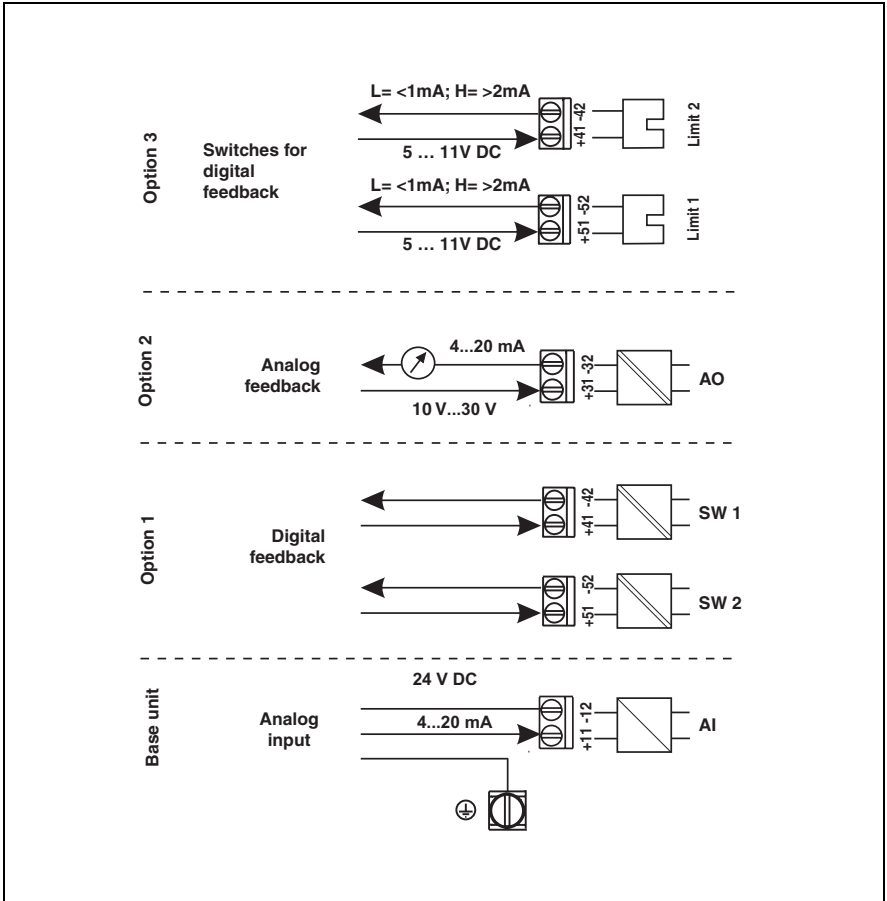

Fig. 20 Terminal assignment

3.4 Commissioning



CAUTION

- When commissioning the positioner, first switch on compressed air supply and only then apply the 4...20 mA current signal.
- Before commissioning the TZID positioner, read the necessary information about the operating elements on the display and operator panel and their functions.

In the commissioning phase, the positioner is configured, i.e. it is adapted electronically to the operational data of the actuators or control valves. Two ways are possible:

Commissioning the positioner locally using its operator panel

This method only requires little technical effort. The positioner must be supplied with a 4...20 mA current signal and with compressed air of 1.4...6 bar. Commissioning is in this case limited to adapting the positioner to the operational data of the actuator or control valve. Any adjustment that goes beyond this scope requires the method described below.

Commissioning the positioner remotely via a PC with special TZID software

Commissioning through the PC is done via the communication port and a special adapter. With this method, the full range of the positioner's adjustment and adaptation capabilities is available.

These operating instructions only describe commissioning via the built-in operator panel. Please refer to a separate document for the necessary information about commissioning the TZID via the communication port and a connected PC.

3.4.1 Adapting the positioner to the actuator

The positioner can be adapted to the operational data of the actuator in the "Autostroke" mode. In this operating mode, a program is started which determines all relevant data and transmits them to the positioner. No manual adjustment is required. Refer to the section about operating level 2, "Display 2.0 = Autostroke" for details about the Autostroke.

Successful self-adaptation using the Autostroke function requires that the angle of rotation for position feedback is within the permissible range. The range that is actually used for position feedback can be scanned electronically. Refer to the section about operating level 2, "Display 2.2 = Position sensor span" for details. Based on a displayable range of 0...100 %, the following requirements must be met:

- Angle of rotation > 2 % and < 98 %
- Range > 20 % (High-Low)

If these requirements are not met, the mechanical link converting the movement into an angle of rotation must be readjusted.

If Autostroke is initialized although the requirements listed above are not met, Autostroke is aborted automatically and the respective error code (see Appendix) is shown in the display.

3.4.2 Adjusting the tolerance band

The value of the effective tolerance band depends upon the air capacity and the friction of the actuator (control valve). The span is from 0.3 % to 10.0 % (referred to a movement of 100 %). The smallest possible value is determined by Autostroke, checked while the positioner is running in “adaptive” control mode, and corrected if required. If it is necessary to improve stability, you can set higher values by manual data entry via the operator panel. For details refer to the section about operating level 2, “Display 2.1 = Man. dead band adjustment”.

3.4.3 Adjusting the valve action

The positioner works with two types of valve action:

Direct: Signal 4...20 mA, position 0...100 %

Reverse: Signal 20...4 mA, position 0...100 %

The valve action can be adjusted on the operator panel as described below (factory setting defaults to “direct action”):

Changing over from direct to reverse action

- Call up operating level 2, display 2.0 = Autostroke.
- Press and **hold** the “Down” push button.
- **Wait** until the displayed countdown from 3 to 0 is finished, **then release** the “Down” button.
- Press and **hold** the “Down” button again.
- **Wait** until the displayed countdown from 3 to 0 is finished, **then release** the “Down” button.

The display shows the code “P31”, which is flashing in the beginning and then changes over to a permanent display. After another 2 seconds, it is replaced with a flashing colon. Save the newly set parameters in the non-volatile memory as described in section “Exiting operating level 2”.

Changing over from reverse to direct action

The procedure is the same as described above. However, in this case you must press the “Up” button instead of the “Down button”. The code shown in the display is “P32” instead of “P31”.

3.4.4 Setting parameters for current operation

Normally, “Controlling adaptive” at operating level 1 is selected for current operation. It is only necessary to select “Controlling fixed” if the positioner is working unstable in adaptive mode.

3.4.5 Adjusting low and high alarm limits (supplem. modules for digital feedback)

For positioners with a supplementary module for “digital feedback“ the low and high alarm limits are adjusted electronically. Adjustment is only possible after the positioner has been mounted to the actuator and after an Autostroke has been performed. For details refer to the section about operating level 1, “Display 3 = Setting of switches“.

3.4.6 Adjusting low and high alarm limits (supplementary “mechanical kit for digital feedback“)

For positioners with the supplementary module “mechanical kit for digital feedback“ the low and high alarm limits are set mechanically. Adjustment is only possible after the positioner has been mounted to the actuator and after an Autostroke has been performed. Observe the direction of action of the “NC” and “NO” switches.

Direction of action NC Control lug **out of** proximity switch
-> state 1 (control current > 3 mA)

Control lug **within** proximity switch
-> state 0 (control current < 1 mA)

Direction of action NO Control lug **out of** proximity switch
-> state 0 (control current < 1 mA)

Control lug **within** proximity switch
-> state 1 (control current > 3 mA)

The TZID positioner has two screws for alarm limit adjustment (see Fig. 21). The screws are protected against unwanted turning. To adjust the alarm limits, push in the adjustment screws with a screw driver to enable snapping in. Before making the mechanical adjustment, set the actuator manually to the desired switching position (see section about operating level 1, “Manual control”). The low and the high alarm limit have to be adjusted separately.

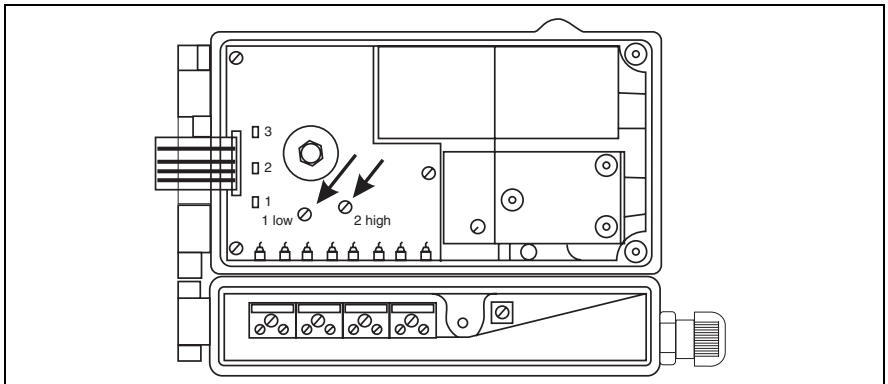

Fig. 21 **Adjusting alarm limits**

3.4.7 Restoring the factory setting

Positioners adapted to special operating data can be reset to the factory setting. This may become necessary if, for example, an already configured positioner is mounted to another actuator.

Proceed as described below to restore the factory setting (requires Software Revision 4.5 or higher):

- Select operating level 1, "Manual control"
- **Press and hold** the "Reset" push button. **Wait** until the displayed countdown from 10 to 0 is terminated.
- **Release** the "Reset" button. A flashing colon appears in the display.
- **Press and hold** "Reset" again. **Wait** until the displayed countdown from 10 to 0 is terminated (factory setting will be saved in the non-volatile memory).
- **Release** the "Reset" button.

3.4.8 Performing the Autostroke

The Autostroke function is started via the operator panel (see section "Display and operator panel"). The individual steps and, thus, the progress is indicated on the display. The following is a reference list.

Display	Autostroking function
10	Fully depressurize the actuator.
11	Save position of fully depressurized actuator.
12	Determine and save resolution (A/D conversion).
20	Fully pressurize actuator.
21	Save position of fully pressurized actuator.
30	Prepare determination of positioning time
31	Set valve from 100 % to 0 % position. Measure and save the positioning time.
32	Set valve from 0 % to 100 % position. Measure and save the positioning time.
40	Determine and save the deadband (smallest possible value). Determine and save PD control parameters for rapid control of deviations > deadband.
50 -120	Determine and save PID control parameters for fine adjustment of control deviations < deadband.
200	Autostroke completed.

This list applies to a full Autostroke. When using a PC with TZID software, you can also execute a partial Autostroke, as listed below:

- Stops only (steps 10 to 32/200)
- Parameters only (steps 40 to 120/200)
- Zero only (refer to the list below for the steps and their meaning¹)

Display	Autostroking function
10	Move actuator to closed position.
11	Save closed position.
12	Determine and save resolution (A/D conversion)
13	Zero adjustment
200	Autostroke completed

1. A “Zero” Autostroke requires that the range has been determined before using the TZID software.

4 Display and operator panel

The TZID positioner's display and operator panel is accommodated in the hinged cover (siehe Fig. 22), requiring that the case is opened for operation.

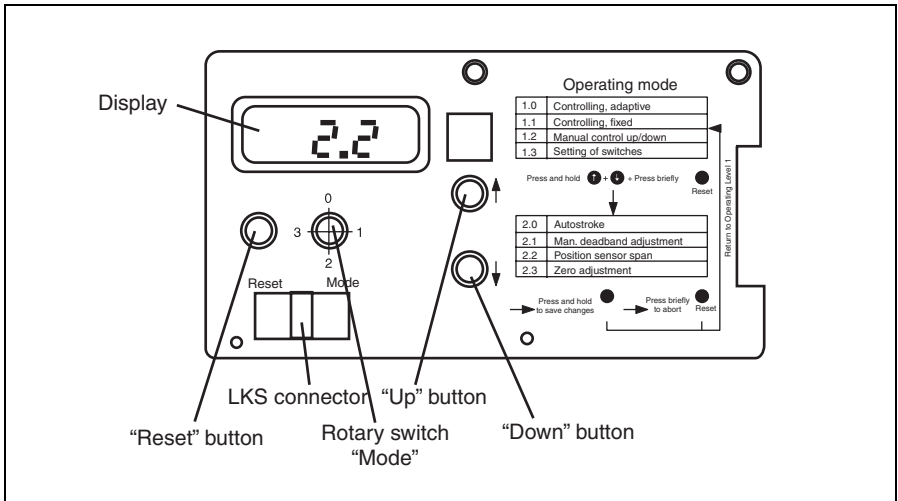

Fig. 22 Display and operator panel

The display and operator panel is designed for two tasks and, therefore, provides two operating levels:

Operating level 1 Monitoring and special adjustment while the system is running.

Operating level 2 Commissioning and configuration (basic functions)

If troubles occur during operation or commissioning, an error code appears on the display. Refer to the Appendix for a reference list of the error codes with their reasons and suggestions for help. When the positioner is started, the software revision level (5.0 at the time when this document is prepared) is shown on the display for a short time.

4.1 Operating level 1

When an input signal > 3.6 mA is applied, the positioner starts up at operating level 1. Four operating modes can be selected through manual control. TZID has a rotary switch with positions 0, 1, 2 and 3.

Display 0 = Controlling adaptive

This operating mode is usually selected. “Adaptive” means that the controller permanently adapts itself in an optimal way to the operating conditions by using an “AUTO-tune” function.

The display shows a position between 0 and 100 %, where “0” indicates that the valve is closed, and “100” shows that the valve is fully open. The display assignment is adjustable (adjustment parameter).

Newly adapted values are automatically saved in the non-volatile memory at intervals. Data storage, which only takes a short time, is indicated by the two characters “EE” shown by the display.

Display 1 = Controlling fixed

This operating mode should only be selected if “adaptive” control does not yield a stable control of the position until reaching the set point.

“Controlling fixed” means that the values determined by Autostroke are no longer readjusted automatically. The display of the position as a percentage between 0 and 100 % is the same as for “adaptive” control.

Display 2 = Manual control

In this mode the valve can be adjusted manually by pressing the “Up” (towards 100 %) and “Down” (towards 0 %) buttons. Pressing both buttons simultaneously will cause rapid opening/closing of the valve. The order in which the buttons are pressed defines whether the valve is opened or closed.

The LC display shows the manually set position between 0...100 %.



- The position will not be readjusted if air escapes due to a leakage.
- The configured stroke limits and adjusted speeds are not active in manual mode.

IMPORTANT

Display 3 = Setting of switches (alarm limits)

This mode allows to display and adjust stroke-dependent alarm limits, provided that the supplementary module for digital feedback is plugged into the positioner. Without the module, this function is not active.

Displaying the alarm limits

Press briefly the “Up” (high alarm limit) or “Down” (low alarm limit) button.

The alarm limits will be shown for around 1 second instead of the current position between 0 and 100 %.

Adjusting new alarm limits

First select operating mode “Display 2 = Manual control” at the operator panel and then set the actuator manually to the position of the desired alarm limit.

Then select operating mode “Display 3 = Alarm limits”. Subsequently press the “Up” (high alarm limit) or “Down” (low alarm limit) button and hold it until the displayed countdown from 3 to 0 is terminated.

With this procedure you can adjust and save both alarm limits, one after the other. If you still hold the “Up” or “Down” button after the countdown is finished, “P21” (for the low alarm limit) or “P22” (for the high alarm limit) is shown by the display for a short time. Then the alarm limit in %, referred to the stroke of 0...100 %, is shown.

4.2 Operating level 2

You can only access and exit operating level 2 for configuration through special manual entries.

Calling up operating level 2

1. Press and **hold** “Up” and “Down” buttons **simultaneously**.
2. Press “Reset” **briefly** and **release**.
3. **Wait** until displayed countdown from 3 to 0 is finished, then **release** “Up” and “Down” buttons.

The display first shows the operating mode (e.g. 2.2) and then a flashing arrow (siehe Fig. 23).

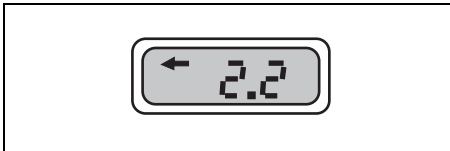

Fig. 23 Flashing arrow in the display

The arrow indicates that a change-over to operating level 2 is in progress.

If the positioner was working in the mode “Controlling adaptive”, the newly determined values are saved. This is indicated by the characters “EE” shown on the display.

Exiting operating level 2

1. Press “Reset” **briefly** and **release**.
Newly determined values are rejected.
This is indicated by “EEL” shown on the display.
Press “Reset” briefly again to return completely to operating level 1.
2. Press and **hold** “Reset”.
Wait until displayed countdown from 3 to 0 is terminated, then **release** “Reset”.
You are returned to operating level 1.
All new parameters are saved in the non-volatile memory.
This is indicated by “EEP” shown on the display.

A flashing colon appears in the display if there are values which have not yet been saved in the non-volatile memory (see Fig. 24).

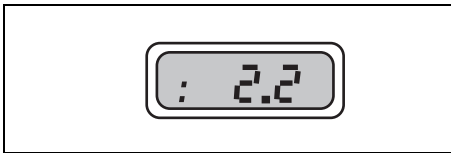

Fig. 24 Colon in the display

After calling up operating level 2 you can also select four operating modes (0 - 1 - 2 - 3).

Display 2.0 = Autostroke

In “Autostroke” mode the positioner adapts itself automatically to the following operating parameters:

- Actuator action
(direction of action with compressed air)
- Travel of the actuator/valve
(from stop 0 % to stop 100 %)
- Positioning time for both directions
(pressurizing and depressurizing the actuator)
- Control parameters for stable position control
- OFFSET for the I/P module

- i**
- IMPORTANT**
- Normal control is interrupted while the Autstroke is in progress.
 - The Autstroke function can be terminated any time by pressing the “Reset” button.
 - If unpermissible values are determined, the Autstroke is automatically aborted and an error code is shown by the display (see Appendix)

When this mode is called up, “2.0” is shown in the display.

To

To start the Autostroke, proceed as follows

1. **Press and hold** the “Up” and “Down” buttons **simultaneously**
2. **Wait** until the displayed countdown from 3 to 0 is terminated.
3. Release the “Up” and “Down” buttons.

The progress of the Autostroke is continuously indicated by codes that occur in the display.

Display 2.1 = Tolerance band

In this mode the positioner can be adapted to the dynamic and the hysteresis of the actuator. When this mode is called up, the display first shows the mode number (2.1) for around 1 second, and then the currently active value.

The adjustable range is between 0.30...10.00 %, the factory setting is 0.3 %. Press the “Up” or “Down” button to change the setting. Note that the adjustment is done on line, i.e. the settings are immediately taken over.

The smallest tolerance band value is determined during the Autostroke. Via the operator panel only higher values can be set, if this should be required to improve stability.

Display 2.2 = Position sensor span

In this mode the actually used angle of rotation or angular range is scanned. When this mode is called up, the display first shows the mode number (2.2) and then the determined value.

Normally, the default angle of rotation 0...100 % is indicated. Do not confound this reading with the 0...100 % display of the stroke. The angle of rotation in % for a stroke of 0 % and of 100 % can be seen by pressing the “Up” and “Down” buttons. Press both buttons together for a quick run. Note that the order in which the buttons are pressed determines the direction.

The scanned values result from the mechanical linkage and the transmission to the shaft for position feedback.

Display 2.3 = Zero adjustment

In this mode a zero adjustment between the 4...20mA input signal and the 0...100 % stroke can be performed. When this mode is called up, the display first shows the mode number (2.3) for around 1 second. Then the position controlled with the currently applied input signal is shown.

Press the “Up” or “Down” button to set the deviation to “0”. Deviation “0” means that the positioning signal, e.g. 50 % (12 mA) will exactly set the actuator to a position of 50 %. The adjustment takes place on line, i.e. the adjusted values are immediately active.

i **IMPORTANT**

- When you are returning to operating level 1, you can select either “save non-volatile” or “no save”. Selecting “save non-volatile” will save all parameters permanently, even if the settings have been made in different modes. If, however, you choose “no save”, none of the parameter settings made will be saved.

5 Maintenance



WARNING

Do not make any changes to devices with explosion protection.



IMPORTANT

If you should modify or manipulate the electronics of a positioner without explosion protection, the positioner's warranty will expire immediately.

The TZID positioner is virtually maintenance-free.

We recommend to check the control position periodically for conformity with the tolerance limit.

If the optional filter regulator is installed, it collects condensed water which must be drained off.

Additionally, the integrated air filter must be checked for dirt accumulation on a regular basis. If required, it must be replaced.

Under certain conditions it may become necessary to replace the pneumatic output unit.

5.1 Functional test/Readjustment

An overall functional test can only be carried out via the communication port and a PC with special TZID software.

Otherwise, only a simple visual check can be performed. Due to the electronic function no mechanical adjustment is possible. During operation, the positioner's zero can be checked and readjusted if required. When the system is switched off, an Autostroke can be performed to re-adapt the positioner to the operating conditions.

5.2 Checking/replacing the filter regulator

If the optional filter regulator is installed, it collects condensed water which must be drained off at intervals (by opening the drain screw of the filter housing). The intervals depend upon the air supply quality. Additionally, the filter element (sintered bronze, 40 µm) may require cleaning or replacement, depending on the air supply quality, too.

5.3 Checking the air filter in the positioner



CAUTION

Prior to working on the air filter, always switch off compressed air supply.

To ensure trouble-free operation make sure that the supply air is free of oil, water and dust in accordance with DIN/ISO 8573-1 (purity and oil content acc. to class 3, pressure dew point 10 K below operating temperature).

If the air supplied to the positioner is not clean and dry as specified, the built-in textile filter can protect the air nozzles and throttles against pollution to a certain degree. However, the filter capacity only allows for collecting residual dirt for a short time. If polluted air is supplied for a longer time, the filter is clogged with dirt.

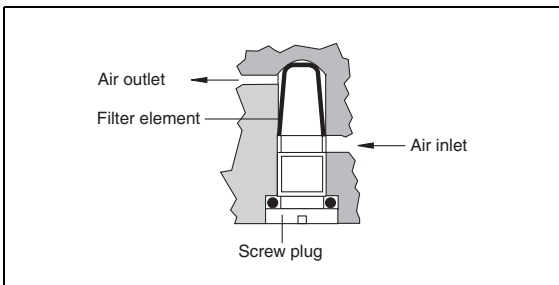

Fig. 25 Air filter

Proceed as follows:

1. Switch off compressed air supply.
2. Remove the screw plug retaining the air filter.
3. Remove the filter element using tweezers and check the degree of pollution. Replace the filter element if required. Spare filter elements can be ordered from ABB under catalog number 7942511.
4. Insert the filter.
5. Fasten the screw plug again.
6. Switch on compressed air supply.

After filter element replacement the positioner will immediately be operational again and does not require any additional steps like, for example, readjustment.

5.4 Replacing the pneumatic output unit



CAUTION

- Prior to starting any work on the pneumatic output unit, always switch off compressed air supply.
- When putting the pneumatic output unit back in place, make sure that all gaskets are present and are positioned properly.



A change-over to a pneumatic output unit with other functionality is only possible with Rev. 5.00 and higher.

IMPORTANT

The pneumatic output unit can be replaced. The replacement may become necessary for one of the following reasons:

- Considerable pollution with dirt or oil due to supply with insufficiently cleaned air.
- Change of the output from single-acting to double-acting and vice versa.
- Change of the safe state from “fail safe” to “fail in place” or vice versa.

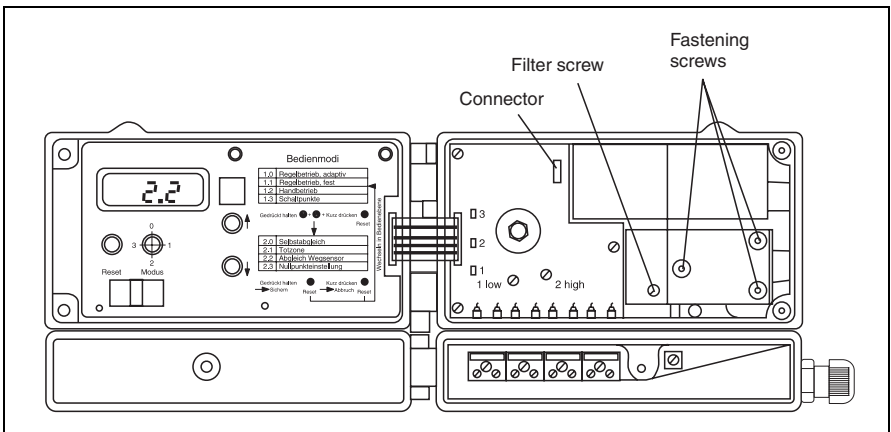

Fig. 26 Replacing the pneumatic output unit

Proceed as follows:

1. Switch off compressed air supply.
2. Disconnect the plug of the old output unit.
3. Undo the three fastening screws (Torx-head) and remove the old output unit.
4. Insert the new output unit. Make sure that the gasket with its cutting is positioned correctly.
5. Re-insert the Torx-head screws and torque them to 350 Ncm (31 in-lbs).
6. Connect the plug. Make sure that the plug snaps in properly. The connector is protected against polarity reversal.
7. Switch on compressed air supply.

6 Technical data

6.1 Basic model

Input

Range 4...20 mA (nominal range)
Split-ranges configurable betw. 20 and 100 % of the nominal range

Two-wire technology

Load voltage 9.8 V DC non-Ex model
9.8 V DC with explosion protection type Exd
10.8 V DC intrinsically safe
Impedance 490 ohms with 20 mA and 9.8 V DC
540 ohms with 20 mA and 10.8 V DC

Output

Range

0...6 bar (0...90 psi)

Air capacity

at supply pressure of 1.4 bar (20 psi)
5.5 kg/h = 4.5 Nm³/h = 2.5 scfm
at supply pressure of 6 bar (90 psi)
13 kg/h = 11 Nm³/h = 6.5 scfm
(Booster available on request)

Function

for single or double acting actuators,
air is vented from actuator or actuator is blocked if input signal < 3.9 mA

Shut-off point

Setable to 0...20 % of signal
(when the value falls below the set value, the positioner immediately sets the valve to the closed position)

Travel

Angle of rotation

60 ° nominal range for attachment to linear actuators in acc. with DIN/IEC 534
120 ° nominal range for attachment to rotary actuators in acc. with VDI/VDE 3845
Used range is 25...100 % of nominal range

Adjusted speed

Can be adjusted separately for each direction as a 0...200 second ramp

Time-out monitoring

Range 0...200 sec
(monitoring parameter for control until the deviation reaches the tolerance band)

Travel limit

Min. and max. limits, freely configurable within 0...100 % of total travel

Air supply

Instrument air

free of oil, water and dust to DIN/IEC 770

Supply pressure

1.4...6 bar (20...90 psi)

NOTICE: Do not exceed the max. operating pressure of the actuator!

Air consumption

< 0.03 kg/h / 0.025 scfm (independent of supply pressure)

Transmission data and influences

Effective direction (output signal or pressure in actuator)

Increasing: increasing signal 4...20 mA
 increasing pressure OUT1 in the actuator
Decreasing: increasing signal 4...20 mA
 decreasing pressure OUT1 in the actuator

Valve action

Direct: signal 4...20 mA = position 0...100 %
Reverse: signal 20...4 mA = position 0...100 %

Characteristic curve (travel = f{signal})

linear,
equal percentage 1:25 or 1:50 or 25:1 or 50:1,
and freely configurable with 20 reference points

Characteristic deviation

≤ 0.5 %

Tolerance band (sensitivity)

0.3...10 %, adjustable

Resolution (A/D conversion)

> 8,000 steps

Sample rate

20 milliseconds

Influence of ambient temperature

≤ 0.5 % for every 10 °C change in temperature

Influence of vibration

≤ 1 % up to 10 g and 80 Hz

Seismic requirements

Meets requirements of DIN/IEC 68-3-3 Class III for strong and strongest earthquakes

Influence of mounting orientation

No effect

EMC

Meets the requirements of the EMC Directive 89/336/EEC as of May 1989

CE Mark

Meets the EC regulation for the CE conformity mark

Communication port

Connector for LKS (local communication interface) adapter (standard)
FSK module for frequency-modulated tapping (optional)

Environmental capabilities

Climate classe

GPF to DIN 40040

Ambient temperature

-40 °C to +85 °C for operation, storage and transport

-25 °C to +85 °C when using proximity switch SJ2-S1N (NO)

Explosion protection



The values indicated here have been taken out of the respective approval certificates. The specifications and supplements according to the certificates (see chapter "Certificates") are binding and must be observed.

WARNING

ATEX



II 2G EEx ia II C T6

Examination certificate

TÜV 02 ATEX 1830 X

Type:

Intrinsically safe

Device class:

II 2G (EEx ia IIC)

Temperature class:

T4, T5, T6

Permissible ambient temp.: T4: $-40\text{ °C} \leq T_{\text{amb.}} \leq 85\text{ °C}$

T5: $-40\text{ °C} \leq T_{\text{amb.}} \leq 50\text{ °C}$

T6: $-40\text{ °C} \leq T_{\text{amb.}} \leq 35\text{ °C}$

ATEX



II 3G EEx n A II T6

Examination certificate

TÜV 02 ATEX 1867 X

Type:

Explosion-proof (Zone 2)

Device class:

II 3G (EEx n A II)

Temperature class:

T4, T5, T6

Permissible ambient temp.: T4: $-40\text{ °C} \leq T_{\text{amb.}} \leq 85\text{ °C}$

T5: $-40\text{ °C} \leq T_{\text{amb.}} \leq 65\text{ °C}$

T6: $-40\text{ °C} \leq T_{\text{amb.}} \leq 50\text{ °C}$

FM

Intrinsically safe

CL I-II-III, Div 1, Grp A-B-C-D-E-F-G

Non-incendive

CL I-II-III, Div 2, Grp A-B-C-D-E-F-G

Explosion-proof

CL I-II-III, Div 1, Grp B-C-D-E-F-G

CSA

Intrinsically safe; Enclosure 4X; T4, max. 85°C

CL I, Div. 1, Grp. A-B-C-D

CL II, Div. 1, Grp. E-F-G

CL III, Div. 1

Non-incendive; Enclosure 4X, max. 85°C

CL I, Div. 2, Grp. A-B-C-D

CL II, Div. 2, Grp. E-F-G

CL III

Case

Material/Protections

Aluminum, protection class IP 65 / NEMA 4X

Case varnished black, RAL 9005, matt,

Electrostatic dipping varnish with epoxy resin, thick-film

Stainless steel 1.4581, protection class IP 65 / NEMA 4X

Electrical connections

Screw terminals, internal, for 2.5 mm²

NOTICE: Do not expose the terminals to strain!

Cable entry:

Threaded holes (depending on model and order)

1/2-14 NPT or M20 x 1,5

TZID is delivered with the cable gland already installed.

Pneumatic connections

Threaded holes G 1/4 or 1/4-18 NPT

Weight

2.9 kg (TZID with aluminum case)

5.6 kg (TZID with stainless steel case)

Mounting orientation

as required, but no overhead mounting

Dimensions

See dimensional drawings in data sheet 10/18-0.20 DE

6.2 Options

Supplementary module for analog feedback

Signal range 4...20 mA (split ranges configurable)

Two-wire circuitry, power supply 10...30 V DC

Standard or intrinsically safe version

Direct or reverse valve action (configurable)

Characteristic deviation < 1 %

(Whether the module is to be used for alarm reporting and whether the output is to be modulated to 3.5 or 21.5 mA can be configured.)

Supplementary module for digital feedback

3 switches for current circuits in accordance with DIN 19234

Control voltage 8...25 V DC

Signal current < 1.2 mA Switching state logical "0"

Signal current > 2.1 mA Switching state logical "1"

Direction of action: Normally logical "0" or logical "1" (configurable)

Model standard or intrinsically safe

Switch assignment: 1 switch for alarms

2 switches for min. or max. position
(adjustable between 0 and 100 %)

Mechanical kit for digital position feedback

2 proximity switches for current circuits acc. to DIN 19234

Control voltage 5...25 V DC

Signal current < 1 mA switching state logical "0"

Signal current > 3 mA switching state logical "1"

Model standard or intrinsically safe¹

For min. or max. position,

Limits adjustable between 0 and 100 %

(Function independent of the positioner software and electronics)

Direction of action (logical state):

Proximity switch	Position			
	< Lim. 1	> Lim. 1	< Lim. 2	> Lim. 2
SJ2-SN (NC)	0	1	1	0
SJ2-S1N (NO)	1	0	0	1



CAUTION

When using proximity switch type SJ2-S1N (NO) the TZIDC positioner may be exposed to an ambient temperature of -25 °C ... +85 °C, only.

1. ATEX EEx ia IIC T1...T6

Attachment material

Attachment kit for linear actuators, stroke 10...85 mm
(lateral attachment to DIN/IEC 534 / Namur)

Lever 170 mm for linear actuators, stroke 10...150 mm

Attachment bracket for rotary actuators 90 °
Attachment to VDI/VDE 3845, dim. A/B = 80/20 mm
= 80/30 mm
= 130/30 mm
= 130/50 mm

Attachment kit for actuator-specific attachment available on request

Pressure gauges for supply pressure and output pressure

Plastic or stainless steel case, Ø 40 mm

Supply pressure range 0...10 bar/0...140 psi

Output pressure range 0...10 bar/0...140 psi
or 0.....4 bar/0.....60 psi

With connection block and attachment material for TZID

Connection block made of aluminum varnished black or of stainless steel.

Filter regulator with attachment material

All-metal version, brass, varnished black

Bronze filter element, 40 µm, with condensate drain

Max. pre-pressure 16 bar, output pressure adjustable to 1.4...6 bar

PC adapter for communication

LCI adapter for LKS connector on TZID

FSK modem for frequency-modulated tapping

1 Certificates



Translation

(1) EC TYPE-EXAMINATION CERTIFICATE

(2) Equipment or protective system intended for use in potentially explosive atmospheres - **Directive 94/9/EC**



(3) EC-Type Examination Certificate Number

TÜV 02 ATEX 1830 X

(4) Equipment: Positioner TZID type DOC 900920 resp. type DOC 900929

(5) Manufacturer: ABB Automation Products GmbH

(6) Address: Schillerstrasse 72
D-32425 Minden

(7) This equipment or protective system and any acceptable variation thereto is specified in the schedule to this certificate and the documents therein referred to.

(8) The TÜV NORD CERT GmbH & Co. KG, TÜV CERT-Certification Body, notified body number N° 0032 in accordance with Article 9 of the Council Directive of the EC of March 23, 1994 (94/9/EC), certifies that this equipment or protective system has been found to comply with the Essential Health and Safety Requirements relating to the design and construction of equipment and protective systems intended for use in potentially explosive atmospheres given in Annex II to the Directive.

The examination and test results are recorded in the confidential report N° 02 YEX 165344.

(9) Compliance with the Essential Health and Safety Requirements has been assured by compliance with:

EN 50 014: 1997

EN 50 020: 1994

(10) If the sign "X" is placed after the certificate number, it indicates that the equipment or protective system is subject to special conditions for safe use specified in the schedule to this certificate.

(11) This EC-type examination certificate relates only to the design, examination and tests of the specified equipment in accordance to the Directive 94/9/EC. Further requirements of the Directive apply to the manufacturing process and supply of this equipment. These are not covered by this certificate.

(12) The marking of the equipment or protective system must include the following:

II 2 G EEx ia IIC T6

TÜV NORD CERT GmbH & Co. KG
TÜV CERT-Certification Body
Am TÜV 1
D-30519 Hannover
Tel.: 0511 986-1470
Fax: 0511 986-2555

Hanover, 2002-09-12

Head of the
Certification Body



(13)

SCHEDULE

(14) **EC-TYPE EXAMINATION CERTIFICATE N° TÜV 02 ATEX 1830 X**

(15) Description of equipment

The positioner TZID type DOC 900920 resp. type DOC 900929 is used for the control resp. closed loop control of pneumatically driven valves using an impressed current of 4 to 20 mA.

The permissible ambient temperature range in dependence on the temperature class has to be taken from the following table:

Temperatureclass	Ambient temperature range
T4	- 40 °C to + 85 °C
T5	- 40 °C to + 50 °C
T6	- 40 °C to + 35 °C

Electrical data

Signal- and supply circuit
(terminal +11 and -12)

in type of protection „Intrinsic Safety“ EEx ia IIC
only for the connection to a certified intrinsically safe circuits

Maximum values:

$U_i = 30 \text{ V}$
 $I_i = 150 \text{ mA}$
 $P_i = 1,1 \text{ W}$
 $L_i = 54 \mu\text{H}$
 $C_i = 7 \text{ nF}$

Extension typ 1 (limiting values)

Signal- and supply circuit
(terminal +45/+31 and -44/-32
resp. +51 and -52
resp. +41 and -42)

in type of protection „Intrinsic Safety“ EEx ia IIC
only for the connection to a certified intrinsically safe circuits

Maximum values:

$U_i = 25 \text{ V}$
 $I_i = 203 \text{ mA}$
 $P_i = 1,5 \text{ W}$
 $L_i = 54 \mu\text{H}$
 $C_i = 7 \text{ nF}$

Extension type 2 (position feed back)

Signal- and supply circuit
(terminal +45/+31 and -44/-32)

in type of protection „Intrinsic Safety“ EEx ia IIC
only for the connection to a certified intrinsically safe circuits

Maximum values:

$U_i = 30 \text{ V}$
 $I_i = 170 \text{ mA}$
 $P_i = 1,275 \text{ W}$
 $L_i = 54 \mu\text{H}$
 $C_i = 12 \text{ nF}$



Extension type 3 (mechanical digital position feed back)

Mechanical digital feed back
(terminals Limit1 +51, -52
resp. Limit2 +41, -42)

Maximum values see EC-type examination certificate
No. PTB 00 ATEX 2049 X

(16) Test documents are listed in the test report No.: 02 YEX 165344.

(17) Special conditions for safe use

Positioner TZID type DOC 900920

The positioner has to be erected in such a way that at least the degree of protection of IP20 according to IEC 60529 is met.

The connection to the "local communication interface" (LKS) is solely allowed outside of the hazardous explosive area.

Positioner TZID type DOC 900929

The positioner has to be erected outdoors when operated with combustible gas.

The supplied gas must be kept free of air or oxygen in such a way that no explosive atmosphere emerges.

The exhausted gas must always be led outwards.

The connection to the "local communication interface" (LKS) is solely allowed outside of the hazardous explosive area.

(18) Essential Health and Safety Requirements

no additional ones



Translation

1. SUPPLEMENT to

EC-TYPE EXAMINATION CERTIFICATE No. TÜV 02 ATEX 1830 X

of the company: ABB Automation Products GmbH
Schillerstraße 72
D-32425 Minden

When operated with combustible gases the Positioner TZID type DOC 900929 may be installed outdoors resp. indoors when sufficient ventilation is given (see 17 „Special conditions for safe use“).

All other data apply unchanged.

(16) The test documents are listed in the test report N° 04YEX551065.

(17) Special conditions for safe use

When operated with combustible gases the Positioner TZID has to be installed outdoors resp. indoors when sufficient ventilation is given.

The supplied gas has to be kept free of air or oxygen so that it cannot form an explosive atmosphere.

The exhaust gases must always be exhausted outside.

The "Local Interface for Communication" (LKS) must only be used outside of the explosive hazardous area.

(18) Essential Health and Safety Requirements
no additional ones

TÜV NORD CERT GmbH & Co. KG
TÜV CERT-Certification Body
Am TÜV 1
D-30519 Hannover
Tel.: 0511 986-1470
Fax: 0511 986-2555

Hanover, 2004-07-05

Head of the
Certification Body



Translation

STATEMENT OF CONFORMITY

- (1)
- (2) Equipment or Protective System intended for use in potentially explosive atmospheres - **Directive 94/9/EC**
- (3) Test certificate number



TÜV 02 ATEX 1867 X

- (4) Equipment: Positioner TZID type Doc 900920
- (5) Manufacturer: ABB Automation Products GmbH
- (6) Address: Schillerstraße 72
D-32425 Minden
- (7) This equipment and any acceptable variation thereto is specified in the schedule to this certificate and the documents therein referred to.
- (8) The TÜV NORD CERT GmbH & Co. KG, TÜV CERT-Certification Body, notified body number N° 0032 in accordance with Article 9 of the Council Directive 94/9/EC of March 23, 1994, certifies that this equipment or protective system has been found to comply with the Essential Health and Safety Requirements relating to the design and construction of equipment and protective systems intended for use in potentially explosive atmospheres given in Annex II to the Directive.
- The examination and test results are recorded in confidential report N° 02YEX 164852.
- (9) Compliance with the Essential Health and Safety Requirements has been assured by compliance with:
- EN 50021:1999**
- (10) If the sign "X" is placed after the certification number, it indicates that the equipment or protective system is subject to special conditions for safe use specified in the schedule to this certificate.
- (11) This statement of conformity certificate relates only to the design, examination and tests of the specified equipment in accordance to the Directive 94/9/EC. Further requirements of the Directive apply to the manufacturing process and supply of this equipment or protective system. These are not covered by this certificate.
- (12) The marking of the equipment or protective system shall include the following:



II 3 G EEx EEx n A II T6

TÜV NORD CERT GmbH & Co. KG
TÜV CERT-Certification Body
Am TÜV 1
D-30519 Hannover
Tel.: 0511 997-1470
Fax: 0511 996-2555

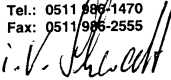
Head of the
Certification Body

Hanover, 2002-07-17



TÜV NORD CERT

TUV CERT A4 0701 10.000 L0

This statement of conformity may only be reproduced without any change, schedule included.
Excerpts or changes shall be allowed by the TÜV NORD CERT GmbH & Co. KG

page 1/3



SCHEDULE

(13)

(14) STATEMENT OF CONFORMITY N° TÜV 02 ATEX 1867 X

(15) Description of equipment or protective system

The Positioner TZID type Doc 900920 is used for the conversion of an impressed d. c. current (0 ... 20 mA) into a proportional pressure, which can be used for the control of pneumatically adjustable devices.

The Positioner TZID type Doc 900920 may be installed in explosion hazardous areas that require apparatus of the category 3.

The permissible ambient temperature range in dependence of the temperature class has to be taken from the following table:

Temperature class	Ambient temperature range
T6	-40°C to +50°C
T5	-40°C to +65°C
T4	-40°C to +85°C

Electrical data

Analog input circuit U = 9,8 V d. c.; 4 ... 20 mA, max. 21,5 mA
(Terminals 12[-], 11[+])

Alarm circuit (min.) U = 25 V d. c., 12 mA
(Terminals 42[-], 41[+])

Alarm circuit (max.) U = 25 V d. c., 12 mA
(Terminals 52[-], 51[+])

Analog output circuit U = 30 V d. c.; 4 ... 20 mA, max. 21,5 mA
(Terminals 32[-], 31[+])

circuit for
digital feedback U = 16 V d. c.; 7 mA
(Terminals 44[-], 45[+])

(16) Test documents are listed in the test report no. 02YEX164852.

(17) Special conditions for safe use

1. Only devices, which are suitable for the operation in explosion hazardous areas of the zone 2 and the conditions available at the place of operation (Declaration of conformity or certificate of a testing department), are allowed to be connected to non intrinsically safe circuits in the zone 2.
2. The connecting and disconnecting as well as the switching of circuits under voltage, is only permitted during installation, for maintenance or for repair purposes.
Note: The temporal coincidence of explosion hazardous atmosphere and installation, maintenance resp. repair purposes is assessed as unlikely.
3. For the alarm circuits, the circuit for the digital feedback and the analog output circuit measures have to be taken outside the device, that the rated voltage is exceeded not more than 40% by transient disturbances.
4. Only non combustible gases are allowed to be used as pneumatic auxiliary energy.
5. Only suitable cable entries, which meet the requirements of EN 50 021, are allowed to be used.

(18) Essential Health and Safety Requirements

no additional ones



EC-TYPE-EXAMINATION CERTIFICATE

(Translation)

- (2) Equipment and Protective Systems Intended for Use in Potentially Explosive Atmospheres - **Directive 94/9/EC**
- (3) EC-type-examination Certificate Number:



PTB 00 ATEX 2049 X

- (4) Equipment: SN-sensors, types NJ... and SJ...
- (5) Manufacturer: Pepperl + Fuchs GmbH
- (6) Address: D-68307 Mannheim
- (7) This equipment and any acceptable variation thereto are specified in the schedule to this certificate and the documents therein referred to.
- (8) The Physikalisch-Technische Bundesanstalt, notified body No. 0102 in accordance with Article 9 of the Council Directive 94/9/EC of 23 March 1994, certifies that this equipment has been found to comply with the Essential Health and Safety Requirements relating to the design and construction of equipment and protective systems intended for use in potentially explosive atmospheres, given in Annex II to the Directive.
- The examination and test results are recorded in the confidential report PTB Ex 00-29268.
- (9) Compliance with the Essential Health and Safety Requirements has been assured by compliance with:
EN 50014:1997 **EN 50020:1994**
- (10) If the sign "X" is placed after the certificate number, it indicates that the equipment is subject to special conditions for safe use specified in the schedule to this certificate.
- (11) This EC-type-examination Certificate relates only to the design and construction of the specified equipment in accordance with Directive 94/9/EC. Further requirements of this Directive apply to the manufacture and supply of this equipment.
- (12) The marking of the equipment shall include the following:

II 2 G EEx ia IIC T6

Zertifizierungsstelle Explosionsschutz
By order:

Braunschweig, October 05, 2000

Dr.-Ing. U. Johannsmeyer
Regierungsdirektor



sheet 1/4

EC-type-examination Certificates without signature and official stamp shall not be valid. The certificates may be circulated only without alteration. Extracts or alterations are subject to approval by the Physikalisch-Technische Bundesanstalt. In case of dispute, the German text shall prevail.

Physikalisch-Technische Bundesanstalt • Bundesallee 100 • D-38116 Braunschweig

SCHEDULE

(13)

(14) **EC-TYPE-EXAMINATION CERTIFICATE PTB 00 ATEX 2049 X**

(15) Description of equipment

The SN-sensors, types NJ... and SJ... are used to convert displacements into electrical signals.

The SN-sensors, types NJ... and SJ... may be operated with intrinsically safe circuits certified for categories and explosion groups [EEx ia] IIC or IIB resp. [EEx ib] IIC or IIB. The category as well as the explosion group of the SN-sensors depends on the connected supplying intrinsically safe circuit.

Electrical data

Evaluation and

supply circuit..... type of protection Intrinsic Safety EEx ia IIC/IIB
 resp. EEx ib IIC/IIB

only for connection to certified intrinsically safe circuits
 maximum values:

type 1	type 2	type 3	type 4
$U_i = 16 \text{ V}$	$U_i = 16 \text{ V}$	$U_i = 16 \text{ V}$	$U_i = 16 \text{ V}$
$I_i = 25 \text{ mA}$	$I_i = 25 \text{ mA}$	$I_i = 52 \text{ mA}$	$I_i = 76 \text{ mA}$
$P_i = 34 \text{ mW}$	$P_i = 64 \text{ mW}$	$P_i = 169 \text{ mW}$	$P_i = 242 \text{ mW}$

The assignment of the type of the connected circuit to the maximum permissible ambient temperature and the temperature class as well as the effective internal reactances for the individual types of SN-sensors is shown in the following table:

types	C _i [nF]	L _i [µH]	type 1			type 2			type 3			type 4		
			maximum permissible ambient temperature in °C for application in temperature class											
			T6	T5	T4-T1	T6	T5	T4-T1	T6	T5	T4-T1	T6	T5	T4-T1
NJ 2-11-SN...	50	150	73	88	100	66	81	100	45	60	89	30	45	74
NJ 2-11-SN-G...	50	150	76	91	100	73	88	100	62	77	81	54	63	63
NJ 2-12GK-SN...	50	150	73	88	100	69	84	100	51	66	80	39	54	61
NJ 3-18GK-S1N...	70	200	73	88	100	69	84	100	51	66	80	39	54	61
NJ 4-12GK-SN...	70	150	73	88	100	69	84	100	51	66	80	39	54	61
NJ 5-18GK-SN...	120	200	73	88	100	69	84	100	51	66	80	39	54	61
NJ 5-30GK-S1N...	100	200	73	88	100	69	84	100	51	66	80	39	54	61
NJ 6-22-SN...	110	150	73	88	100	69	84	100	51	66	80	39	54	61
NJ 6-22-SN-G...	110	150	76	91	100	73	88	100	62	77	81	54	63	63
NJ 6S1+U.+N...	180	150	73	88	100	69	84	100	51	66	80	39	54	61
NJ 8-18GK-SN...	120	200	73	88	100	69	84	100	51	66	80	39	54	61
NJ 10-30GK-SN...	120	150	73	88	100	69	84	100	51	66	80	39	54	61
NJ 15-30GK-SN...	120	180	73	88	100	69	84	100	51	66	80	39	54	61
NJ 15S-U.-N...	180	150	73	88	100	66	81	100	45	60	89	30	45	74
NJ 20S-U.-N...	200	150	73	88	100	66	81	100	45	60	89	30	45	74
NJ 40-FP-SN...	370	300	73	88	100	66	81	100	45	60	89	30	45	74
SJ 2-SN...	30	100	73	88	100	66	81	100	45	60	78	30	45	57
SJ 2-S1N...	30	100	73	88	100	66	81	100	45	60	78	30	45	57
SJ 3,5-S1N...	30	100	73	88	100	66	81	100	45	60	89	30	45	74
SJ 3,5-SN...	30	100	73	88	100	66	81	100	45	60	89	30	45	74

(16) Test report PTB Ex 00-29268

(17) Special conditions for safe use

1. For the application within a temperature range of -60 °C to -20 °C the SN-sensors, types NJ... and SJ... must be protected against damage due to impact by mounting into an additional housing.
2. The connection facilities of the SN-sensors, types NJ... and SJ... shall be installed as such that at least a degree of protection of IP20 according to IEC-publication 60529:1989 is met.
3. The assignment of the type of the connected circuit to the maximum permissible ambient temperature and the temperature class as well as the effective internal reactances for the individual types of SN-sensors is shown in the table given under item (15) of this EC-type-examination certificate.

sheet 3/4

EC-type-examination Certificates without signature and official stamp shall not be valid. The certificates may be circulated only without alteration. Extracts or alterations are subject to approval by the Physikalisch-Technische Bundesanstalt. In case of dispute, the German text shall prevail.

Physikalisch-Technische Bundesanstalt • Bundesallee 100 • D-38116 Braunschweig

4. With the application in group IIC inadmissible electrostatic charge of the plastic housing has to be avoided for following types of SN-sensors (warning label on the device):

NJ 40-FP-SN...

5. Inadmissible electrostatic charge of parts of the metal housing has to be avoided for the following types of SN-sensors. Dangerous electrostatic charges of parts of the metal housing can be avoided by grounding of these parts whereas very small parts of the metal housing (e.g. screws) don't need to be grounded:

NJ 2-11-SN-G...

NJ 6-22-SN-G...

NJ 6S1+U3+N...

NJ 6S1+U4+N...

NJ 15S+U3+N...

NJ 15S+U4+N...

NJ 20S+U3+N...

NJ 20S+U4+N...

NJ 40-FP-SN-P3...

NJ 40-FP-SN-P4...

(18) Essential health and safety requirements

Met by the standards mentioned above

Zertifizierungsstelle Explosionsschutz

By order:

Dr.-Ing. U. Johannsmeyer
Regierungsdirektor



Braunschweig, October 05, 2000

sheet 4/4

EC-type-examination Certificates without signature and official stamp shall not be valid. The certificates may be circulated only without alteration. Extracts or alterations are subject to approval by the Physikalisch-Technische Bundesanstalt. In case of dispute, the German text shall prevail.

Physikalisch-Technische Bundesanstalt • Bundesallee 100 • D-38116 Braunschweig

**APPROVED PRODUCT/SPECIFICATION TESTED - REVISION REPORT
OR ADDRESS/CONTACT CHANGE REPORT**

Page 1 of 2



SENDER: Forward with updated drawings or other appropriate change information to the attention of the Approvals Division. Original will be returned showing course of action taken.

Additional forms may be requested by writing to the attention of the **Factory Mutual Research Stock Room.**

FORWARD TO:
Factory Mutual Research
1151 Boston-Providence Turnpike
P.O. Box 9102 Norwood, MA 02062
T: 781 762 4300 F: 781 762 9375
http://www.fmglobal.com

Please type below: Attention of, Company Name, Address, City, State & Zip Code.

Attn: Heinfried Neuhaus, R&D Engineer
ABB Automation Products GmbH
Schillerstrasse 72
D-32425 Minden
Germany

ATTENTION:
DATE: **August 16, 2000**
FORWARD BY: **Heinfried Neuhaus**
TITLE: **R&D Engineer**
SIGNATURE:

Phone: +49-571-830-1963 Fax: +571-830-1880

PRODUCT(S)
1/P Signal Converters Typ 22/06, 22/08 and Positrons TZIM Ex, TZID-Ex and TZID-EXP

MODEL(S) AFFECTED:
Models: 22/06, 22/08, TZIM Ex, TZID-Ex and TZID-EXP

DOES THIS REVISION RESULT IN MODEL/TYPE NO CHANGE TO THE CURRENT APPROVAL GUIDE LISTING? IF YES, EXPLAIN (USE SEPARATE SHEET IF REQUIRED) YES NO

INDICATE FACTORY MUTUAL RESEARCH JOB IDENTIFICATION(S) AFFECTED:
J.1. 1P3A4.AE, 5Y3A6.AX, 1P8A7.AX, 0D5Q7.AE, OR3H2.AE, 2Z5A2.AE, 2B0A4.AE, OR8A3.AE, 1B6A9.AX

HAS THE MANUFACTURING LOCATION, LISTING ADDRESS, TELEPHONE NUMBER OR CONTACT PERSON CHANGED? IF YES, EXPLAIN BELOW. YES NO

REVISION DETAILS	DWG. NO. AFFECTED	REV.	NEW DWG. NO.	REV.
Name change from: Hartmann & Braun GmbH & Co KG	900832	0	900832	1
to: ABB Automation Products GmbH	900833	0	900833	1
Production has moved early 2000	900834	1	900834	2
from: Hackethalstrasse 7, D-30179 Hannover, Germany	900841	2	900841	3
to: Schillerstrasse 72, D-32425 Minden, Germany	900842	0	900842	1
Phone: +49-571-830-0	900843	0	900843	1
Production facility Hannover will be closed	900844	0	900844	1
	900090	1	900090	2
Revision of label artwork and control documents to include ABB logo	900988	1	900988	2
	900980	1	900980	2
			901126	0
Contact Person will be further:	274927	C	274927	1
Dr. Thomas Karte, R&D Manager	900924	5	900924	6
Heinfried Neuhaus, R&D Engineer	900925	7	900925	8
Dernd Swider, QA Manager	293016	4	293016	5

REASON FOR CHANGE(S)/COMMENTS:
Hartmann & Braun GmbH & Co. KG/Sensycon GmbH is now part of the ABB company.

BELOW FOR FACTORY MUTUAL RESEARCH USE

COMMENTS: ABB Automation Products GmbH is already listed in the Approval Guide, however, only under Alzenau, Germany site. With this Revision Report the products presently listed in the Approval Guide under Sensycon GmbH will now be listed under their new name ABB Automation Products GmbH under their Minden, Germany site separately (and not added to the Alzenau, Germany site.) Revisions to the Label and Control Drawings do not affect safety. See new Approval Guide Listing on back. CDL's Updated	REVISION REPORT J.1. 3008208	REVISION NOTICE NO. -----	CLASS NO. 3610
	FORWARD APPROVAL/SPECIFICATION TESTED AGREEMENT <input checked="" type="checkbox"/> Yes <input type="checkbox"/> No		
	REVISION ACCEPTED <input checked="" type="checkbox"/> Yes <input type="checkbox"/> No		
	EXAMINED BY: 	DATE: 10-12-00	
REVIEWED BY: 	DATE: 10/12/00		

797/rev1 (11/99) Factory Mutual Research PRINTED IN US

Below is a copy of how the ABB Automation Products GmbH, Minden, Germany products will be listed in the Approval Guide:

ABB Automation Products GmbH Schillerstrasse 72, D-32425 Minden, Germany

Model 22/06-6a. I/P Signal Converter.

IS / I / 1 / ABCD — 900842 / 1, 900843 / 1, 900844 / 1; Entity;
NI / I / 2 / ABCD

Entity Parameters:
V_{max} = 40 V, I_{max} = 125 mA, C_i = 0 F, L_i = 1.0 mH.

a = 1, 2, 3, 4 or 5.

Model 22/06-6a. I/P Signal Converter.

IS / I,II,III / 1 / ABCDEFG — 900842 / 1, 900843 / 1, 900844 / 1; Entity;
NI / I / 2 / ABCD;
S / II / 2 / G; S / III / 2

Entity Parameters:
V_{max} = 40 V, I_{max} = 125 mA, C_i = 0 F, L_i = 1.0 mH.

a = 6, 7, 8 or 9.

Models 22/06-a. I/P Signal Converter.

XP / I / 1 / BCD;
DIP / II,III / 1 / EFG

a = 66, 67, 68, 69, 99 or 99-1.

Models 22/08-18, 21/13-18 and 21/13-28. P/I Signal Converter.

XP / I / 1 / ABCD;
DIP / II,III / EFG

Model TZID-EXP. Intelligent Positioner.

XP / I / 1 / BCD; DIP / II,III / 1 / EFG

Model TZID Ex. Smart Positioner.

IS / I,II,III / 1 / ABCDEFG — 900925 / 8; Entity;
NI / I / 2 / ABCD;
S / II / 2 / FG; S / III / 2

Entity Parameters:
V_{oc} = 40 V, I_{sc} = 203 mA, C_a = 2.4 nF, L_a = 50 H.

Model TZIM Ex. Positioner.

IS / I / 1 / ABCD — 900988 / 2; Entity;
NI / I / 2 / ABCD

Entity Parameters:
V_{max} = 40 V, I_{max} = 125 mA, C_i = 0, L_i = 1 mH.



CERTIFICATION RECORD

The company named below has been authorized by CSA to represent the products listed in this record as "CSA Certified" and to affix the CSA Mark to these products according to the terms and conditions of the CSA Service Agreement and applicable CSA program requirements (including additional Markings).

File No: 110417 0 000

Class No: 2258 02 PROCESS CONTROL EQUIPMENT For Hazardous Locations

SUBMITTOR

262501 Hartmann & Braun GmbH & Co. KG
Hackethalstrasse 7
Hannover, D-30179
GERMANY

FACTORIES

233712 Elsag Bailey (Canada) Inc.
134 Norfinch Drive
Downsview, ON M3N 1X7
Canada

262501 Hartmann & Braun GmbH & Co. KG
Hackethalstrasse 7
Hannover, D-30179
GERMANY

279891 Bailey-Fischer & Porter Company
125 East County Line Rd.
Warminster, PA 18974
USA

December 10, 1998(Replaces:July 29, 1998)

Class I, Div. 2, Groups A, B, C and D; Class II, Div. 2, Groups E, F and G; Class III; Encl Type 4X:

- Model TZID, P/N 18341xxxxxxx Smart Positioner; input rated 40V dc max, 4-20mA; max ambient 85 deg C.
 - Model AZHx1x0xx smart Positioner; input rated 40V dc max, 4-20mA; max ambient 85 deg C.
- bds

DQD No. 548-Rev B

Page 1



CERTIFICATION RECORD

The company named below has been authorized by CSA to represent the products listed in this record as "CSA Certified" and to affix the CSA Mark to these products according to the terms and conditions of the CSA Service Agreement and applicable CSA program requirements (including additional Markings).

File No: 110417 0 000
Class No: 2258 04 PROCESS CONTROL EQUIPMENT Intrinsically Safe, Entity - For Hazardous Locations

SUBMITTOR

262501 Hartmann & Braun GmbH & Co. KG
Hackethalstrasse 7
Hannover, D-30179
GERMANY

FACTORIES

233712 Elsag Bailey (Canada) Inc.
134 Norfinch Drive
Downsview, ON M3N 1X7
Canada

262501 Hartmann & Braun GmbH & Co. KG
Hackethalstrasse 7
Hannover, D-30179
GERMANY

279891 Bailey-Fischer & Porter Company
125 East County Line Rd.
Warminster, PA 18974
USA

December 10, 1998(Replaces:July 29, 1998)

Class I, Div. 1, Groups A, B, C and D; Class II, Div. 1, Groups E, F and G; Class III, Div. 1; Encl. Type 4X:

- Model TZID, P/N 18341-xxxxx00, 18341-xxxxx20, 18341-xxxxx60 and 18341-xxxxx90 Smart Positioner; input rated 40 Vdcmax, 4-20 mA; intrinsically safe with entity parameters of: Vmax = 40V, Imax = 203mA, Terminals 11/12: Ci = 2.4 nF, Li = 50 uH; Terminals 31/32: Ci =2.4 nF, Li = 50 uH; Terminals 41/42: Ci =2.4 nF, Li =50 uH;Terminals 44/45: Ci =2.4 nF, Li = 50 uH; Terminals 51/52: Ci =2.4 nF, Li =50 uH; when installed per installation Dwg. 900925; Temp. Code T4; Max Ambient 85 Deg C.
- Model TZID, P/N 18341-xxxxx22, 18341-xxxxx24, 18341-xxxxx82 and 18341-xxxxx84 Smart Positioner; input rated 40 Vdcmax, 4-20 mA; intrinsically safe with entity parameters of: Vmax = 40V, Imax = 203mA, Terminals 11/12: Ci = 2.4 nF, Li = 50 uH; Terminals 31/32: Ci =2.4 nF, Li = 50 uH; Terminals 41/42: Ci =61.2 nF, Li =144 uH;Terminals 44/45: Ci =2.4 nF, Li = 50 uH; Terminals 51/52: Ci =61.2 nF, Li =144 uH; when installed per installation Dwg. 900925; Temp. Code T4; Max Ambient 85 Deg C.
- Model AZHx1x0x0 Smart Positioner; input rated 40 Vdcmax, 4-20 mA; intrinsically safe with entity parameters of: Vmax = 40V, Imax = 203mA, Terminals 11/12: Ci = 2.4 nF, Li = 50 uH; Terminals 31/32: Ci =2.4 nF, Li = 50 uH; Terminals 41/42: Ci =2.4 nF, Li =50 uH;Terminals 44/45: Ci =2.4 nF, Li = 50 uH; Terminals 51/52: Ci =2.4 nF, Li =50 uH; when installed per installation Dwg. B1113584; Temp. Code T4; Max Ambient 85 Deg C.
- Model AZHx1x0x1 Smart Positioner; input rated 40 Vdcmax, 4-20 mA; intrinsically safe with entity parameters of: Vmax = 40V, Imax = 203mA, Terminals 11/12: Ci = 2.4 nF, Li = 50 uH; Terminals 31/32: Ci =2.4 nF, Li = 50 uH; Terminals 41/42: Ci =61.2 nF, Li =144 uH;Terminals 44/45: Ci =2.4 nF, Li = 50 uH; Terminals 51/52: Ci =61.2 nF, Li =144 uH; when installed per

DQD No. 548-Rev B

Page 1



Certification Record No: 110417 0 000

Class No: 2258 04

installation Dwg. B1113584; Temp. Code T4; Max Ambient 85 Deg C.

Note: The "x" in the Part Number denotes minor mechanical and electrical variations, not affecting intrinsic or electrical safety.

bds

DQD No. 548-Rev B

Page 2



PROFILE OF CERTIFICATION REPORTS

File No: 110417 0 000

Submittor:
Hartmann & Braun GmbH & Co. KG
Hackethalstrasse 7
D-30179 Hanover, Germany
Attention: Mr. Thomas Karte

Date: December 10, 1998
Replaces: July 29, 1998

Factories:	Inspection Office:	File No:
Contact ID	Name & Address	
262501	F1 Hartmann & Braun GmbH & Co. KG Hackethalstrasse 7 D-30179 Hanover, Germany	VDE 110417
233712	F2 Eltag Bailey (Canada) Inc. 134 Norfinch Drive Downsview, ON M3N 1X7	Etobicoke 110417
279891	F3 Bailey-Fisher & Porter Co. 125 East County Line Rd. Warminster, PA 18974	Etobicoke 110417

Rep No	App. No	Contact ID	Subject
-1	-	-	July 29, 1998 - Models TZID and AZH positioner, intrinsically safe for hazardous locations
2	-	-	December 10, 1998 - Addition of Two New Factory Location: F2 Eltag Bailey (Canada) Inc. 134 Norfinch Drive Downsview, ON M3N 1X7 F3 Bailey-Fisher & Porter Co. 125 East County Line Rd. Warminster, PA 18974

/jmb



Descriptive and Test Report

Montréal ■ Toronto ■ Edmonton ■ Vancouver ■ Tokyo ■ Hong Kong

REPORT NO: LR 110417-2

Edition 1: December 10, 1998; Application No LR 110417-2 - Etobicoke
Issued by John Ferguson

Contents: Pages - 1 of 2

CLASS

CLASS 2258 02 - PROCESS CONTROL EQUIPMENT - For Hazardous Locations

CLASS 2258 04 - PROCESS CONTROL EQUIPMENT - Intrinsically Safe Entity - For Hazardous Locations

SUBJECT

This report covers the addition of two new factory locations as follows:

F2 (Contact 233712)

Elsag Bailey (Canada) Inc.
134 Norfinch Drive
Downsview, ON M3N 1X7
Canada

F3 (Contact 279891)

Bailey-Fischer & Porter Company
125 East County Line Rd.
Warminster, PA 18974
USA

Canadian Standards Association, 178 Rexdale Boulevard, Etobicoke, Ontario, Canada M9W 1R3

Telephone: (416) 747-4000 Telefax: (416) 747-4149

10417.2\1\sm

APPLICABLE REQUIREMENTS

As previously recorded.

MARKINGS

As previously recorded.

ALTERATIONS

As previously recorded.

FACTORY TESTS

As previously recorded.

DESCRIPTION

As previously recorded.

TESTS

As previously recorded.

Appendix A: Error codes

Error code	Reason	Effect	Required user action
E01	Fatal error in boot phase	Control disturbed	Load the factory setting *).
E02	No valid configuration data available in EEPROM	Control disturbed	Load the factory setting *).
E03 - 11 E15 - 17 E26 - 7 E90 - 91	Internal data error	Output depressurized or blocked, depending on model	Press the Reset button. If this does not solve the problem, load the factory setting *).
E13 - 14	High or low alarm limit of digital feedback is out of range	None	Correct the alarm limit setting.
E18	Stop of angle of rotation reached.	Control stopped, current position blocked	Check the mechanical linkage for position sensing. If required, reset it to the adjusted range.
E19	Positioning time-out	None	Check the actuator/valve. Check the air tubing.
E20	Autostroke disabled	None	Enable Autostroke (only possible via a PC with the appropriate TZID software).
E21	Autostroke time-out (time limit for one step is approximately 100 seconds)	Autostroke aborted	Check the actuator/valve. Check the air tubing.
E22	Angular range exceeded during Autostroke	Autostroke aborted	Check the mechanical linkage for position sensing. If required, reset it to the adjusted range.

Error code	Reason	Effect	Required user action
E23	Used angular range too small	Autostroke aborted	Check the mechanical linkage for position sensing. Set it to at least 20 % of the range.
E24	Wrong direction of action (only for "zero" Autostroke)	Autostroke aborted	Correct the direction of action of the actuator (only possible via a PC with the appropriate TZID software).
E27	Autostroke cancelled manually	Autostroke aborted	Press the Reset button to acknowledge.
E30/31	Dead band too small (30) or too big (31)	None	Set the dead band to the permissible range.
E32/33	Manual zero adjustment in operating mode 2.3 out of range	None	Set the zero adjustment to the permissible range.
E34	Automatic control not active (operating mode 1.2-1.3-2.1-2.2-2.3 or 2.0 during Autostroke)	None	Activate automatic control in operating mode 1.0 or 1.1 if you want to terminate the inactive state.
E37	Signal out of range 4...20 mA	None	Set the signal to the range 4...20 mA.
E40	Setting of parameters disabled	None	Enable parameter setting (only possible via a PC with the appropriate TZID software).
E41	Output 0 % and 100 % not entered manually (only for "zero" Autostroke)	Autostroke aborted	Enter output 0 % and 100 % (only possible via a PC with the appropriate TZID software).
E42	Leakage in actuator	None	Check the actuator or tubes for leakage.

Error code	Reason	Effect	Required user action
E43	Limits of stroke counter or travel meter for diagnosis exceeded	None	Diagnose according to the diagnostic plan.
E77/80	Total EEPROM data loss	Output depressurized or blocked, depending on setting for the model	Load the factory setting *) or tag-specific settings.
E78/81/82	EEPROM defective, data can only be read	Saving data in the non-volatile memory is no longer possible.	Replace the device.
E79	EEPROM defective	Output depressurized or blocked, depending on setting for the model	Replace the device.
E92	Short-time interruption of input signal > 20 ms	Output depressurized or blocked, depending on setting for the model	Check the input signal.
E93	Watchdog, internal self-monitoring	Output depressurized or blocked, depending on setting for the model	Press the Reset button, check the environment for electromagnetic interference.

The Industrial^{IT} wordmark is a registered or pending trademark of ABB.

ABB has Sales & Customer Support expertise in over 100 countries worldwide.

www.abb.com

The Company's policy is one of continuous product improvement and the right is reserved to modify the information contained herein without notice.

Printed in the Fed. Rep. of Germany (07.2007)

© ABB 2007



ABB Ltd.

Salterbeck Trading Estate
Workington, Cumbria
CA14 5DS
UK
Tel: +44 (0)1946 830 611
Fax: +44 (0)1946 832 661

ABB Inc.

125 E. County Line Road
Warminster, PA 18974
USA
Tel: +1 215 674 6000
Fax +1 215 674 7183

ABB Automation Products GmbH

Schillerstr. 72
32425 Minden
Germany
Tel: +49 551 905-534
Fax: +49 551 905-555
CCC-support.deapr@de.abb.com