

TEIP 11

I/P signal converter
without power stage

Operating manual

42/18-61 EN

Rev. 02

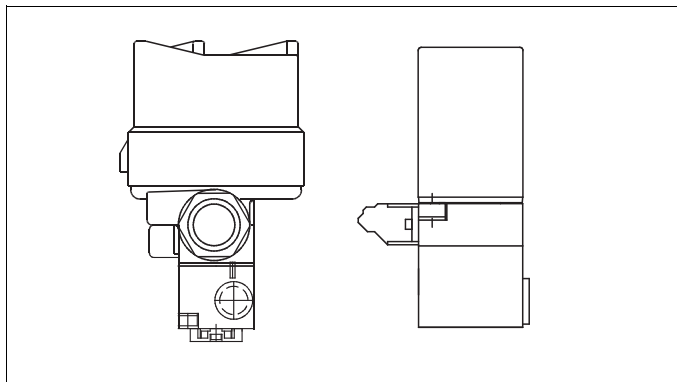

I/P signal converter TEIP 11

without power stage

Operating manual

Document No. 42/18-61 EN

Release date 09.02

Version 02

Manufacturer:

ABB Automation Products GmbH
Schillerstrasse 72
32425 Minden

Tel: +49 571 830-1494

Fax: +49 571 830-1860

© Copyright 2002 by ABB Automation Products GmbH

Subject to changes without notice.

This technical documentation is protected by copyright. Translating, photocopying and disseminating it in any form whatsoever - even editings or excerpts thereof - especially as reprint, photomechanical or electronic reproduction or storage on data processing systems or networks is not allowed without the permission of the copyright owner and non-compliance will lead to both civil and criminal prosecution.

Table of contents

1	Safety and precautions	1
1.1	General safety instructions.....	1
1.2	Requirements/conditions for safe use of explosion-proof TEIP 11 signal converters (type Doc. 900771)	2
2	General	5
2.1	Application and brief description.....	5
2.2	Deliverables.....	7
2.3	Scope of delivery	7
2.4	CE compliance information	7
3	Mounting	8
3.1	Operating conditions at the installation site.....	8
3.2	Mounting the model with control room housing	9
3.3	Mounting the model with aluminum or stainless steel field housing unit.....	9
4	Connecting	10
4.1	Electrical connection.....	10
4.2	Pneumatic connection.....	12
5	Commissioning	12

6	Maintenance	13
6.1	Checking / replacing the air filter	13
6.2	Readjusting the signal converter	14
7	Technical data	15
8	Dimensional drawings, connection diagrams	21

1 Safety and precautions



Warning

**Important instructions for your safety!
Read and observe!**

1.1 General safety instructions

Correct and safe operation of the TEIP 11 or TEIP 11 Ex signal converter calls for appropriate transportation and storage, expert installation and commissioning, correct operation and careful maintenance.

Only those persons familiar with the installation, commissioning, operation and maintenance of this signal converter or similar instruments and who have the required qualification are allowed to work on the device.

Observe:

- these operating instructions,
- the safety regulations and standards pertaining to the installation and operation of electrical systems,
- the standards, regulations and directives governing explosion protection, if explosion-proof devices are used.

The regulations, standards and directives referred to in these operating instructions are applicable in Germany. When using the signal converter in other countries, the national regulations, standards and directives applicable in the respective country must be observed.

The signal converter has been manufactured and tested in accordance with DIN VDE 0411 Part 1

“Safety Requirements for Electronic Measuring Apparatuses”
and has been supplied in a safe condition.

Prior to delivery, all devices have been tested for proper and safe operation. These operating instructions contain warnings and cautions marked with \triangle . The instructions given in these sections must be observed to retain the device in a safe condition and to ensure safe operation. Otherwise, persons can be endangered or the device itself or other equipment may be damaged or fail.

If you should need information that is not contained in the present operating instructions please do not hesitate to contact us.

1.2 Requirements/conditions for safe use of explosion-proof TEIP 11 signal converters (type Doc. 900771)



Prior to installing check to ensure that the specifications in terms of safety and control applicable to the TEIP 11 signal converter will not be exceeded.

When making the electrical connections observe the specifications in section "Technical data" and the specifications in the explosion protection certificate.

The device must be supplied with instrument air that is free of oil, water and dust. Do not use flammable gas nor oxygen or oxygen-enriched gas.

Do not open the device immediately after switch-off. Wait for at least 4 minutes.

Handle the cover with care. Otherwise, the thread may be damaged. This will void the explosion protection (Ex d).



Warning

Exclusively use cable glands with full Ex-d approval for EEx-d operation.

Secure the cable and tube entries against turning and loosening by using security adhesive of medium strength.

If the signal converter is used at an ambient temperature above 60 °C (140°F) or below -20 °C (-4 °F), use cable entries and cables approved for a service temperature corresponding to the maximum ambient temperature increased by 10 K or corresponding to the minimum ambient temperature, respectively.

Devices which – in the new state – comply with type of protection “Ex-ia” and “Ex-d” should not be used intrinsically safe “Ex-ia” once they have been commissioned and used in an environment with type of protection “Ex-d”, since the electronics may have been damaged.

Specifications:

Input signal

(0) 4...20 mA

Supply pressure, depending on type:

1.4 - 10 bar

1.4 - 4 bar

other ranges depending on type

Thermal specifications for explosion protection type Ex d:

The following limit values for the temperature classes must be observed for the intrinsically safe versions of the control unit:

Temperature class	Input current [mA]	Ambient temperature [°C]
T6	50 mA	-40° C...+60° C
T6	60 mA	-40° C...+55° C
T5	60 mA	-40° C...+70° C
T4	60 mA	-40° C...+85° C
T5	100 mA	-40° C...+55° C
T4	100 mA	-40° C...+85° C
T5	120 mA	-40° C...+45° C
T4	120 mA	-40° C...+80° C
T4	150 mA	-40° C...+70° C

The following limit values for the temperature classes must be observed for the non-intrinsically safe versions of the control unit:

Temperature class	Input current [mA]	Ambient temperature [°C]
T6	50 mA	-40° C...+55° C
T5	50 mA	-40° C...+70° C
T4	50 mA	-40° C...+85° C

2 General

2.1 Application and brief description

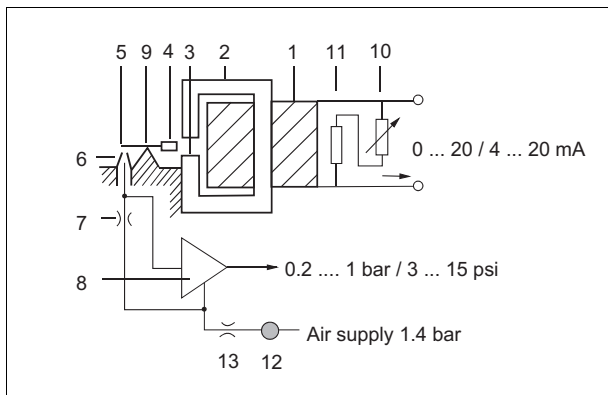

Fig. 1 Functional diagram

The TEIP 11 or TEIP 11 Ex Signal Converter converts electrical into pneumatic standard signals, e.g. 4...20 mA into 0.2...1 bar. It is, thus, a connecting link **between the electrical/electronic** and the pneumatic systems. The patented signal conversion principle is based on the force balance method. Force balancing takes place at the lever arm which is pivoted with a tension band at (9).

The coil (1) and yoke (2) generate a magnetic field in the air gap (3) which applies a force to the magnet (4) on the lever arm. The force changes in proportion to the current (input signal) flowing through the coil (1).

On the other side of the lever arm a counterforce is applied through the dynamic air pressure present at the air nozzle (6)

and the flapper (5). The force is controlled in such a way that a balance of the two torques is achieved. If a torque imbalance occurs, the lever arm is rotated. This rotation changes the air gap between the nozzle (6) and the flapper (5) and, thus, the dynamic air pressure.

Air is permanently supplied to the nozzle (6) through the throttle (7). The 1:1 converter stage (8) converts the dynamic air pressure into a 0.2...1 bar or 3...15 psi output signal. The air is fed in through the air filter (12) and fixed throttle (13).

Zero adjustment can be done on the tension band suspension (9), and range adjustment on the potentiometer (10).

Special features of the TEIP 11 and TEIP 11 Ex signal converter are its relatively small dimensions and high operational stability when submitted to shock and vibration. The stability is due to the light weight (only 100 mg) of the moving system, which consists of the lever arm with the magnet (4) and the flapper (5).

The air filter (12) prevents malfunctions caused by polluted air. Note that the filter capacity is only sufficient for collecting dirt that occurs occasionally (e.g. residual dirt in the air pipes at first use). It is no substitute for proper air conditioning. Some models are not equipped with an air filter (See "Maintenance" on page 13.)

The pneumatic module was designed without an air power stage, for the benefit of small dimensions and low cost. Due to the reduced air capacity the signal converter can be used for controlling small volume systems, only.

2.2 Deliverables

For details on the deliverable signal converter models and their accessories please refer to data sheet 10/18-0.11 EN, which also includes the catalog numbers of the individual items.

2.3 Scope of delivery

Check the delivery (items and scope of delivery) immediately upon arrival to see if it is in accordance with your order.

The following loose accessories are delivered with the unit as extra items:

- Mounting bracket for the aluminum or stainless steel field housing unit (for wall or 2" pipe mounting)
- Cable entry for signal converter with "EEx d" explosion protection

2.4 CE compliance information

We herewith declare that we are the manufacturer of the TEIP 11 signal converter and that the device meets the requirements of the EC directive 89/336/EEC as of May 1989 due to compliance with the following standards:

RFI suppression

EN 55011 as of 1991

EMI/RFI shielding

EN 50082-1 as of January 1991

EN 50082-2 (PR) as of November 1993

The TEIP 11 signal converter meets the requirements of the EC directive for CE conformity marking.

3 Mounting

3.1 Operating conditions at the installation site



Prior to mounting check to ensure that the specifications in terms of safety and control applicable to the TEIP 11 signal converter will not be exceeded.

Ambient temperature:

40...+85 °C or -55...+85 °C, depending on the ordered model (see also additional information under "Technical Data")

Protection:

IP 20 with control room housing unit

IP 65 with aluminum/stainless steel field housings

Explosion protection:

ATEX EEx ia or EEx d

CENELEC EEx ia or EEx d

BRITISH Standards Ex N

FM/CSA intrinsically safe

FM/CSA explosion proof

(see also additional information under "Technical data")

Mounting orientation:

any orientation allowed

3.2 Mounting the model with control room housing

This model is snap-mounted on a DIN top-hat rail.

The signal converter has a special mounting base. Due to its universal design it is suitable for mounting to EN 50022 - 35x7.5, EN 50045 - 15x5 and EN 50035 - G32 rails. Preferably position the signal converter with the electrical connection towards the left hand side when mounting to a vertical rail, and upwards when mounting to a horizontal rail.

3.3 Mounting the model with aluminum or stainless steel field housing unit



Preferably position the unit such that the cable gland is oriented towards the bottom or horizontally to reduce moisture penetration.

This signal converter is available as a model for wall or 2" pipe mounting with 1/4 NPT pneumatic connections, and as a model that can be directly flanged to pneumatic devices.

A stainless steel mounting bracket is available as a loose accessory for the wall or 2" pipe mounting model.

The second model is directly flanged to pneumatic devices using the two 6.7 mm mounting holes in the base. With this, the pneumatic connection of the air supply and output is achieved. **Observe the position of the two 1.6 mm holes.** The air transitions have to be sealed on the pneumatic device side, e.g. by recesses with inserted O-ring seals.

Both housing types are environmentally ruggedized and are suitable for outdoor installation without requiring further protection.

4 Connecting

4.1 Electrical connection



When making the electrical installation observe:

- the relevant regulations and safety standards pertaining to the installation and operation of electrical systems.
- the additional regulations, standards and directives governing the installation and operation of explosion-proof systems, if explosion-proof devices are used.
- the specifications in “Technical Data”. For explosion-proof devices also observe the specifications in the explosion protection certificate.

Do not run signal cables close to power lines. Power lines produce interference in their near vicinity which impairs the signals transmitted on the line.

Exclusively use cable glands with full Ex-d approval for EEx d operation (partly approved cable glands labeled “U” are NOT sufficient).

Fix the screwed-in Ex-d cable gland with glue to secure it against loosening. Loctite 242/243 or similar glues are suitable.

A 2-pole screw-terminal for cables with a max. cross-sectional area of 2.5 mm² is used for making the electrical connection. Do not reverse polarity when connecting the cable.

The screw-terminal of the control room housing unit is located on the side of the device, and the one of the field housing unit is accommodated inside the housing, i.e. the field housing must be opened for connecting the cable.

Cable entries of different types are provided:

standard or EEx ia or Ex N	Pg 13.5 cable gland
EEx d	M 20x1.5 ¹ thread
FM/CSA "intrinsically safe" or "explosion proof"	1/2 NPT thread

-
1. a cable gland with Ex certificate INIEX 88B. 103. 748 can be delivered as a loose part for EEx d (see "Accessories" in Section "Ordering information" of data sheet 10/18-0.11 EN).

4.2 Pneumatic connection



The supply air must be free of oil, water and dust in accordance with DIN/ISO 8573-1, Class 3. The dew point must be 10 K below the minimum operating temperature.

The control room housing has external 1/8 NPT holes for connecting the air pipes (for air supply and output). The model with field housing for wall or 2" pipe mounting has external 1/4 NPT holes.

The recommended pipe dimension is 6 x 1 mm. Dust, splinters or any other particles must be blown off the pipe before connecting. The connections for air supply and output are marked accordingly.

Flange-mounting the signal converter model for direct attachment to a pneumatic device at the same time establishes the pneumatic connection. We recommend to insert filters (sintered disks) into the air ducts near the signal converter. Experience has shown that residual dirt in the air ducts or outer pipes may lead to malfunctions.

The supply pressure for the signal converter has to be set to 1.4...10 bar, as required.

5 Commissioning

The signal converter is ready for operation immediately after installation and connection. No further adjustment is required.

6 Maintenance

The signal converter is maintenance-free. Note that the supplied instrument air must be free of oil, water and dust according to DIN/ISO 8573-1 to ensure trouble-free operation.

It is recommended to check on a regular basis the built-in textile filter (if existing) for the degree of pollution and the signal conversion to see if the values are still within the tolerance.

6.1 Checking / replacing the air filter



Warning

Switch off the air supply before replacing the filter element.

The air filter only exists for models with field housing for wall mounting or 2" pipe mounting.

If the supply air for the signal converter has not been conditioned properly (supplied air must be clean and dry in accordance with DIN/ISO 8573-1), the built-in textile filter protects the sensitive air nozzles and throttles from being obstructed with dirt. However, the filter capacity suffices only for occasionally collecting little dirt. In case of a pollution over a longer time the filter gets choked.

To check the degree of filter pollution first open the screw and then remove the filter element using tweezers (see Fig. 2 on page 14). Spare filter elements are available from us under catalog number 7942511.

The signal converter is ready to operate immediately after the filter element has been replaced. No further measures - like readjustment - are required.

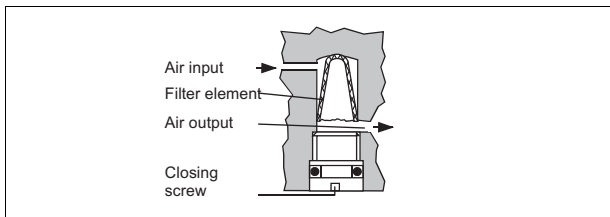

Fig. 2 Air filter (sectional drawing)

6.2 Readjusting the signal converter

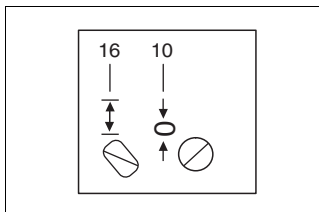

Fig. 3 Adjustment screws

The signal converters are delivered in an adjusted condition.

After longer operating periods, however, the tolerance limits may be exceeded due to aging or drift. This can be eliminated by re-adjustment.

The signal converter can be readjusted by using the two adjustment screws marked "> o <" for zero (10) and "<->" for span (16). When using a field housing unit first remove the cover to access the screws.

7 Technical data

Input

Signal range

0...20 mA or 4...20 mA

Input resistance

$R_i = 260 \text{ ohms at } 20 \text{ }^\circ\text{C, } T_k + 0.4 \text{ \%}/\text{K}$

Overload limit

30 mA (see specifications "Explosion protection" for Ex devices)

Capacitance/Inductance

negligible

Output

Signal range

0.2...1 bar or 3...15 psi

Air capacity

at supply pressure	kg/h	Nm ³ /h	scfm
1.4 bar / 20 psi	0.05	0.041	0.024
2.0 bar / 30 psi	0.07	0.057	0.033
4.0 bar / 60 psi	0.10	0.082	0.048
6.0 bar / 90 psi	0.16	0.130	0.076
10.0 bar /150 psi	0.25	0.205	0.120

Air supply

Instrument air

free of oil, water and dust to DIN/ISO 8573-1

Supply pressure

1.4...10 bar or 20...150 psi

Air consumption

equivalent to air capacity

Transmission data and influences

Characteristic

linear, direct or reverse action

Deviation:

$\leq 0.5\%$

Hysteresis:

$\leq 0.3\%$

Dead band:

$\leq 0.1\%$

Temperature

$\leq 0.1\%$ / K between -20 and +85 °C

$\leq 0.2\%$ / K between -55 and -20 °C

Air supply pressure

$\leq 0.8\%$ at 1.4...2 bar/20...30 psi

$\leq 0.8\%$ at 2...3 bar/30...45 psi

$\leq 0.5\%$ at 3...10 bar/45...150 psi for every 1 bar/15 psi

Mechanical vibration

$\leq 1\%$ up to 10 g and 10...80 Hz

Seismic vibration

meets requirements to DIN IEC 68-3-3 class III for strong and strongest earthquakes

Mounting orientation

$\leq 0.5\%$ at 90 ° change

EMC

meets EMC directive 89/336/EEC as of May 1989

(increased EMI shielding to EN 50082-2 (PR) as of 11/93)

CE marking

meets the EC directive for the CE certificate of conformity

Environmental capabilities

Climate class

GPF or FPF to DIN 40040

Temperature

-40....+85 °C or -55...85 °C

Relative humidity

75 % average, 95 % short-time, non-condensing

Observe the following limits:

1. For operation in hazardous areas observe the max. temperature limits specified under "Explosion protection".
2. For operation in hazardous areas and temperatures below -20 °C observe the special mounting conditions specified in the explosion protection certificate.

Explosion protection

ATEX, intrinsically safe 2G EEx ia IIC T4/T5/T6, Tüv 1487 x

ATEX, flameproof enclosure, EEx d IIC T4/T5/T6

CENELEC, intrinsically safe (all models)

EEx ia IIC T4/T5/T6, PTB No. Ex-93.C.2104X

CENELEC, flameproof (only for field housing units)

EEx d IIC T4/T5/T6, BVS No. 90.C.2016X

Observe the following limits for the temperature classes

Temperature class	Max. short circuit current	Max. ambient temperature
T6	50 mA	60 °C
T6	60 mA	55 °C
T5	60 mA	70 °C
T5	100 mA	55 °C
T5	120 mA	45 °C
T4	60 mA	85 °C
T4	100 mA	85 °C
T4	120 mA	80 °C
T4	150 mA	70 °C

BRITISH Standards (only for "field housing" unit)

Ex N II T6 for Zone 2, Certificate SSA 914012

FM "intrinsically safe" (only for "control room housing" units)

I.S.: CL I / Div 1 / Grp A B C D

N.I.: CL I / Div 2 / Grp A B C D

FM "intrinsically safe" (only for "field housing" units)

I.S.: CL I-II-II / Div 1 / Grp A B C D E F G

N.I.: CL I / Div 2 / Grp A B C

S.: CL II / Div 2 / Grp G

S.: CL III / Div 2

FM "explosion proof" (only for "field housing" units)

X.P.: CL I / Div 1 / Grp B C D

D.I.P.: CL II II / Div 1 Grp E F G

CSA "intrinsically safe" (only for "control room housing" units)

I.S.: CL I / Div 1 / Grp A B C D

CL I / Div 2 / Grp A B C D

CSA "intrinsically safe" (only for "field housing" units)

I.S.: CL I / Div 1 / Grp A B C D

CL II / Div 1 / Grp E F G

CL III

CL I / Div 2 / Grp A B C D

CL II / Div 2 / Grp E F G

CSA "explosion proof" (only for "field housing" units)

X.P.: CL I / Div 1 / Grp B C G

CL II / Div 1 / Grp E F G

Other explosion protection certificates on request

Control room housing unit

Material/protection

Aluminium housing, IP 20, with plastic cap

Mounting

Rail EN 50022 - 35 x 7.5
 EN 50035 - G 32
 EN 50045 - 15 x 5

Electrical connection

2-pole screw terminal for 2.5 mm²

Pneumatic connection

two 1/8 NPT threads for air supply and output

Mounting orientation: any

Weight

0.25 kg

Dimensions

see dimensional drawing

Aluminium/stainless steel field housing unit

Material/protection

Aluminium or stainless steel housing, IP 65
(aluminum housing with two-component varnish,
color: blue (RAL 5010))

Mounting

Wall mounting or 2" pipe mounting
with separate stainless steel mounting bracket
or
two 6.7 mm holes at add-on module for OEM application

Electrical connection

2-pole screw terminal for 2.5 mm² in housing
with PG 13.5 cable gland
for "standard", "CENELEC intrinsically safe"/ATEX EEx d
and for "BRITISH Standards Ex N"

Electrical connection (continued from previous page)

with M 20x1.5 thread

for "CENELEC EEx d"/ATEX EEx d

(on request cable gland with Ex d certificate as accessory)

with 1/2 NPT thread for cable entry

for FM/CSA/ATEX EEx d

Pneumatic connection

two 1/4 NPT threads for air supply and output

or

two lateral 1.6 mm holes on add-on module

Mounting orientation

any

Weight

0.62 kg with aluminium housing

1.20 kg with stainless steel housing

Dimensions

see dimensional drawing

Spare parts

Except for the textile filter, the signal converter is wear free and does not require maintenance. Therefore, filter elements are the only spare parts that should be kept on stock (refer to Section "Maintenance" for the catalog no.)

8 Dimensional drawings, conn. diagrams

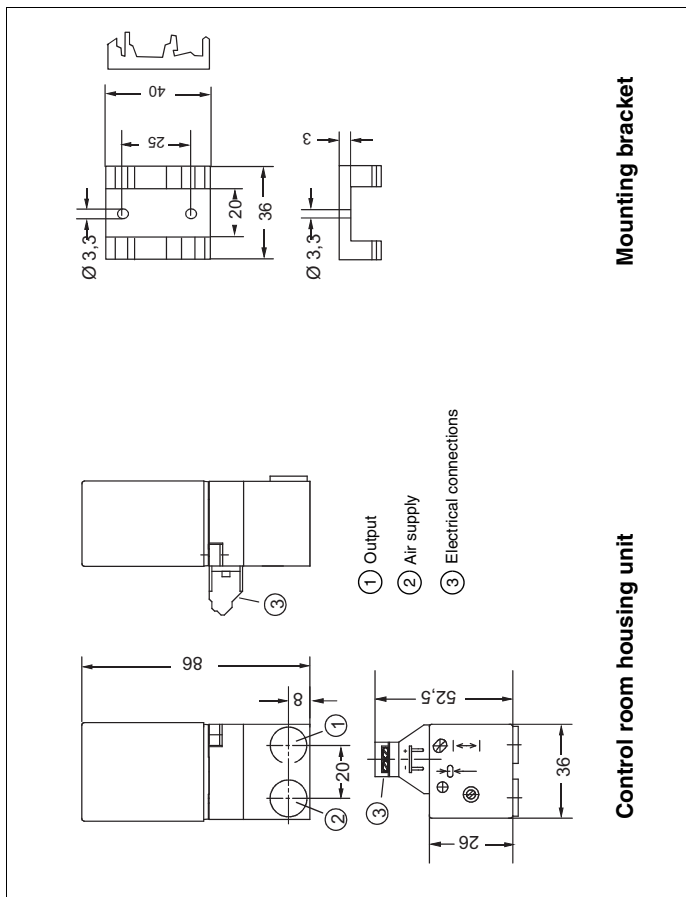

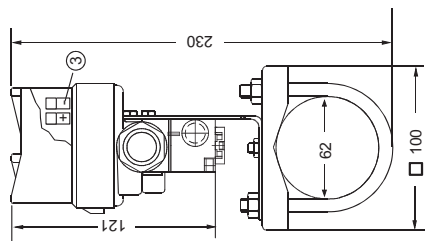

**Aluminum or stainless steel
field housing unit
for wall or 2" pipe mounting**

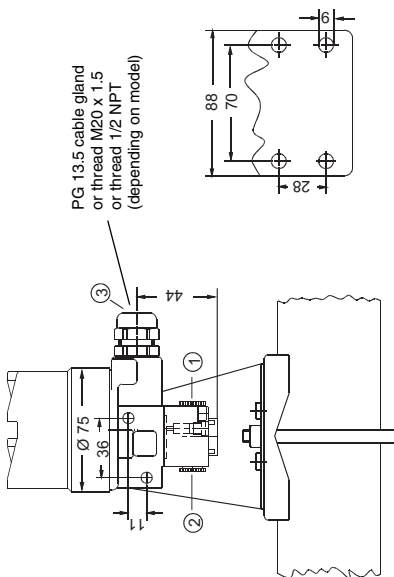

PG 13.5 cable gland
or thread M20 x 1.5
or thread 1/2 NPT
(depending on model)

**Profile sheet metal
for wall mounting**

- ① Output
- ② Air supply
- ③ Electrical connections

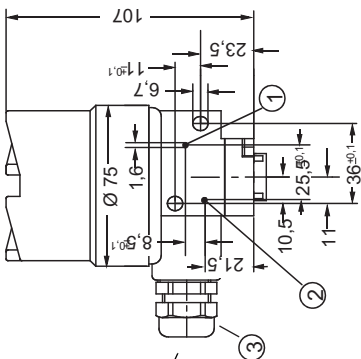

PG 13.5 cable gland
or thread M20 x 1.5
or thread 1/2 NPT
(depending on model)

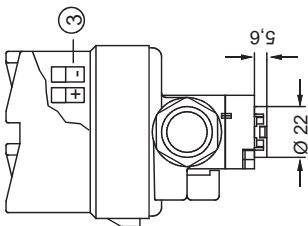

① Output

② Air supply

③ Electrical connection

**Aluminum or stainless steel housing unit
as add-on module for OEM applications**

Subject to technical changes.

This technical documentation is protected by copyright. Translating, photocopying and disseminating it in any form whatsoever - even editings or excerpts thereof - especially as reprint, photomechanical or electronic reproduction or storage on data processing systems or networks is not allowed without the permission of the copyright owner and non-compliance will lead to both civil and criminal prosecution.



ABB Automation Products GmbH

Schillerstraße 72
32425 Minden, GERMANY
Tel: +49 571 830-1494
Fax: +49 571 830-1860

Subject to technical changes
Printed in the Fed. Rep. of Germany
42/18-61 EN Rev. 02
Edition 09.02