

Actuators & Positioners

Characterizable Pneumatic Positioners

Series AV1/2/3

- **Proven pilot valve** - Increased reliability minimizes downtime and maintenance costs.
- **High capacity** - Standard model has high delivery capacity. Performance Series increases speed of response even more.
- **Performance Series** - High flow gain pilot valve body achieves maximum flow capacity at small error signal.
- **Position transmitters** - 4-20mA position transmitters.
- **Compact rugged design** - NEMA 4X version available.
- **High vibration and shock environments** - Withstands vibration and shock at frequencies to 120 Hz and accelerations to 2 G.
- **Fast, accurate calibration** - Independent zero and span adjustments
- **Single or double-acting without additional hardware** - Controls single and double-acting, linear and rotary actuators.
- **Vent design allows natural gas operation**
- **Type AV27 positioner available with explosionproof I/P converter**



Series AV1/2/3
Pneumatic Positioners

Characterizable Pneumatic Positioners

Type AV Characterizable Pneumatic Positioners are control devices that satisfy a wide range of applications. They provide fast, sensitive, and accurate positioning of pneumatic signal or double-acting, linear or rotary motion actuators. A mechanical connection from the actuator to a position feedback cam in the positioner establishes actual position. Three characterized segments on one cam provide application flexibility by establishing various relationships between input signal and actuator position. The relationships provided by the segments are square foot, linear, and square.

Using the cam and the zero, span and gain adjustments, the actuator responds with characteristics specific to an application.

An optional manifold assembly provides an integral shutoff and equalizing valve. This isolates the positioner from a double-acting actuator (with manual override) without removing the positioner from the process. The manifold also provides disposable filter cartridges that insure fast servicing and minimum downtime. Manifolds also contain three gage ports for mounting one instrument and two output gages. A supply gage is available and must be piped into the supply line by the customer.

Type AV1 positioners are pneumatic positioners that use a pneumatic input to control the pneumatic output. Type AV2 and AV3 positioners are electropneumatic, with Type AV2 and AV3 using an I/P (current-to-pneumatic) converter to accept a four to 20-milliampere input signal and convert it to a pneumatic output.

Some nomenclature options include a high temperature Type AV1 positioner that can be operated and stored at temperatures up to 127 degrees celsius (250 degrees Fahrenheit). Type AV2 positioners are available with an explosionproof I/P converter, external to the housing, that is mounted on an adapter block manifold. The performance series provides a high flow gain pilot valve body having square ports that provide a maximized air flow for a small motion of the valve stem.

Common Specifications

Standard stroke range
(cam selection)¹

AV__1_____	12.7 to 50.8 mm (0.5 to 2.0 in.) linear, rotary input 45°
AV__2_____	25.4 to 101.6 mm (1.0 to 4.0 in.) linear, rotary input 90°

Gain Two adjustment levels via gain hinge spring change. Refer to Figure 1 and 2 for standard and performance series (high gain) units.

Supply pressure² 172 to 1,034 kPa
(25 to 150 psig)

Supply pressure effect 0.05% per 6.9 kPa for
±69 kPa change
(0.05% per 1.0 psig for
±10 psig change)

Air consumption Refer to figure 1

Capacity Maximum capacity ex
hausted to atmosphere.
Refer to Figure 2

Vibration effect³ <2,0% error for:
5 to 115 Hz at peak-to-peak
constant displacement to
4mm (0.16 in.)
15 to 120 Hz at acceleration
to 2 G.

Pneumatic Connections 1/4 NPT on supply, signal, and
output connections
1/8 NPT on pressure gages

Materials of construction

Enclosure	Aluminum and <0.5% magnesium
Pilot Valve	303 stainless steel

Enclosure classification

Standard	NEMA 3R classification when vent hole is protected from rain using rain elbow (1/2-NPT street elbow, Fig. 3)
----------	--

AV_____N NEMA 4X (See Page 8)

Notes:

1. Use 90° cam whenever possible.
2. Minimum supply pressure should be 34.4 kPa (5.0 psig) above operating pressure required
3. Tested according ISA-S75, 13 - 1989

Type AV1 Positioner Specifications

Input range¹

AV11 and AV15	20.7 to 103.4 kPa (3.0 to 15.0 psig)
AV12 and AV16	20.7 to 186.2 kPa (3.0 to 27.0 psig)

Accuracy² 0.80% of span maximum

Resolution 0.09% of span maximum

Hysteresis² 0.45% of span maximum

Repeatability² 0.12% of span maximum

Deadband² 0.12% of span maximum

Linearity² 0.70% of span maximum

Weight 1.84 kg (4.06 lb)

Temperature limits

Operating AV11/2	-40°C to 82°C (-40°F to 180°F) ³
AV15/6	-20°C to 127°C (-4° to 250°F) ³

Storage AV11/2	-40°C to 93°C (-40°F to 200°F)
AV15/6	-20°C to 127°C (-4°F to 250°F) ²

Humidity limits Operating and storage:
0% to 95% noncondensing

Type AV2 Positioner Specifications

Input range¹ 4 to 20mA

Input impedance

Nominal	215Ω at 22°C (72°F)
Maximum	245 Ω at 60°C (140°F)

Accuracy² 0.90% of span maximum

Resolution 0.30% of span maximum

Hysteresis² 0.70% of span maximum

Repeatability² 0.50% of span maximum

Deadband² 0.30% of span maximum

Linearity² 0.70% of span maximum

Weight 2.32 kg (5.11 lb) standard,
2.95 kg (6.51 lb)
explosionproof

Temperature limits Operating and storage:
-20°C to 82°C
(-4°F to 180°F)³

Humidity limits Operating and storage:
0% to 95% noncondensing

Note:

1. Units have 50% range suppression and/or zero elevation capability.
2. Tested according to ISA-S75. 13-1989.
3. For operation below 4.4°C (40°F), dew point of supply air must be 10°C (18°F) lower than lowest expected operating temperature.

Type AV3 Positioner Specifications

Input range ¹	4 to 20 mA (30 VDC maximum)
Input impedance	<1.66 Ω at 4 mA <0.57 Ω at 12 mA <0.35 Ω at 20 mA
Accuracy ²	0.90% of span maximum
Resolution	0.30% of span maximum
Hysteresis ²	0.60% of span maximum
Repeatability ²	0.60% of span maximum
Deadband ²	0.30% of span maximum
Linearity ²	0.80% of span maximum
Weight	2.27 kg (5.00lb)
Temperature limits ³	
Operating	-20°C to 60°C (-4°F to 140°F) ⁴
Storage	-20°C to 80°C (-4°F to 176°F)
Temperature effect ²	<0.18% per °C (<0.09% per °F)
Humidity limits	Operating and storage: 0% to 95% noncondensing
RFI effect ²	±1.5% maximum at 10 V/m field strength, 20 to 540
MHz	

Type AV1/2/3_ _ _1 Position Transmitter Specifications

Total resistance	2000 Ω, ±20% potentiometer
Power rating	1 W up to 70°C (158°F), 0 W at or above 125°C (257°F)
Wiper rate of change	9.9 Ω nominal per degree of cam rotation
Temperature effect	0.05% (500 ppm) per °C (0.03% (278 ppm) per °F) maximum
Maximum voltage	35 VDC or 30 VAC across the potentiometer ends
Temperature limits	
Operating	-40°C to 82°C (-40°F to 180°F)
Storage	-40°C to 93°C (-40°F to 200°F)

Notes:

1. Units have 50% range suppression and/or zero elevation capability.
2. Tested according to ISA-S75. 13-1989
3. Operation below specification will increase stroke time.
4. For operation below 4.4°C (40°F), dew point of supply air must be 10°C (18°C) lower than lowest expected operating temperature.

Accessories

Mounting Kits, for diaphragm actuators with yoke mounting bosses (includes mounting bracket, linkage and hardware)

- For stem size 0.375 to 0.75 inch (9.53 - 19.1 mm), adjustable stud length 2.687 inch (68.2 mm) - Pt. #5327321_12
- For stem size 0.75 to 1.0 inch (19.2 - 25.4 mm), adjustable stud length 3.437 inch (87.3 mm) - Pt. #5327321_13
- For stem size 0.375 to 1.0 inch (9.53 - 25.4 mm), adjustable stud length 3.406 inch (86.5 mm) - Fisher - Pt. #5327321_14

Mounting Bracket, for reciprocating valves (contained in above kits) - Pt. #5400266_1

Connecting Link, adjustable length 12 inch (304.8 mm) contained in above kits - Pt. #5312449__4

Mounting Kits, for retrofitting UP Drives from AP to AV Positioners

- For UP10, UP20 - Pt. #5400309_1
- For UP30, UP40 - Pt. #258493_1
- For UP50, UP60 - Pt. #258494_1

Mounting Kits, for retrofitting AC Drives from old Bailey Fischer & Porter Part Number Positioners to AV Positioners

- For AC0404 - Pt. #258527_1
- For AC0608 - Pt. #258528_1
- For AC0816 - Pt. #258529_1
- For AC1016 - Pt. #258530_1

Mounting Kits, for retrofitting AC drives from AP to AV Positioners

- For AC0404 - Pt. #258527_1
- For AC0608 - Pt. #258528_1
- For AC0816 - Pt. #258529_1
- For AC1016 - Pt. #258530_2

Mounting Kits, for adding a Beacon™ Indicator or a limit switch package, onto the cover of an AV Positioner

- For adding a Beacon™ Indicator (includes a Westlock black & yellow Indicator) - Pt. #258570_1
- For adding Limit Switches, Westlock 2004 or Equivalent (does not include Limit Switch Package) - Pt. #258570_2
- For adding Limit Switches, Westlock 2007 or Equivalent (does not include Limit Switch Package) - Pt. #258570_4

Speed Control Orifices, used when more than one final control element is being operated from the same control signal. Designed to equalize speeds between units.

- 0.040 inch (1.016mm) - Pt. #5327327_1
- Blank (drilled as required) - Pt. #5327327_2

Pressure Gages, for Calibration

- Instrument - 0-30 psig range - Pt. #5326605_4
- Supply - 0-160 psig range - Pt. #5326605_5
- Output - 0-160 psig range - Pt. #5326605_6

Note: The optional manifold/gage block provides gage ports - one for instrument (internal input signal) and two output gages. A supply gage can be installed in the supply line (piping by customer).

External By Pass Valve for Single Acting Diaphragm Applications only -

- Permit transfer of pneumatic control signal directly to diaphragm so that final control element can be operated while the positioner is being serviced. Use with AV1__1__ only. - Pt. #5326945_1

Supply Air Regulator

- Maximum inlet pressure - 250 psi, 1/4 NPT - Pt. #1951029_5

Supply Air Filter

- Maximum inlet pressure - 150 psi, 1/4 NPT - Pt. #5328563_1

Spare Parts/ Parts Kits: (AV1 thru AV4 except as noted)

Diaphragm Parts

- Diaphragm Assembly Kit (3-15 psig and 3-27 psig) - Pt. #258486_1
- 3-15 psig Positioner, Diaphragm cover - Pt. #5400295_1
- 3-27 psig Positioner, (AV1 only), Diaphragm cover - Pt. #5400295_2

Note: When converting a 3-15 Positioner to a 3-27 Input Positioner, or vice versa, both the Diaphragm Assembly Kit and the appropriate Diaphragm Cover are required.

Manifold Parts

Manifold Kit for field addition - Pt. #258491_1
 Filter Replacement Kit - Pt. #258487_1
 Shut Off Valve Kit - Pt. #258270_1

Explosion-Proof Positioner Parts (AV27)

Kit to Mount Explosion-proof I/P Converter to
 Pneumatic Positioner (does not include I/P) -
 Pt. #258612_1
 IP Converter for AV27 (for replacement or to make
 an AV27 in field, requires above kit) -
 Pt #1949547_2

Gage Block Kit for Field Addition - Pt. #258569_1

I/P Converter Replacement Kit (for AV23 only) -
 Pt. #258477_1

Regulator Assembly (for AV2 only) - Pt. #1951745_1

Characterizing Cams

Forward-acting full rise cam, 90 degree rotation -
 Pt. #5400281_1
 Reverse-acting full rise cam, 90 degree rotation -
 Pt. #5400281_2
 Forward-acting half rise cam, 45 degree rotation -
 Pt. #5400298_1
 Reverse-acting half rise cam, 45 degree rotation -
 Pt. #5400298_2
 Blank Cam, for custom shaping -
 Pt. #5400277_1

Pilot Valve Assembly Kit - Pt. #258488_1
 Pilot Valve Assembly Kit (Performance Series,
 AV_____P) - Pt. #258488_3
 Pilot Valve Assembly Kit
 (High Temp. Model, AV15/16) Pt. #258488_2
 Pilot Valve Assembly Kit (High Temp & Performance
 Series Model, AV1 5/6_____P) -
 Pt. #258488_4

Feedback arm for linkage attachment, for 90 degree
 cam rotation - Pt #5327445_1
 Feedback arm for linkage attachment, for 45 degree
 cam rotation - Pt. #5327445_2

Cover Assembly (includes cover, window, gasket and
 plastic cover inserts) - Pt. #258545_1

Cam Follower Arm Assembly - Pt. #258544_1

Position Transmitter - Field Addition Kits
 Pneumatic Position Transmitter -
 Pt. #258492_1

Cam Shaft

1/2 inch Square End Connection -
 Pt. #5400278_1
 Tapered End Connection for Linear Feedback Arm
 Pt #5400287_1
 0.342 inch Square End for Older DeZurik/K&M
 Actuators - Pt. #5400287_2
 0.250 inch Flats (UP1 / UP2 after 8/95) -
 Pt. #5400287_3
 ■ 0.375 inch Square End (For DeZurik PowerRac
 Actuators) - Pt. #5400287_4
 ■ 0.156 inch (4 mm) Flats (For Namur Rotary
 Mounting) - Pt. #5400287_5
 ■ Also required conversion plate -
 Pt. #5400321_1

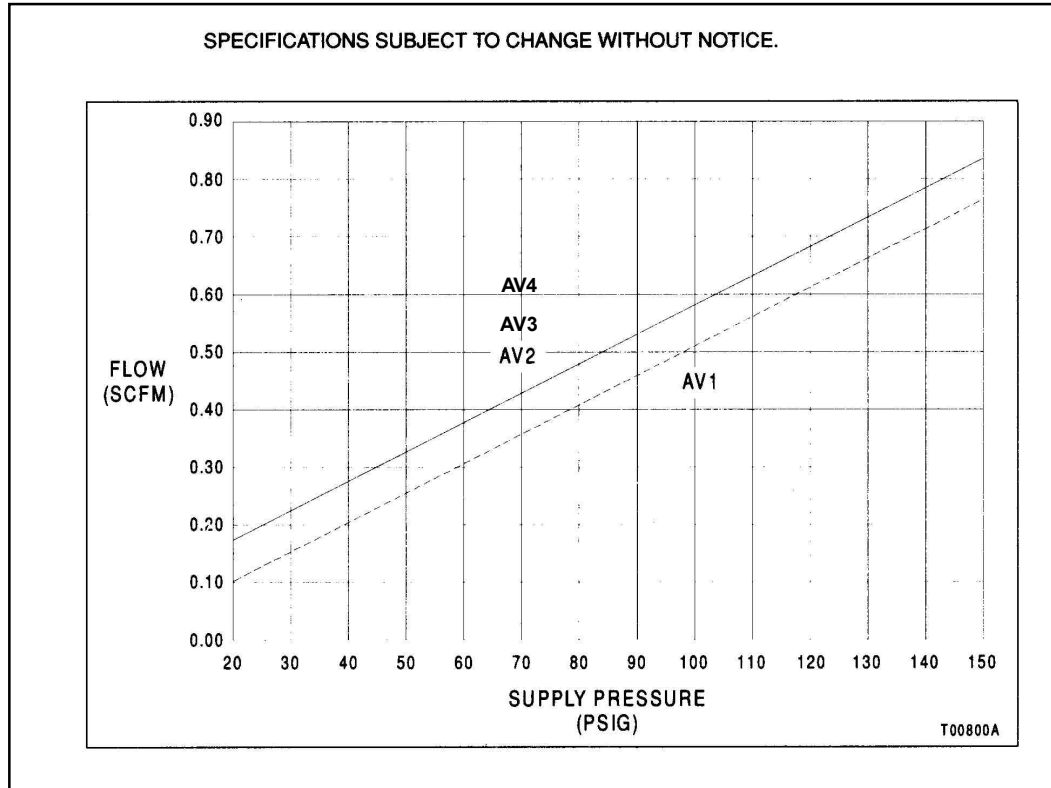

Figure 1. Air Consumption (at Null)

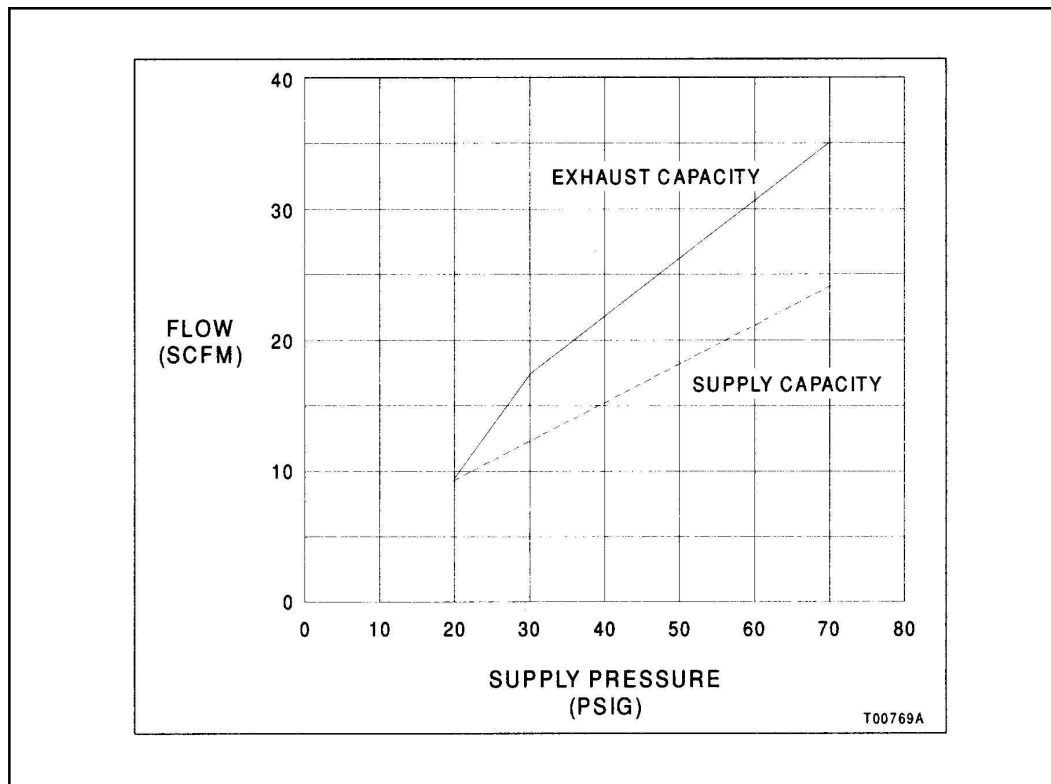

Figure 2. Capacity (Exhaust to Atmosphere)

Operation

Type AV positioners operate by balancing opposing forces. Figure 4 is an operational diagram of the positioner. A balance beam, hinged at one end and connected to the pilot valve at the other, is acted upon by two forces:

- Upward force of the signal diaphragm assembly
- Downward force from the range spring.

A change in input signal changes the force exerted by the signal diaphragm, moving the balance beam, in turn moving the pilot valve. The pilot valve supplies and/or exhausts air to the actuator that ultimately changes its position. The change in actuator position is fed back to the positioning cam. The positioning cam moves, changing the tension of the range spring until a balanced condition once again exists.

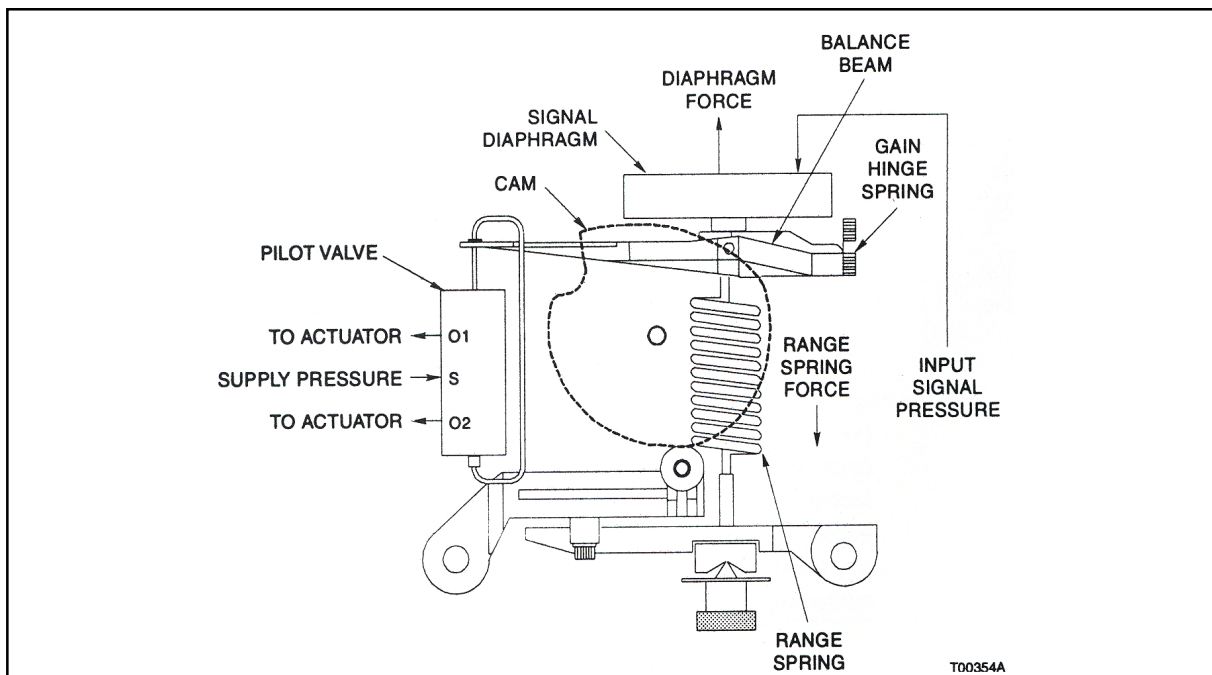

Figure 4. Operation Diagram

The input signal pressure determines the diaphragm force. The Type AV1 positioner uses an external input pressure (either 20.7 to 103.4 kilopascals (3.0 to 15.0 pounds per square inch gage) or 20.7 to 186.2 kilopascals (3.0 to 27.0 pounds per square inch gage)). Types AV2 and AV3 positioners internally generate the input signal pressure using an I/P converter.

The range spring force is a function of the shape and position of the cam. The cam is coupled to the cam shaft that is connected through linkage (or coupling) to the actuator. Therefore, range spring tension is a function of the actuator position.

Type AV1 Pneumatic Positioner

The Type AV1 positioner receives an external pneumatic signal and converts it to a pneumatic output. This output produces the motive force that positions the power actuator.

Type AV2 and AV3 Four to 20-Milliampere I/P Positioners

The Type AV2 and AV3 positioners receive a current input (four to 20 milliampere) from the control device and convert the signal to pneumatic signal. This pneumatic signal is converted to a pneumatic output that produces the motive force that positions the actuator. The Type AV2 fails open/closed and the Type AV3 fails in place on loss of current input signal.

Position Transmitters

Two types of position transmitters are available on Type AV1, AV2 and AV3 positioners.

The potentiometric position transmitter uses a high durability plastic film potentiometer to indicate the position of the cam shaft. The resulting resistive value is a function of the shaft position. The resistive output can be used for additional control purposes. Refer to Type AV1/2/3_1 Position Transmitter Data Sheet.

The four to 20-milliamper position transmitter uses a high durability plastic film potentiometer to indicate the cam shaft position. The resulting resistive value is sent to an electronics assembly that produces a proportional four to 20-milliamper signal. This signal can be used for additional control purposes. Refer to Type AV_2 Position Transmitter Data Sheet.

Performance Series

The performance series provides a high flow gain pilot valve body with square ports that provide maximized air flow for a small motion of the pilot valve stem. A relatively small error signal can therefore cause a relatively large change in output air flow to the actuator. This feature is useful when driving larger actuators that might otherwise be insensitive or slow to respond to small signal changes.

Compared to other positioners on the market, the standard Type AV positioners have a high delivery capacity. The flow gain curves shown in Figures 5 and 6 show output air flow versus input error signal for the standard and high gain performance series positioners.

Figures 5 and 6 show that the large signal maximum air flow for both the standard and performance series positioners is about the same. The performance series positioners achieve maximum flow capacity at a much smaller error signal. Avoid using a performance series positioner on a small actuator, as it could cause instability.

Explosionproof I/P Converter

The Type AV27 positioner employs an explosionproof I/P converter that is mounted to an adapter block manifold. The adapter block manifold is bolted to the outside of the main positioner housing. The unit is a Type AV12 positioner with the electric to pneumatic (four to 20-milliamper to 20.7 to 103.4-kilopascal (3.0 to 15.0 pounds per square inch gage)) conversion occurring within the externally mounted I/P converter.

The four to 20-milliamper input signal wires shall be connected through an explosionproof conduit entrance on the I/P converter. If no electrical connections are made within the main housing, the entire positioner can be considered suitable for application in the hazardous locations shown on the I/P label. Refer to Figure 3 for the external and mounting dimensions of the positioner.

NEMA 4X

The positioner is available with a NEMA 4X housing. To maintain the NEMA 4X classification, the positioner shall meet special installation requirements described in the NEMA 4X mounting kit. Suitable piping shall be attached to the vent opening and vented in a manner to preclude the entrance of water under pressure, as from a hose. Additionally, the conduit connections shall be suitable for a NEMA 4X rating.

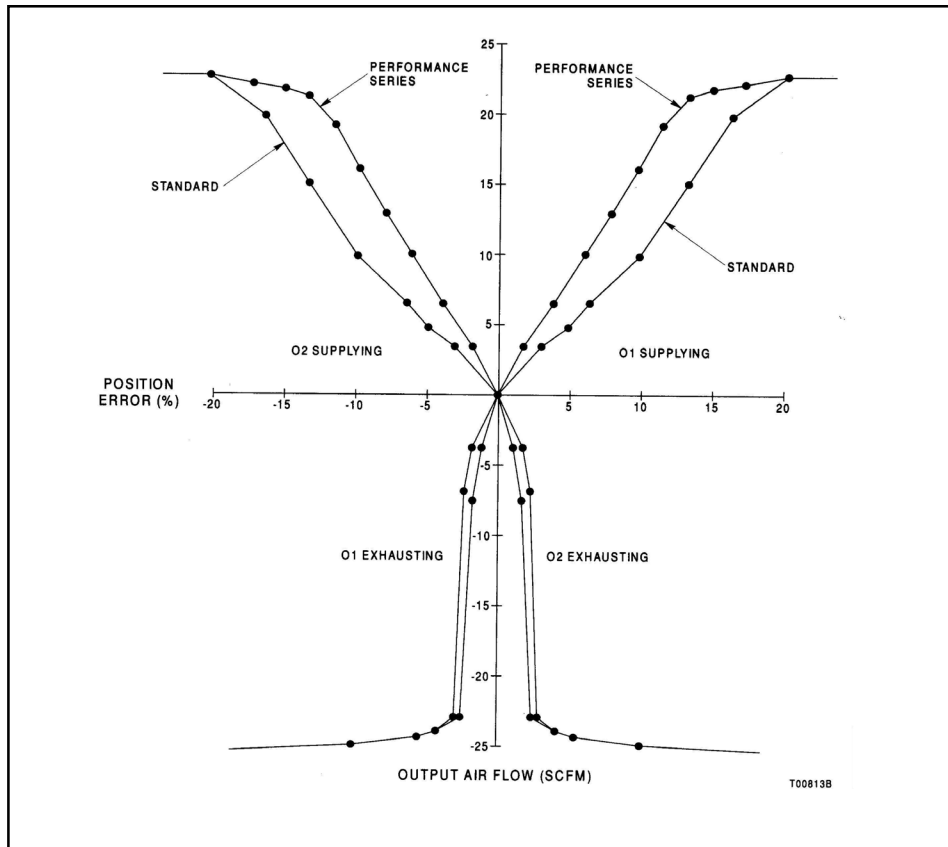

Figure 5. Output Air Flow Versus Error Signal - Standard and Performance Series

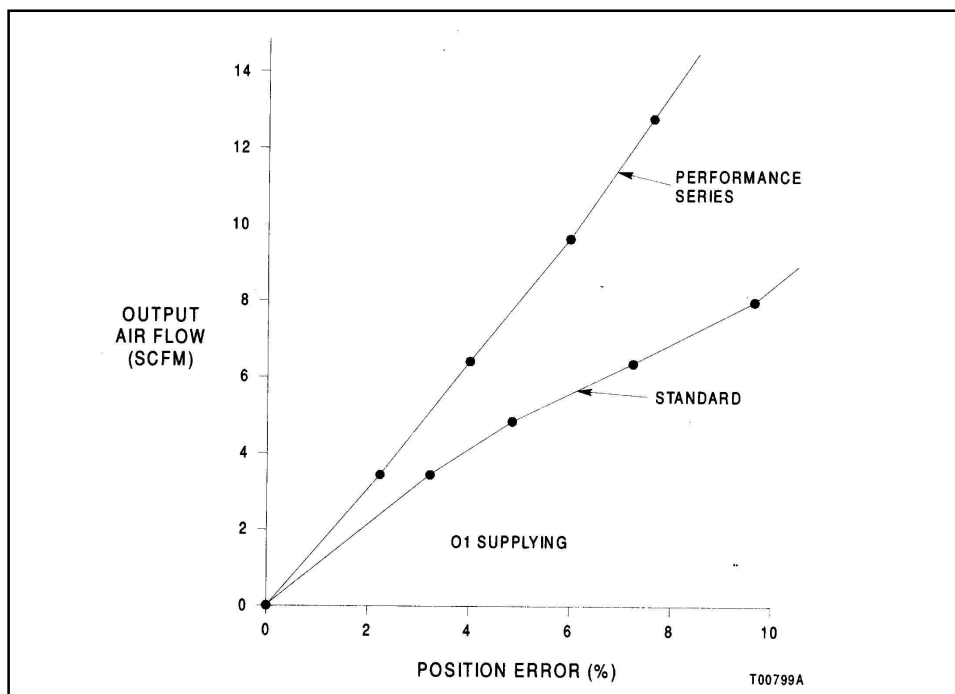

Figure 6. Expanded First Quadrant View of Figure 4

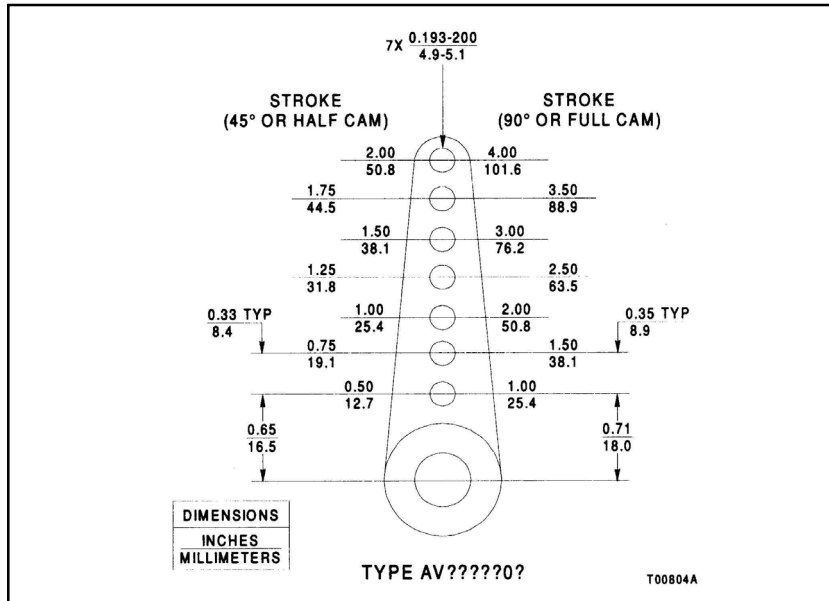

Figure 7. Drive Arm Connections

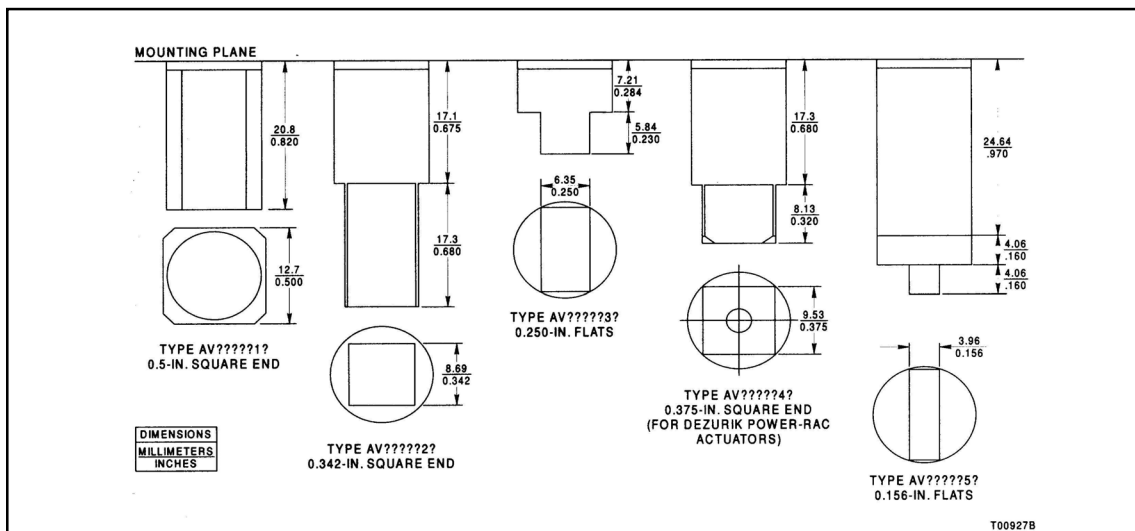

Figure 8. Drive Shaft Variations

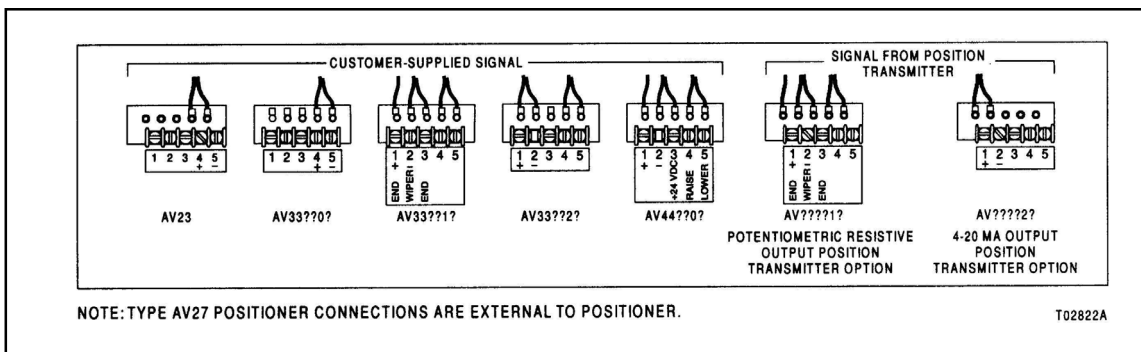

Figure 9. Electrical Connections

Agency Approvals

Nomenclature	Approval/Certification ^{1,2}	
All	Factory Mutual Research (FM) Approved as nonincendive for: Class I, Division 2, Groups A, B, C, and D Class II, Division 2, Groups F and G Class III, Division 2 Approved as intrinsically safe for: Class I, Division 1, Groups A, B, C and D Class II, Division 1, Groups E, E and G Class III, Division 1	Canadian Standards Association (CSA): Certified as: Class I, Division 2, Groups A, B, C, and D Class II, Division 2, Groups E, F, and G Class III, Division 2 Certified as intrinsically safe for: Class I, Division 1, Groups A, B, C, and D Class II, Division 1, Groups E, F, and G Class III, Division 1
AV27__0__	Factory Mutual Research (FM): Approved as explosionproof for: Classes I, II; Division 1, Groups B,C,D,E, F, and G	Canadian Standards Association (CSA): Certified a explosionproof for: Classes I, II; Division 1, Groups B,C,D,E, F, and G
All	This product complies with all applicable European Community product requirements , and specifically with those required to display the CE marking on the product nameplate.	

Notes:

1. Hazardous locations approvals for use in flammable atmospheres are for ambient conditions of -25°C to 40°C (-13°F to 104°F), 86 to 106 kPa (12.5 to 15.7 psig) with a maximum oxygen concentration of 21%.
2. For installing the positioner in a hazardous location, refer to: Product Application Guide, Installing a Type AV Positioner in a Hazardous Location.

Accessories

Accessory	Description
Mounting kits	Kit number 5327321___. Dependent on valve stem size. Refer to Table 1 for ABB retrofit kits.
Speed control orifices	Regulate time constant of positioner and final control device. Orifices are installed directly into positioner output ports (Table 2). Speed adjustment can also be controlled by using the internal stroke adjustment screws.
Pressure gages	For reading signal, supply and output pressures (Table 3).
Blank cam	Part number 5400277_1. Used to characterize the positioner if the standard cams (square, linear, square root) will not produce the desired relationship. Blank cam must be profiled.
Supply air regulator	Refer to Table 4.
Air filters	Installs in supply air line to prevent particles from entering the positioner that can lead to malfunctions (Table 5)
Manifold filters	For addition or replacement of secondary air filters on manifold-equipped positioners. Kit number 258487?1.
Bypass valve Assembly (Type AV1__1 only)	Part number 5326945?1. External by pass valve for single-acting diaphragm applications only. Permits transfer of pneumatic control signal directly to diaphragm so that final control element can be operated while positioner is being serviced.

Table 1. Rotary Actuator Retrofit Mounting Kits

Kit Number	Drive Nomenclature	Retrofit Mounting Kit
5400309_1	UP1, UP2	Type AP positioner to
258493_1	UP3, UP4	Type AV positioner
25849_1	UP5, UP6	
258527_1	AC0404	ABB part number pilot valve positioner to Type AV positioner
258528_1	AC0608	
25852_1	AC0816	
258530_1	AC1016	
258527_1	AC0404	Type AP positioner to
258528_1	AC0608	Type AV positioner
258529_1	AC0816	
258530_2	AC1016	

Table 2. Speed Control Orifices

Part No.	Size mm (in.)
5327327_1	1.02 (0.04)
5327327_2	Blank (drill to suit)

Table 3. Pressure Gages

Part No.	Legend	Range	
		kPa	psig
5326605_4	Instrument	0 to 200	0 to 30
5326605_5	Supply ¹	0 to 1,000	0 to 160
5326605_6	Output	0 to 1,000	0 to 160

Note:

- Optional manifold provides gage ports, 1 for instrument (internal input signal), and 2 output gages. Supply gage can be installed in supply line (piping by customer).

Table 4. Supply Air Regulators with Gages

Part No.	Max. Outlet Pressure (psig)	Max. Inlet Pressure (psig)	Inlet/Outlet Connections
1951029_5	125	250	¼ NPT

Note:

Parker No. 05R113AD

Table 5. Supply Air Filters¹

Note:

- In-line coalescing filter for removal of solid and liquid contaminants in compressed air.

Mounting Kits

Tables 6, 7, and 8 list the parts identified in Figure 10 for the various mounting kits available.

Table 6. Mounting Kit Number 5327321_12¹ - Valve Stem Diameter 0.375 to 0.750 in. (Fig. 10)

Item	Part No.	Description	Item	Part No.	Description
1	5400266_1	Positioner mounting bracket	12	197120_5	Nut, elastic stop (2)
2	0.250-20 x 0.750	Screw, socket hd (3)	13	5311690_1	Adjustable stud, 2.69 in.
3	0.250	Lock washer, reg spring (3)	14	5311690_2	Adjustable stud, 3.43 in.
5	0.312-18 x 0.625	Cap screw, hex socket hd (2)	21	0.375	Lock washer, med spring (3)
6	0.312	Lock washer, reg spring (2)	22	0.375-24	Nut, hex jam
7	R6440-005	Type 347 stainless steel wire, 0.300 diameter, 6-in.	23	5311687_2	Stem clamp, 0.375 – 0.750- in. dia
8 ²	19934_248	Spacer	25	5311691_1	Clamp plate, 0.375 – 0.750- in. dia.
9 ²	0.190-32 x 1.125	Screw, pan hd machine	27	0.375-16 x 1.50	Screw, hex skt hd cap (2)
10	5312449_4	Connecting link, 12-in. (cut to fit)	28	0.375-16	Nut, hex jam (2)
11 ²	0.190-32 x 0.875	Screw, pan hd machine (2)	29	0.125 dia x 0.750	Groove pin, type 1

Note:

1. Positioner mounting kits for direct or reverse acting diaphragm actuators and single or double-acting piston actuators with linear (reciprocating) motion.
2. When fastening Item 10 to drive arm at first hole (nearest drive shaft), use Items 8 and 9 and omit 1 of Item 11.

Table 7. Mounting Kit Number 5327321_13¹ - Valve Stem Diameter 0.750 to 1.000 in. (Fig. 10)

Item	Part No.	Description	Item	Part No.	Description
1	5400266_1	Positioner mounting bracket	11 ²	0.190-32 x 0.875	Screw, pan hd machine (2)
2	0.250-20 x 0.750	Screw, socket hd (3)	12	197120_5	Nut, elastic stop (2).
3	0.250	Lock washer, reg spring (3)	14	5311690_2	Adjustable stud, 3.43 in.
5	0.312-18 x 0.625	Cap screw, hex socket hd (2)	21	0.375	Lock washer, med spring (3)
6	0.312	Lock washer, reg spring (2)	22	0.375-24	Nut, hex jam
7	R6440-005	Type 347 stainless steel wire, 0.300 diameter, 6-in.	24	5312483_1	Stem clamp, 0.750 – 1.00-in. dia.
8 ²	19934_248	Spacer	26	5312471_1	Clamp plate, 0.750 – 1.00 in. dia.
9 ²	0.190-32 x 1.125	Screw, pan hd machine	27	0.375-16 x 1.50	Screw, hex skt hd cap (2)
10	5312449_4	Connecting link, 12-in. (cut to fit)	29	0.125 dia x 0.750	Groove pin, type 1

Note:

1. Positioner mounting kits for direct or reverse acting diaphragm actuators and single or double-acting piston actuators with linear (reciprocating) motion.
2. When fastening Item 10 to drive arm at first hole (nearest drive shaft), use Items 8 and 9 and omit 1 of Item 11.

Table 8. Mounting Kit number 5327321_14¹ - For Use on Fisher Actuators - Valve Stem 0.375 to 0.750 in. (Fig.10)

Item	Part No.	Description	Item	Part No.	Description
1	5400266_1	Positioner mounting bracket	11 ²	0.190-32 x 0.875	Screw, pan hd machine (2)
2	0.250-20 x 0.750	Screw, socket hd (3)	12	197120_5	Nut, elastic stop (2).
3	0.250	Lock washer, reg spring (3)	14	5311690_2	Adjustable stud, 3.43 in.
5	0.312-18 x 0.625	Cap screw, hex socket hd (2)	21	0.375	Lock washer, med spring (3)
6	0.312	Lock washer, reg spring (2)	22	0.375-24	Nut, hex jam
7	R6440-005	Type 347 stainless steel wire, 0.300 diameter, 6-in.	24	5312483_1	Stem clamp, 0.750 – 1.00-in. dia.
8 ²	19934_248	Spacer	26	5312471_1	Clamp plate, 0.750 – 1.00 in. dia.
9 ²	0.190-32 x 1.125	Screw, pan hd machine	27	0.375-16 x 1.50	Screw, hex skt hd cap (2)
10	5312449_4	Connecting link, 12-in. (cut to fit)	29	0.125 dia x 0.750	Groove pin , type 1

Note:

1. Positioner mounting kits for direct or reverse acting diaphragm actuators and single or double-acting piston actuators with linear (reciprocating) motion.
2. When fastening Item 10 to drive arm at first hole (nearest drive shaft), use Items 8 and 9 and omit 1 of Item 11.

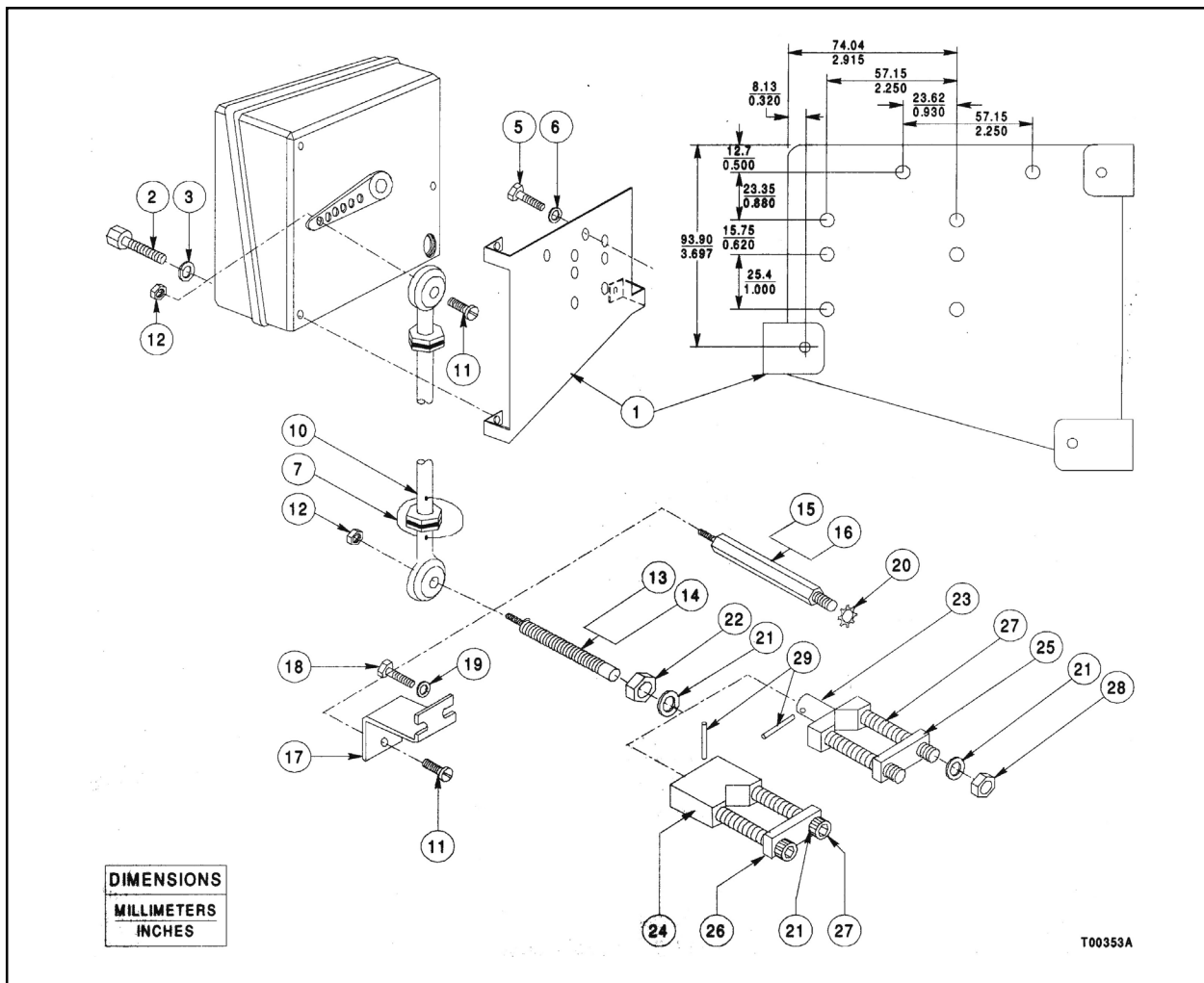

Figure 10. Mounting Kits

AV1

The Type AV1 Pneumatic Positioner accepts linear or non-linear pneumatic input signal ranges to provide sensitive, accurate positioning of a pneumatic final control element. A feedback cam in the positioner establishes the actual position of the final control element and can be characterized to provide a square root, square, or a linear relationship to the input signal.

	AV1					
Input Signal						
3-15 psi (std temp range; -40°F to 180°F)	1					
3-27 psi (std temp range; -40°F to 180°F)	2					
⌘ 3-15 psi (extended temp range; -4°F to 250°F)	5					
⌘ 3-27 psi (extended temp range; -4°F to 250°F)	6					
Stroke or Rotary Motion						
0.5 inch (12.7 mm) to 2.0 inch (50.8 mm) or 45 Degrees Rotation	1					
1.0 inch (25.4 mm) to 4.0 inch (101.6 mm) or 90 Degrees Rotation	2					
Manifold / Gage Block						
No Manifold	0					
■ Manifold with Equalizing Valve, Filters & Gage Ports	1					
(req'd for double acting actuators w/manual override)						
Gage Block (gage ports only)	3					
Position Transmitter						
No Position Transmitter	0					
Potentiometric Resistive Transmitter	1					
4-20 mA Output	2					
● Drive Shaft						
Standard with Drive Arm (for Linear Actuators)	0					
0.500 inch Square End (most common for 90° Actuators)	1					
0.342 inch Square End (older DeZurik/K&M Actuators)	2					
0.250 inch Flats (UP1/UP2 after 8/95)	3					
0.375 inch Square End (for DeZurik PowerRac Actuators)	4					
0.156 inch (4 mm) Flats (for Namur Rotary Mounting)	5					
Other Options						
No Options	0					
NEMA 4X Enclosure Rating (must be installed per dwg 258567)	N					
Performance Series (High Pneumatic Gain)	P					

Instruction Manual: I-P88-21C
 (One copy is supplied, at no cost, with order)

- ⌘ Not available with manifold or position transmitter
 - This optional manifold is recommended on all ABB type AC and UP drives.
 - Other drive shafts available upon request. Consult factory for availability.
- Warranty on the AV Positioner is one (1) year.
 Split Range Signal - can be field calibrated for 100% stroke for 50% signal span or 50% stroke for 100% signal span.

AV2

The Type AV2 Electropneumatic Positioner receives a 4-20 mA input from a controller and converts the signal via an ABB I/P Converter to a pneumatic output that positions a power actuator. The AV2 can be adjusted by the user to automatically default to a full open or closed position in case of input signal loss.

	AV2						
Intrinsically Safe/Explosion-proof Design							
Intrinsically Safe Design (Most Common)	3						
❖ Explosion-Proof Design	7						
Stroke or Rotary Motion							
4-20 mA Input; 0.5 inch (12.7 mm) to 2.0 inch (50.8 mm) or 45 Degrees Rotation	1						
4-20 mA Input; 1.0 inch (25.4 mm) to 4.0 inch (101.6 mm) or 90 Degrees Rotation	2						
Manifold/Gage Block							
No Manifold	0						
■ Manifold with Equalizing Valve, Filters & Gage Ports	1						
(req'd for double acting actuators w/manual override)							
Gage Block (gage ports only)	3						
Position Transmitter							
No Position Transmitter	0						
Potentiometric Resistive Transmitter	1						
4-20 mA Output	2						
● Drive Shaft							
Standard with Drive Arm (for linear actuators)	0						
0.500 inch Square End (most common for 90° Actuators)	1						
0.342 inch Square End (older DeZurik/K&M Actuators)	2						
0.250 inch Flats (UP1/UP2 after 8/95)	3						
0.375 inch Square End (for DeZurik PowerRac Actuators)	4						
0.156 inch (4 mm) Flats (for Namur Rotary Mounting)	5						
Other Options							
No Options	0						
NEMA 4X Enclosure Rating (must be installed per dwg 258567)	N						
Performance Series (High Pneumatic Gain)	P						

Instruction Manual: I-P88-21C
 (One copy is supplied, at no cost, with order)

- This optional manifold is recommended on all ABB type AC and UP drives.
- Other drive shafts available upon request. Consult factory for availability.
- ❖ AV27 not available with Manifold, Gage Block, Position Transmitter, or NEMA 4X Enclosure.

AV3

The Type AV3 Electropneumatic Positioner serves special Process Control System needs with its precise, integral electronic I/P signal converter. The AV3 accepts a 4-20 mA signal and will remain in place upon loss of the input signal. This strategy is ideal for flow applications such as with fuel, cooling water and fan dampers where interruptions are unacceptable.

		AV3
Stroke or Rotary Motion		
4-20 mA Input; 0.5 inch (12.7 mm) to		
2.0 inch (50.8 mm) or 45 Degrees Rotation	1	
4-20 mA Input; 1.0 inch (25.4 mm) to		
4.0 inch (101.6 mm) or 90 Degrees Rotation	2	
Manifold/Gage Block		
No Manifold	0	
■ Manifold with Equalizing Valve, Filters & Gage Ports	1	
(req'd for double acting actuators w/manual override)		
Gage Block (gage ports only)	3	
Position Transmitter		
No Position Transmitter	0	
Potentiometric Resistive Transmitter	1	
4-20 mA Output	2	
Drive Shaft		
Standard with Drive Arm (for linear actuators) incl UP3/4/5/6	0	
0.500 inch Square End (most common for 90° Actuators)	1	
0.342 inch Square End (older DeZurik/K&M Actuators)	2	
0.250 inch Flats (UP1/UP2 after 8/95)	3	
0.375 inch Square End (for DeZurik PowerRac Actuators)	4	
0.156 Inch (4 mm) Flats (for Namur Rotary Mounting)	5	
Other Options		
No Options	0	
NEMA 4X Enclosure Rating (must be installed per dwg 258567)	N	
Performance Series (High Pneumatic Gain)	P	

Instruction Manual: *(One copy is supplied, at no cost, with order)*

- AV1/2 PN25039
- AV3 PN25058

- This optional manifold is recommended on all ABB type AC and UP drives.
- Other drive shafts available upon request. Consult factory for availability.

Warranty on the AV Positioner is one (1) year.

ACCESSORIES

Mounting Kits, for diaphragm actuators with yoke mounting bosses (includes mounting bracket, linkage and hardware)	
For stem size 0.375 to 0.75 inch (9.53 - 19.1 mm), adjustable stud length 2.687 inch (68.2 mm)	5327321_12
For stem size 0.75 to 1.0 inch (19.2 - 25.4 mm), adjustable stud length 3.437 inch (87.3 mm)	5327321_13
For stem size 0.375 to 1.0 inch (9.53 - 25.4 mm), adjustable stud length 3.406 inch (86.5 mm) - Fisher	5327321_14
Mounting Bracket, for reciprocating valves (contained in above kits)	5400266_1
Connecting Link, adjustable length 12 inch (304.8 mm) contained in above kits	5312449_4
Mounting Kits, for retrofitting UP Drives from AP to AV Positioners	
For UP10, UP20	5400309_1
For UP30, UP40	258493_1
For UP50, UP60	258494_1
Mounting Kits, for retrofitting AC Drives from old Bailey-Fischer & Porter Part Number Positioners to AV Positioners	
For AC0404	258527_1
For AC0608	258528_1
For AC0816	258530_1
For AC1016	258530_1
Mounting Kits, for retrofitting AC drives from AP to AV Positioners	
For AC0404	258527_1
For AC0608	258528_1
For AC0816	258529_1
For AC1016	258530_2
Mounting Kits, for adding a Beacon™ Indicator or a limit switch package, onto the cover of an AV Positioner	
For adding a Beacon™ Indicator (includes a Westlock black & yellow Indicator)	258570_1
For adding Limit Switches, Westlock 2004 or Equivalent (does not include Limit Switch Package)	258570_2
For adding Limit Switches, Westlock 2007 or Equivalent (does not include Limit Switch Package) (For more information see drawing 258570B)	258570_4
Speed Control Orifices, used when more than one final control element is being operated from the same control signal. Designed to equalize speeds between units.	
0.040 inch (1.016 mm)	5327327_1
Blank (drilled as required)	5327327_2

Pressure Gages, for Calibration

Instrument - 0-30 psig range	5326605_4
Supply - 0-160 psig range	5326605_5
Output - 0-160 psig	5326605_6

Note: The optional manifold/gage block provides gage ports - one for instrument (internal input signal) and two output gages. A supply gage can be installed in the supply line (piping by customer).

External By Pass Valve for Single Acting Diaphragm Applications only

Permits transfer of pneumatic control signal directly to diaphragm so that final control element can be operated while the positioner is being serviced. Use with AV1 __ 1 __ only. 5326945_1

Supply Air Coalescing Filter (Parker No. 11F16EC)

Maximum inlet pressure - 250 psi, 1/4 -18 NPT 5328563_2

Supply Air Regulator (Parker No. 06R118AC)

Maximum inlet pressure - 250 psi, 1/4 -18 NPT 1951029_5

SPARE PARTS/PARTS KITS: (AV1 thru AV4 except as noted)

Diaphragm Parts

Diaphragm Assembly Kit (3-15 psig and 3-27 psig)	258486_1
3-15 psig Positioner, Diaphragm cover	5400295_1
3-27 psig Positioner (AV1 only), Diaphragm Cover	5400295_2

Note: When converting a 3-15 Positioner to a 3-27 Input Positioner, or vice versa, both the Diaphragm Assembly Kit and the appropriate Diaphragm Cover are required.

Manifold Parts

Manifold Kit for field addition	258491_1
Filter Replacement Kit	258487_1
Shut Off Valve Kit	258270_1

Explosion-Proof Positioner Parts (AV27)

Kit to Mount Explosion-proof I/P Converter to Pneumatic Positioner (does not include I/P)	258612_1
IP Converter for AV27 (for replacement or to make an AV27 in field, requires above kit)	1949547_2

Gage Block Kit for Field Addition

258569_1

I/P Converter Replacement Kit (for AV23 only)

258651_1

Characterizing Cams

Forward-acting full rise cam, 90 degree rotation	5400281_1
Reverse-acting full rise cam, 90 degree rotation	5400281_2
Forward-acting half rise cam, 45 degree rotation	5400289_1
Reverse-acting half rise cam, 45 degree rotation	5400289_2
Blank Cam, for custom shaping	5400277_1

Pilot Valve Assembly Kit

Pilot Valve Assembly Kit (Performance Series , AV _____ P)	258488_3
Pilot Valve Assembly Kit (High Temp. Model, AV15/6)	258488_2
Pilot Valve Assembly Kit (High Temp. & Performance Series Model, AV1 5/6 _____ P)	258488_4

Feedback Arm

Feedback arm for linkage attachment, for 90 degree cam rotation	5327445_1
Feedback arm for linkage attachment, for 45 degree cam rotation	5327445_2

Cover Assembly (includes cover, window, gasket and plastic cover inserts)

258545_1

Cam Follower Arm Assembly

258544_1

Position Transmitter - Field Addition Kits

Pneumatic Position Transmitter	258492_1
--------------------------------	----------

Cam Shaft

1/2 inch Square End Connection	5400278_1
Tapered End Connection for Linear Feedback Arm	5400287_1
0.342 inch Square End for Older DeZurik/K&M Actuators	5400287_2
0.250 inch Flats (UP1 / UP2 after 8/95)	5400287_3
■ 0.375 inch Square End (For DeZurik PowerRac Actuators)	5400287_4
■ 0.156 inch (4 mm) Flats (For Namur Rotary Mounting)	5400287_5
■ Also requires conversion plate	5400321_1

ABB has Sales & Customer Support expertise in over 100 countries worldwide

www.abb.com

The Company's policy is one of continuous product improvement and the right is reserved to modify the information contained herein without notice.

Printed in USA (7.22.05)

© 2005 ABB Inc.



ABB Inc.
 125 East County Line Road
 Warminster
 PA 18974
 USA
 Tel: +1 215 674 6000
 Fax: +1 215 674 7183

ABB Ltd
 Howard Road, St. Neots
 Cambridgeshire
 PE19 8EU
 UK
 Tel: +44 (0)1480 475321
 Fax: +44 (0)1480 217948