



Pressure Transmitters with NEMA 4X integral junction box
Type F-10 Standard Industrial **Type F-11** Flush Diaphragm
Type IF-10 Intrinsically Safe **Type IF-11** Flush Diaphragm
 Intrinsically Safe

Tronic

(Previous model numbers 891.X3.900, 891.X3.920, 892.X3.900, 892.X3.920)

- NEMA 4X for washdown and corrosion resistance
- Designed for extremely harsh industrial environments
- 4-20 mA 2-wire output signal, others available
- IF-10 and IF-11 are FM and Ex approved for Class 1 Division 1 locations when used with an approved barrier
- Can be assembled to chemical seals



The 900 Series NEMA 4X pressure transmitters are designed for extremely harsh industrial pressure measurement applications. Each unit undergoes extensive testing and calibration to achieve an accuracy of 0.25% full scale. State-of-the-art surface mount technology ensures that the unit is protected against vibration, shock and humidity. Each unit is temperature compensated to assure accuracy and long term stability under severe ambient temperature variations.

The compact design features an integral NEMA 4X junction box for washdown, corrosion resistance, and protection against electromagnetic interference. The Type F-10 features a 1/2" NPT male process connection suitable for many industrial pressure measurement applications. The flush diaphragm Type F-11 is designed to measure highly viscous fluids, sludge, or media containing solids. The Types IF-10 and IF-11 intrinsically safe transmitters are engineered for applications requiring Class 1, Division 1 protection in hazardous environments. All models may be equipped with either direct or remote mount diaphragm seals for corrosive or high temperature applications.



STANDARD RANGES

RANGE	MAXIMUM*	BURST**	RANGE	MAXIMUM*	BURST**
30"-0 HgVac	70 PSI	70 PSI	0-250 PSI(A)	1100 PSI	1100 PSI
30"-0-30 PSI	250 PSI	250 PSI	0-300 PSI	1100 PSI	1100 PSI
30"-0-60 PSI	500 PSI	500 PSI	0-400 PSI	1100 PSI	3600 PSI
30"-0-100 PSI	500 PSI	500 PSI	0-500 PSI(A)	1100 PSI	5800 PSI
30"-0-160 PSI	500 PSI	500 PSI	0-600 PSI	1100 PSI	5800 PSI
30"-0-200 PSI	1100 PSI	1100 PSI	0-750 PSI	1100 PSI	5800 PSI
0-50 INWC	30 PSI	30 PSI	0-1000 PSI	1750 PSI	8000 PSI
0-100 INWC	30 PSI	30 PSI	0-1500 PSI	2900 PSI	11,600 PSI
0-5 PSI	30 PSI	30 PSI	0-2000 PSI	4600 PSI	14,500 PSI
0-10 PSI	60 PSI	60 PSI	0-3000 PSI	4600 PSI	14,500 PSI
0-15 PSI(A)	70 PSI	70 PSI	0-5000 PSI	11,600 PSI	25,000 PSI
0-25 PSI(A)	145 PSI	145 PSI	0-8000 PSI	17,400 PSI	35,000 PSI
0-30 PSI	145 PSI	145 PSI	0-10,000 PSI	17,400 PSI	35,000 PSI
0-50 PSI(A)	250 PSI	250 PSI	0-15,000 PSI	21,750 PSI	43,500 PSI
0-60 PSI	250 PSI	250 PSI	0-25,000 PSI	29,400 PSI	58,800 PSI
0-100 PSI(A)	500 PSI	500 PSI	0-40,000 PSI	44,100 PSI	73,500 PSI
0-160 PSI	500 PSI	500 PSI	0-60,000 PSI	65,000 PSI	102,900 PSI
0-200 PSI	500 PSI	500 PSI			

Notes:

* Maximum pressure, causing no permanent changes in specifications but may lead to adjustable zero and span shifts.

** Burst pressure, leading to destruction of transmitter.

(A) Standard ranges available with absolute pressure reference.

Type F-11 and IF-11 flush diaphragm available up to 8000 PSI. Ranges \geq 25,000 PSI are equipped with a F-250-C 9/16-18 high pressure tube connection.

Type F-10 and F-11

Type IF-10 and IF-11 Intrinsically Safe

Input 11-30 VDC (14-30 VDC for 0-10V output signal)	
Output & load limitations 4-20mA 2-wire $R_{(max)} = (V_s - 11V)/0.02 A$ 0-5 V 3-wire $R_{(min)} \geq 5 k \text{ Ohm}$ 0-10 V 3-wire $R_{(min)} \geq 10 k \text{ Ohm}$	
Test signal 4-20mA 2-wire $R_{(max)} = 15 \text{ ohms}$ (Available with 4-20mA output only)	

Input 11-28 VDC	
Output & load limitations 4-20mA 2-wire $R_{(max)} = (V_s - 11V)/0.02 A$	
Test signal 4-20mA 2-wire $R_{(max)} = 15 \text{ ohms}$	

Accuracy	
Linearity (B.F.S.L.)	$\leq 0.25\%$ of span {0.125%}
Hysteresis	$\leq 0.1\%$ of span
Repeatability	$\leq 0.05\%$ of span
1 yr. stability	$\leq 0.2\%$ of span
Response time	$\leq 1 \text{ ms}$
(10-90% full scale)	
Zero & span adjustment	Approximately $\pm 10.0\%$ full scale

Accuracy	
Linearity (B.F.S.L.)	$\leq 0.25\%$ of span {0.125%}
Hysteresis	$\leq 0.1\%$ of span
Repeatability	$\leq 0.05\%$ of span
1 yr. stability	$\leq 0.2\%$ of span
Response time	$\leq 1 \text{ ms}$
(10-90% full scale)	
Zero & span adjustment	Approximately $\pm 10.0\%$ full scale

Temperature	
Temperature compensated	+32 °F to 176 °F
Media	-22 °F to 212 °F
Optionally	{-40 °F to 282 °F}
Ambient	-4 °F to 176 °F
Storage	-40 °F to 212 °F
Temperature error (reference temperature 70 °F)	
On zero (% of span/18 °F)	≤ 0.2 (≤ 0.4 for ranges < 100" WC)
On span (% of span/18 °F)	≤ 0.2

Temperature	
Temperature compensated	+32 °F to 175 °F
Media	-25 °F to 212 °F
Ambient	-5 °F to 175 °F
Storage	-40 °F to 212 °F
Temperature error (reference temperature 70 °F)	
On zero (% of span/18 °F)	< 0.2 (≤ 0.4 for ranges < 100 INWC)
On span (% of span/18 °F)	< 0.2

Process connection		
F - 10	50 INWC to 15,000 PSI	1/2" NPT Male {others available}
	$\geq 25,000 \text{ PSI}$	F-250-C Female
F - 11	50 INWC to 30 PSI	G1B Flush
	50 PSI to 8,000 PSI	G1/2B Flush
Electrical connection		
1/2" NPT female conduit (IP 67 / NEMA 4X washdown and corrosion resistant)		
PG 13.5 mm Cord Grip (IP 67 / NEMA 4X washdown and corrosion resistant)		

Process connection		
IF - 10	50 INWC to 15,000 PSI	1/2" NPT Male {others available}
	$\geq 25,000 \text{ PSI}$	F-250-C Female
IF - 11	50 INWC to 30 PSI	G1B Flush
	50 PSI to 8,000 PSI	G1/2B Flush
Electrical connection		
1/2" NPT female conduit (IP 67 / NEMA 4X washdown and corrosion resistant)		
PG 13.5 mm Cord Grip (IP 67 / NEMA 4X washdown and corrosion resistant)		

Material	
Wetted parts	316 stainless steel Hastelloy C4 flush diaphragm Teflon PFA coated flush diaphragm
Body material	304 stainless steel
Conduit housing	Epoxy coated aluminum { 304 stainless steel }
Transmitting liquid	
Silicone oil for F-11 all ranges, and F-10 to 300 PSI {Halocarbon oil for oxygen service} {Vegetable oil for food service}	

Material	
Wetted parts	316 stainless steel Hastelloy C4 flush diaphragm Teflon PFA coated flush diaphragm
Body material	304 stainless steel
Conduit housing	Epoxy coated aluminum
Transmitting liquid	
Silicone oil for IF-11 all ranges, and IF-10 to 300 PSI {Halocarbon oil for oxygen service} {vegetable oil for food service}	

Electrical protection	
Protected against reverse polarity, short circuit output and suppressor diode for high-voltage protection. EMI protected per IEC 801.	
Vibration protection	
Internal electronics 100% potted in epoxy casting resin	
Weight approx. 1.1 lbs	

Electrical protection	
Protected against reverse polarity, short circuit output and suppressor diode for high-voltage protection. EMI protected per IEC 801.	
Vibration protection	
Internal electronics 100% potted in epoxy casting resin	
Weight approx. 1.3 lbs	

Notes: Items in curved brackets { } are available on special order.

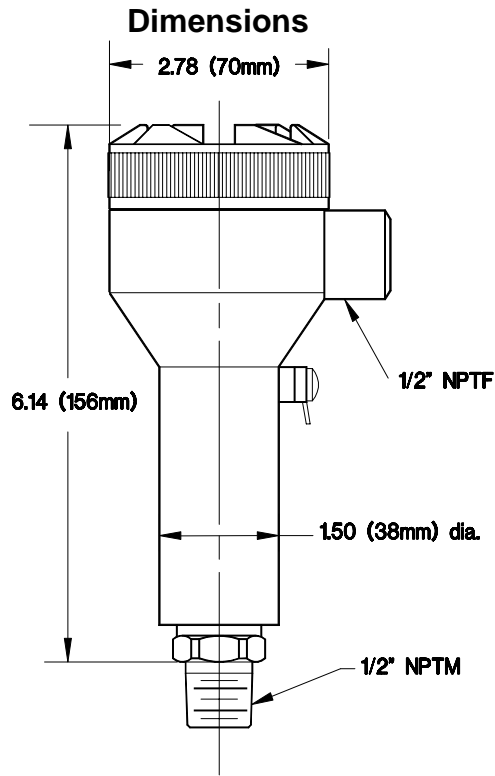

Flush process connections: F-11 and IF-11

for ranges ≤ 30 PSI

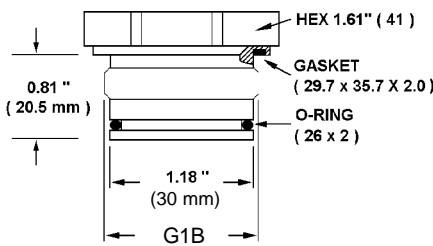

for ranges
50 PSI to 8000 PSI

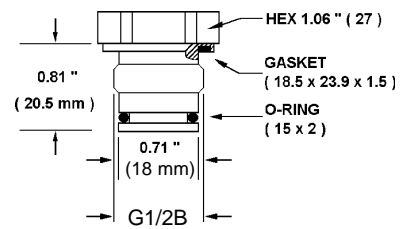

Matching P-1 weld insert adapters

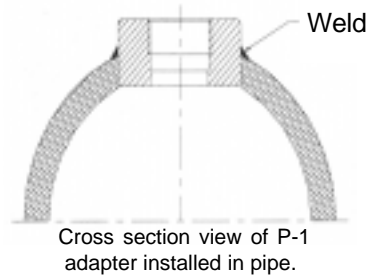
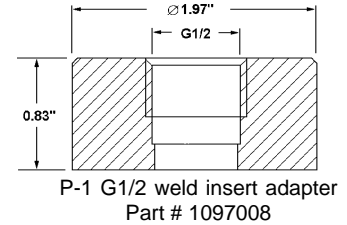
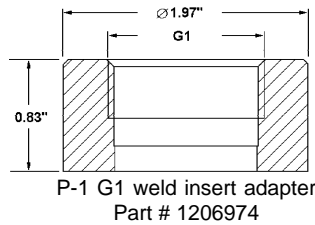

Type IF-10 and IF-11 (892.X3.9X0) Intrinsically Safe

Approval Authority	CENELEC / BASEEFA		Factory Mutual
Codes of Compliance	EN 50014/50020 relating to intrinsically safe products		FM-3610 intrinsic standard
Conformity Specifications	E Ex ia II C T5	E Ex ia II C T6	Intrinsically Safe per entity requirements for Class I, II, & III, Division 1, Groups A,B,C,D,E,F, & G. Nonincendive for Class I, Division 1, Groups A,B,C, & D. Hazardous indoor and outdoor NEMA 4 locations.
Power Supply	11..28 VDC	11..28 VDC	
Short Circuit Rating	660 mA	660 mA	V max = 28 V
Power Rating	(1.75 W)	(1.75 W)	I max = 660 mA
Operating Temperature	-5/+150°F (-5/+165°F)	-5/+150°F (-5/+140°F)	Ci = 20 nF, Li = 0 uH

Note: Power supply may be by means of common zener barrier or equivalent certified devices if the transmitters are operated within above temperature limits. The temperatures in parentheses are applicable if the output of the power supply is limited to the power rating values given in parentheses.

Wiring

2-wire system

Wire	Coding	Terminal
Supply +	U_B+ / $S+$	1
Signal -	$0V$ / $S-$	2

Note: Type IF-10 and IF-11 must be used with an intrinsically safe barrier or intrinsically safe power supply when installed in hazardous locations.

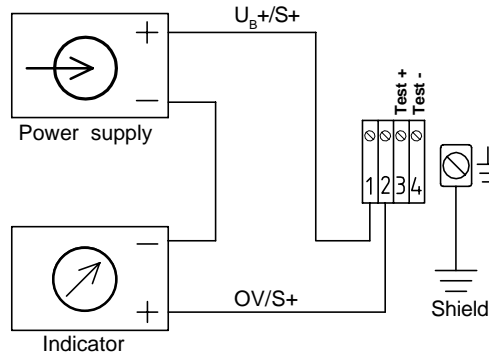

3-wire system

Wire	Coding	Terminal
Supply +	U_B+	1
Supply - Signal -	$0V$ / $S-$	3
Signal +	$S+$	2

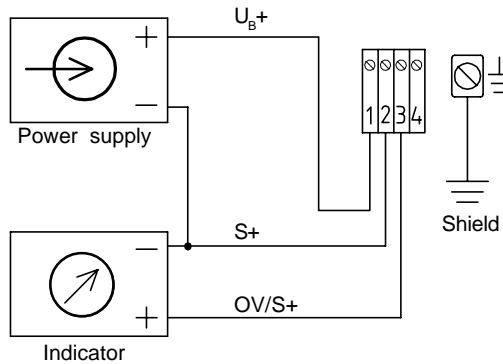

Calibration

Remove the junction box cover. (Note: be sure to follow intrinsically safe requirements when calibrating intrinsically safe transmitters.) Attach a meter and power supply to the electrical connector. For gauge ranges the zero potentiometer can be adjusted to produce a null output when no pressure is applied. Span adjustment requires the use of a reference pressure source. Compound and absolute ranges require a vacuum and pressure source. When calibration is complete, reinstall the junction box cover hand tight.

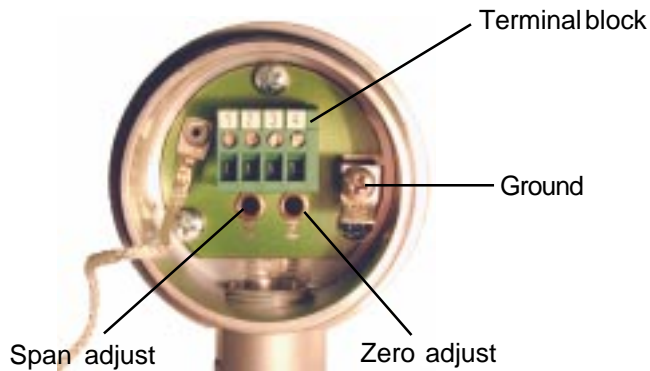

THE MEASURE OF Total Performance™

Ordering Information:

State computer part number (if available) / type number / size / range / connection size and location / options required.

Specifications given in this price list represent the state of engineering at the time of printing. Modifications may take place and the specified materials may change without prior notice.



WIKAI Instrument Corporation

1000 Wiegand Boulevard

Lawrenceville, Georgia 30043-5868

Tel: 770-513-8200 Fax: 770-338-5118

http://www.wika.com e-mail: info@wika.com