

Inert, Instrument Class Valve

2-Way, Normally Closed Solenoid Operated Valve
Model: SV27

INTRODUCTION

With the SV27, Valcor Scientific introduces the first complete line of inert, solenoid operated, valves designed specifically to the exacting requirements of the scientific instrument industry.

The SV27 instrument valves accept the challenges of critical flow and pressure requirements while conserving valuable power and “drawer space”.

Applications cover a broad spectrum of instruments including: Clinical Chemistry, Analytical Chemistry, Environmental Sampling, and Drug Discovery.

DESCRIPTION

The SV27 Two-Way, normally closed, solenoid operated valves offer the instrument designer the broadest range of choices in the industry.

Available as free standing, surface mounted manifold or cartridge mounted manifold, the SV27 is available in an exhaustive list of engineering plastics, as well as a wide choice of elastomers.

As applications become more involved, component reliability becomes critical. Life tested to over 18 million cycles, the SV27 delivers the proven reliability that will minimize costly system failures.



APPLICATIONS

Due to the wide latitude in design choices, the SV27 is well suited to a broad range of applications requiring high performance standards. The SV27 allows standardizing on one core design for an instrument while facilitating custom features when the application demands change. Standardizing on one core design reduces qualification times, as well as total fluid control costs.

The SV27 valves are available as individual components or packaged in sub-systems which are assembled, system tested and delivered complete for system integration. Valcor application engineers and design teams are available to extend customer engineering capabilities, shorten market introduction times, and help reduce overall system costs.

MODEL SV27
2-WAY FREE STANDING VALVE

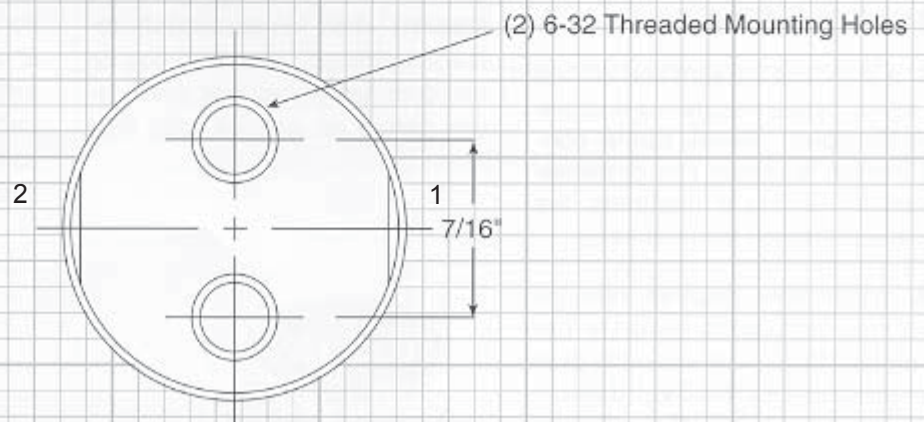
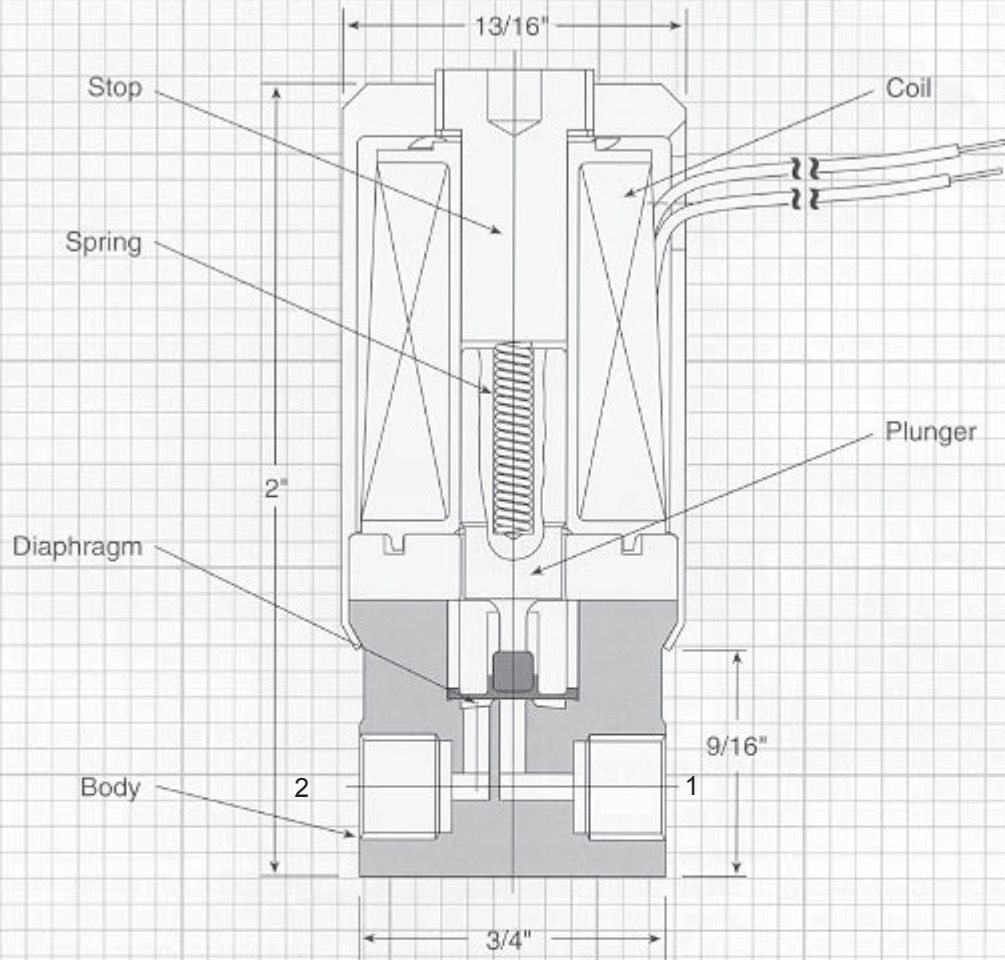

OPTIONAL MOUNTING CONFIGURATIONS - CONSULT FACTORY



Model SV27, 2-Way Surface Mount

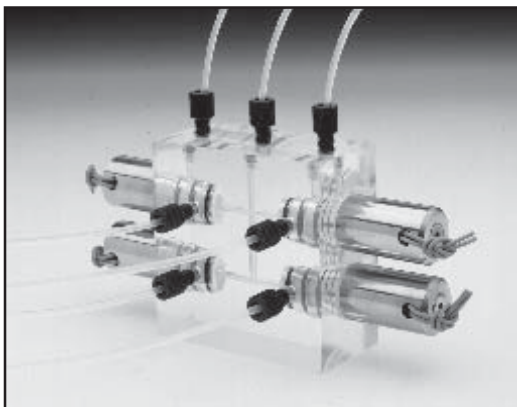

Model SV27, 2-Way Cartridge Mount

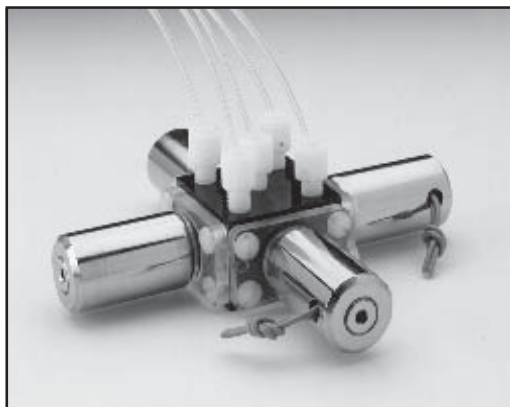

Model SV27, 2-Way Surface Mount

1

Valcor Scientific

Valcor Engineering Corporation®

2 Lawrence Road • Springfield, New Jersey 07081

973-467-8400 • Fax: 973-467-9592

scientific@valcor.com • www.valcor.com

© Copyright 2002 Valcor Engineering Corporation® Printed in USA